

Finite Automata

Part One

Computability Theory

What problems can we solve with a computer?

What **problems** can we solve with a computer?

What is a
“problem?”



Problems with Problems

- Before we can talk about what problems we can solve, we need a formal definition of a “problem.”
- We want a definition that
 - corresponds to the problems we want to solve,
 - captures a large class of problems, and
 - is mathematically simple to reason about.
- No one definition has all three properties.

Formal Language Theory

Strings

- An **alphabet** is a finite, nonempty set of symbols called **characters**.
 - Typically, we use the symbol Σ to refer to an alphabet.
- A **string over an alphabet Σ** is a finite sequence of characters drawn from Σ .
- Example: If $\Sigma = \{\mathbf{a}, \mathbf{b}\}$, here are some valid strings over Σ :
a aabaaabbabaabaaaabbb abbababba
- The **empty string** has no characters and is denoted ϵ .
- Calling attention to an earlier point: since all strings are finite sequences of characters from Σ , you cannot have a string of infinite length.

Languages

- A **formal language** is a set of strings.
- We say that L is a **language over Σ** if it is a set of strings over Σ .
- Example: The language of palindromes over $\Sigma = \{\mathbf{a}, \mathbf{b}, \mathbf{c}\}$ is the set
 - $\{\varepsilon, \mathbf{a}, \mathbf{b}, \mathbf{c}, \mathbf{aa}, \mathbf{bb}, \mathbf{cc}, \mathbf{aaa}, \mathbf{aba}, \mathbf{aca}, \mathbf{bab}, \dots\}$
- The set of all strings composed from letters in Σ is denoted Σ^* .
- Formally, we say that L is a language over Σ if $L \subseteq \Sigma^*$.

How many of the following statements are true?

- ***Alphabets*** are sequences of characters.
- ***Languages*** are sets of strings.
- ***Strings*** are sets of characters.
- ***Characters*** are individual symbols.
- ***Languages*** are sequences of characters.

Answer at [Pollevo.com/cs103](https://www.pollevo.com/cs103) or
text **CS103** to **22333** once to join, then a **number**.

To Recap

- **Languages** are sets of strings.
- **Strings** are sequences of characters.
- **Characters** are individual symbols.
- **Alphabets** are sets of characters.

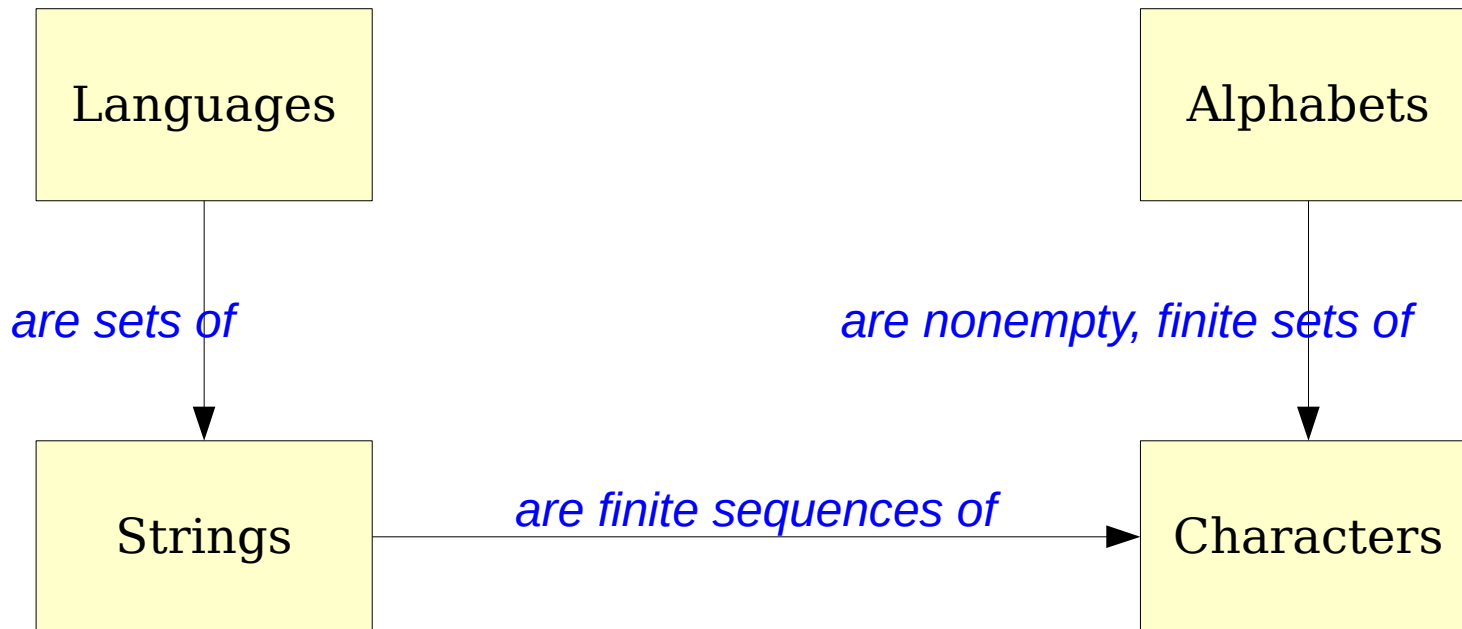

Old MacDonald Had a Symbol,

♪ Σ -eye- ϵ -ey \in , Oh! ♪

- You may have noticed that we have several letter-E-ish symbols in CS103, which can get confusing!
- Here's a quick guide to remembering which is which:
 - In language theory, Σ refers to an ***alphabet***.
 - In language theory, ϵ is the ***empty string***, which is length 0.
 - In set theory, use \in to say “is an ***element of***.”
 - In set theory, use \subseteq to say “is a ***subset of***.”

What problems can we solve with a computer?

What problems can we solve with a computer?

What kind of
computer?

A diagram consisting of a light gray rectangular box highlighting the word 'computer' in the main question. A thin black arrow starts from the top of the blue text 'What kind of computer?' and points upwards to the bottom center of the gray box.

Computers are Messy

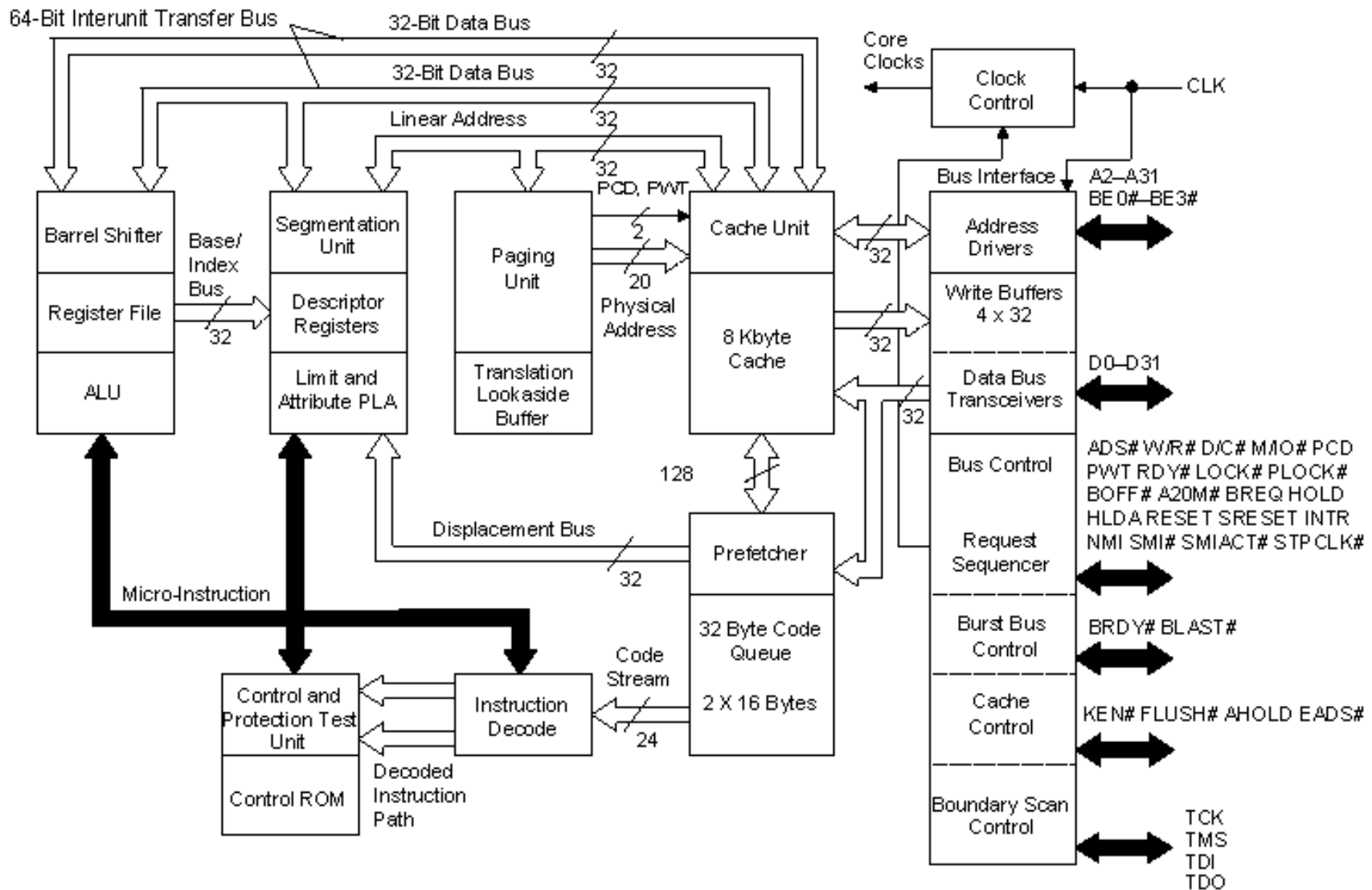

What is a computer?



Bell Labs in Oakland, CA
(Photo by [Larry Luckham](#), 1969)

iWatch
(2018)



Computers are Messy

That messiness makes it hard to *rigorously* say what we *intuitively* know to be true: that, on some fundamental level, different brands of computers or programming languages are more or less equivalent in what they are capable of doing.



vs

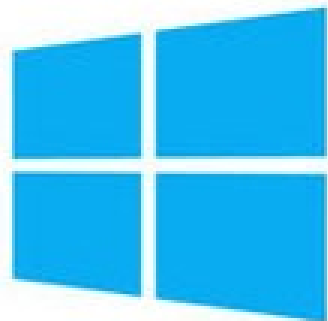

C vs C++

vs Java

vs Python

We need a simpler way of
discussing computing machines.

An ***automaton*** (plural: ***automata***) is a mathematical model of a computing device.

Automata are Clean

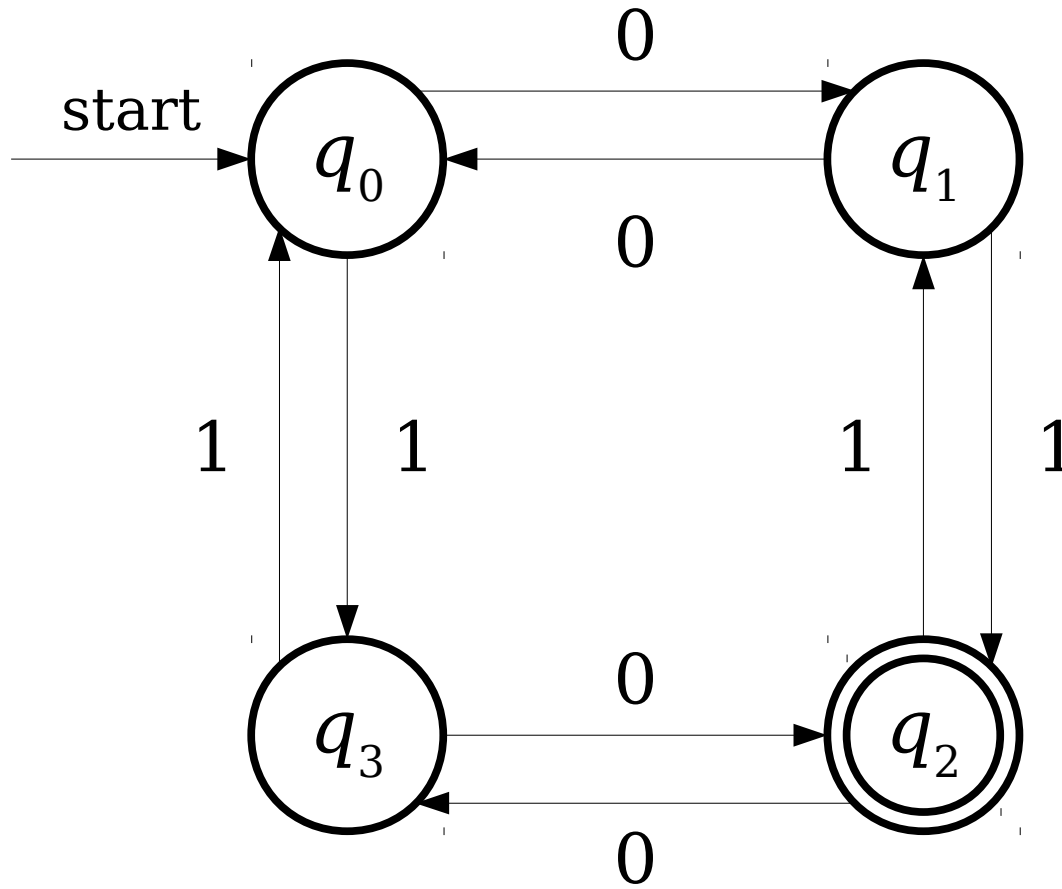

Why Build Models?

- ***Mathematical simplicity.***
 - It is significantly easier to manipulate our abstract models of computers than it is to manipulate actual computers.
- ***Intellectual robustness.***
 - If we pick our models correctly, we can make broadly applicable claims about huge classes of real computers by arguing that they're just special cases of our more general models.

Two Models of a Machine

- The models of computation we will explore in this class correspond to different conceptions of what a computer could do.
- ***Finite automata*** (next two weeks) are an abstraction of computers with finite resource constraints.
 - Provide upper bounds for the computing machines that we can actually build.
- ***Turing machines*** (later) are an abstraction of computers with unbounded resources.
 - Provide upper bounds for what we could ever hope to accomplish.

What problems can we solve with a computer?

Finite Automata

A ***finite automaton*** is a simple type of mathematical machine for determining whether a string is contained within some language.

Each finite automaton consists of a set of *states* connected by *transitions*.

A Simple Finite Automaton

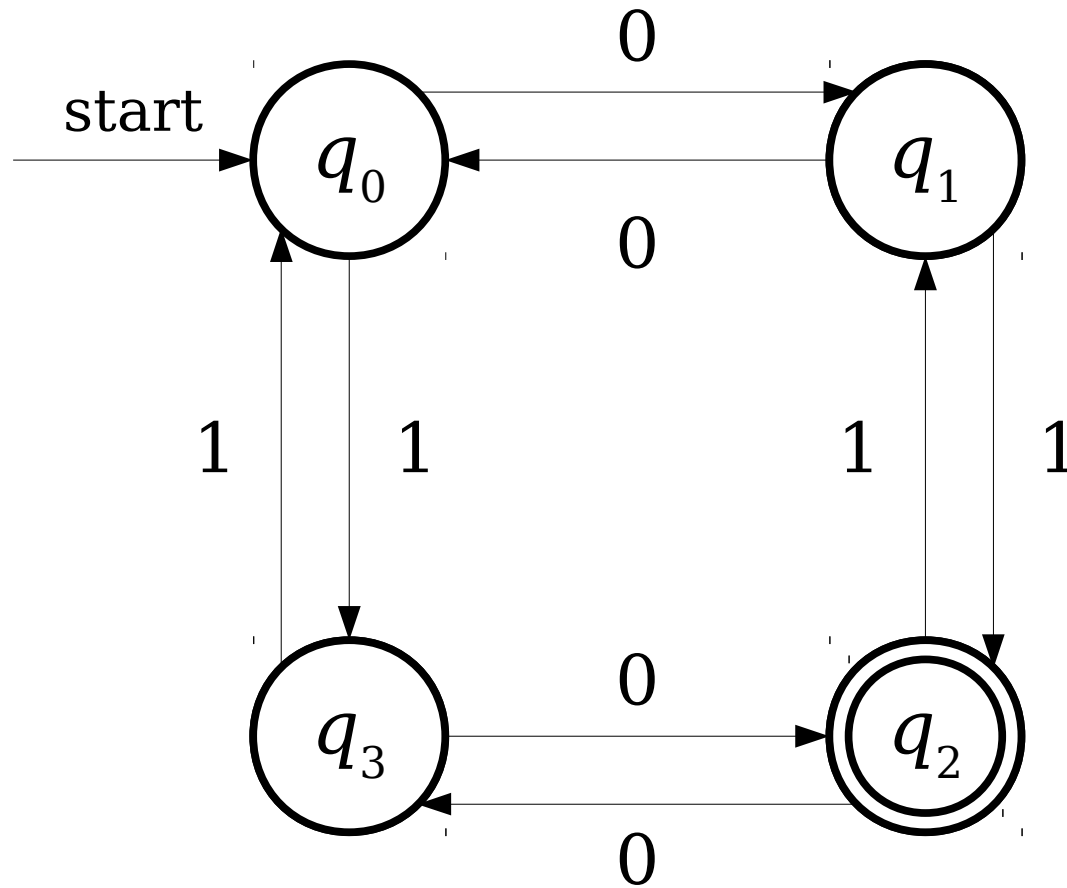

A Simple Finite Automaton

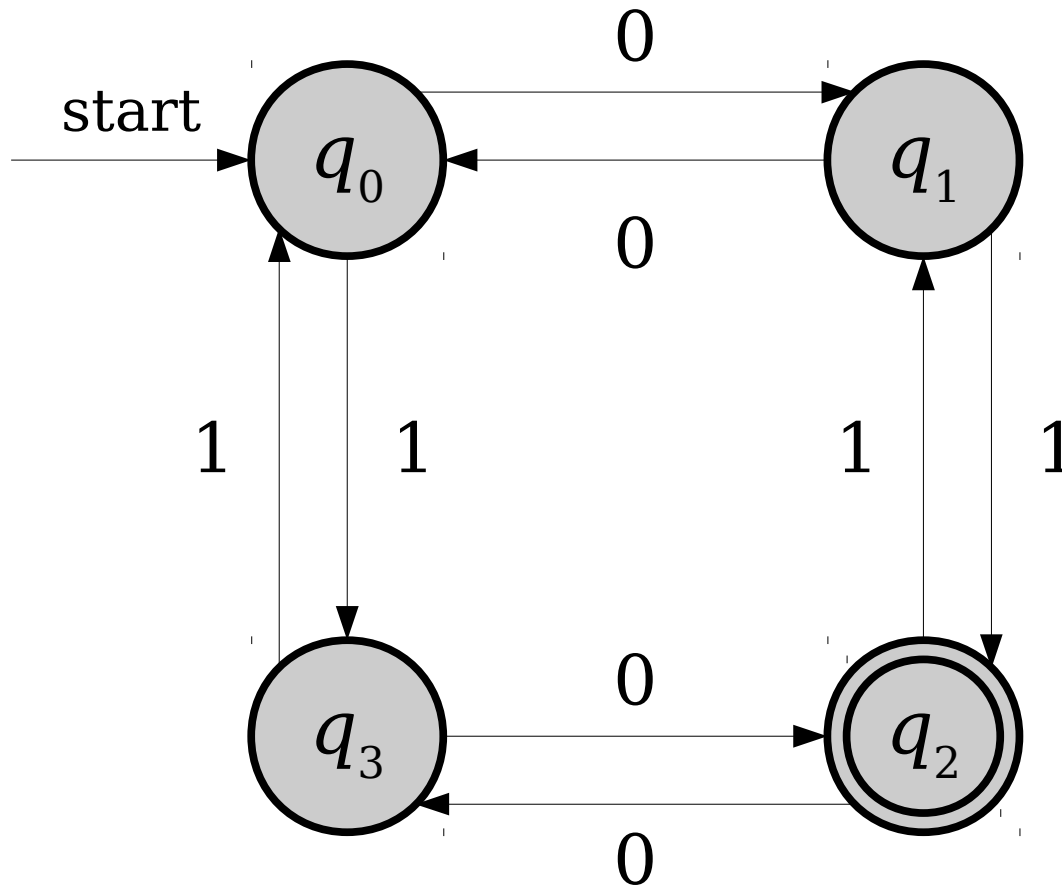

Each circle represents
a **state** of the
automaton.

A Simple Finite Automaton

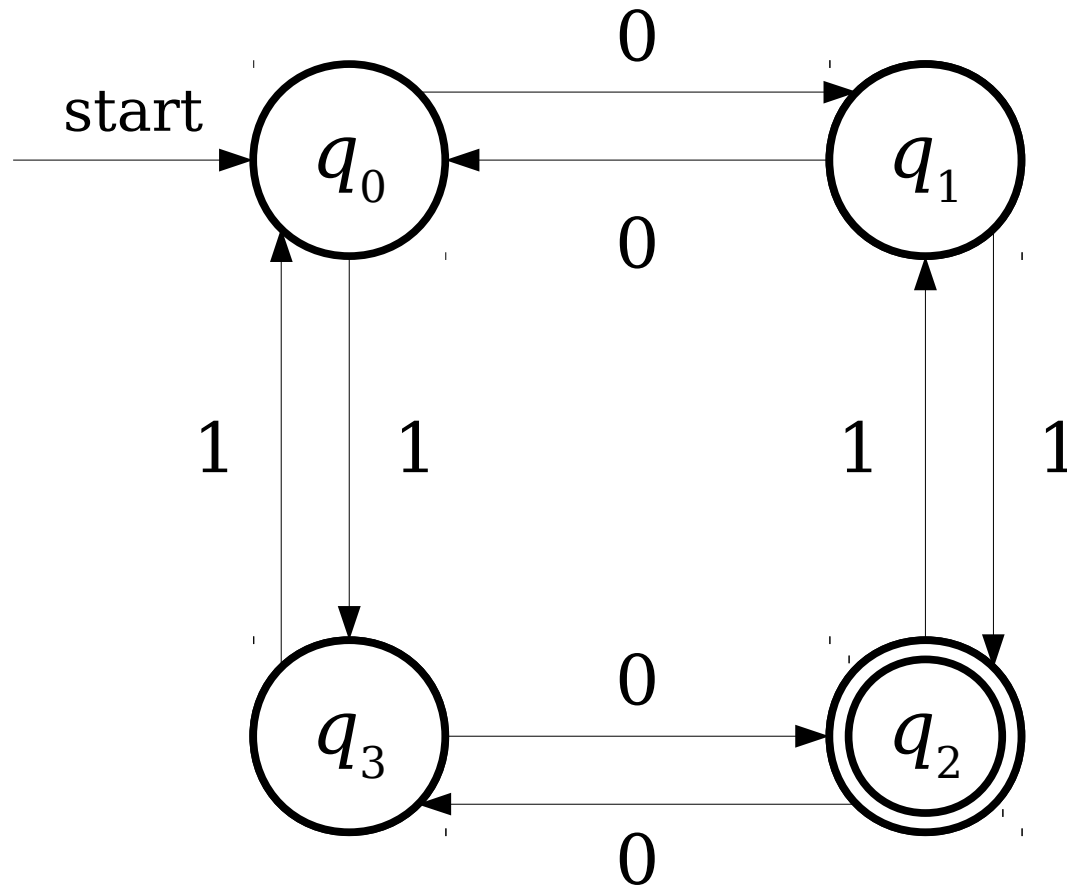

A Simple Finite Automaton

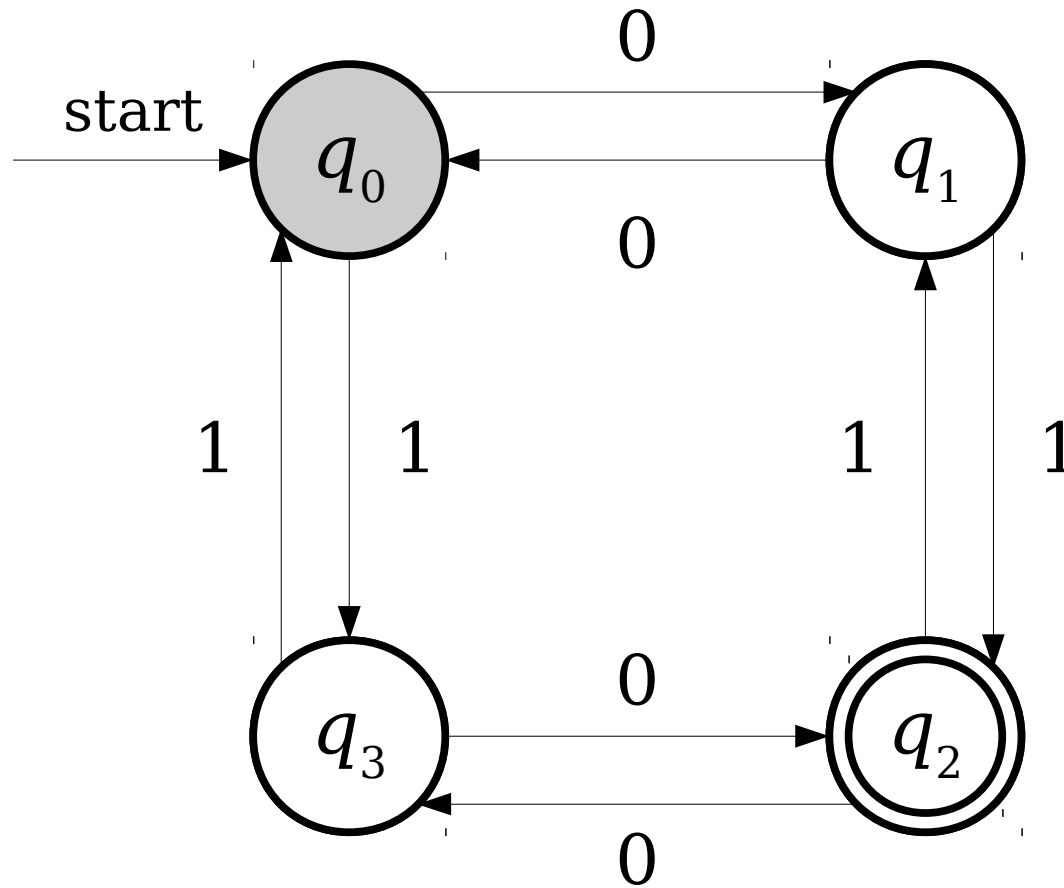

One special state is designated as the **start state**.

A Simple Finite Automaton

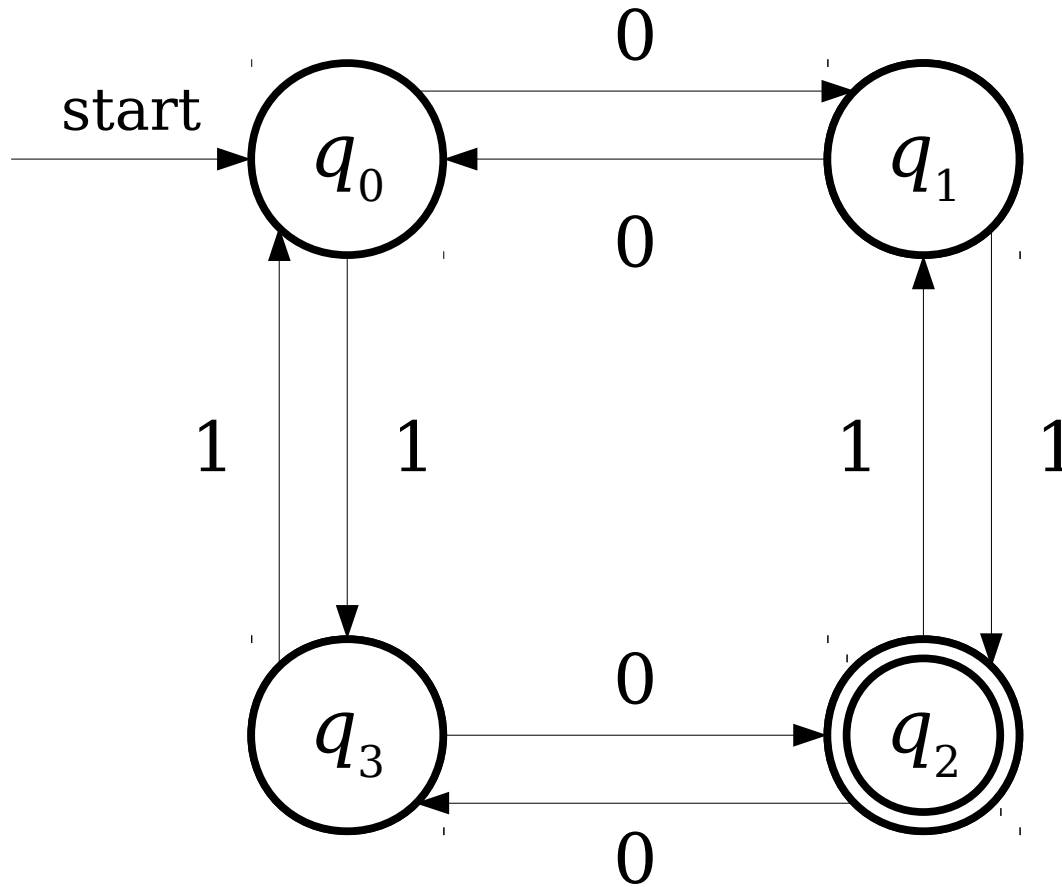

A Simple Finite Automaton

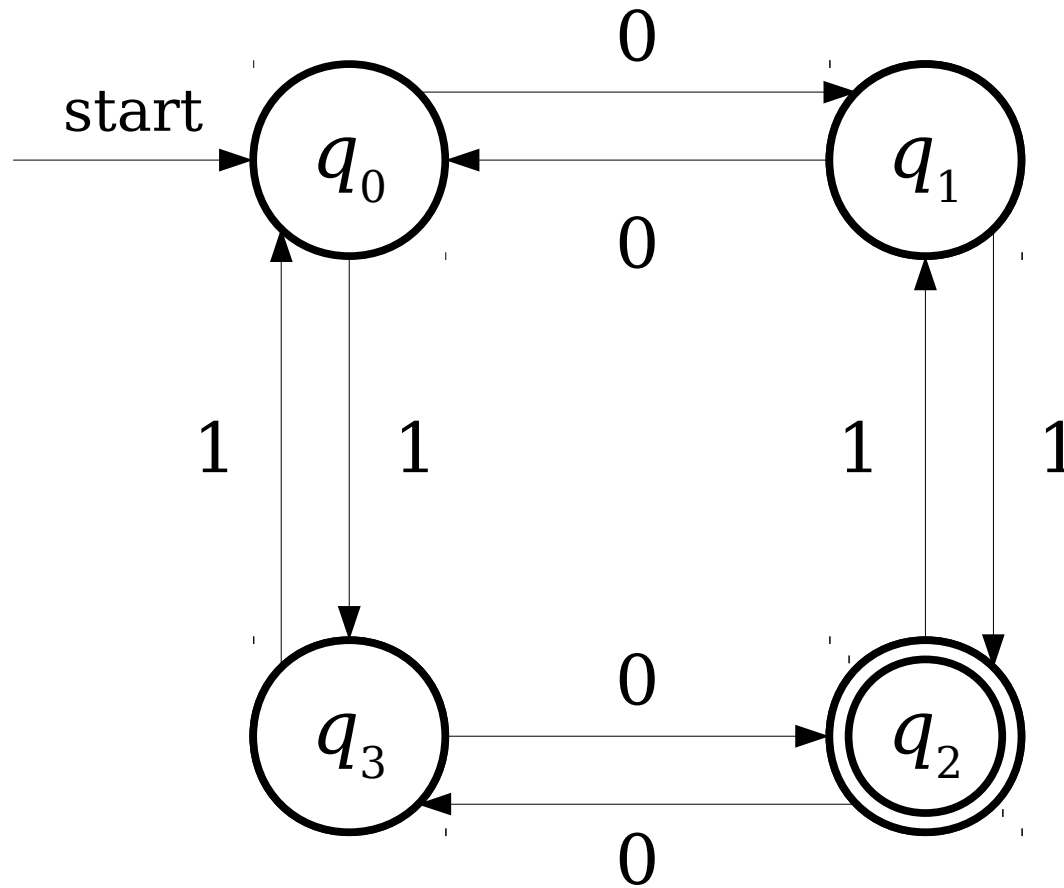

0 1 0 1 1 0

A Simple Finite Automaton

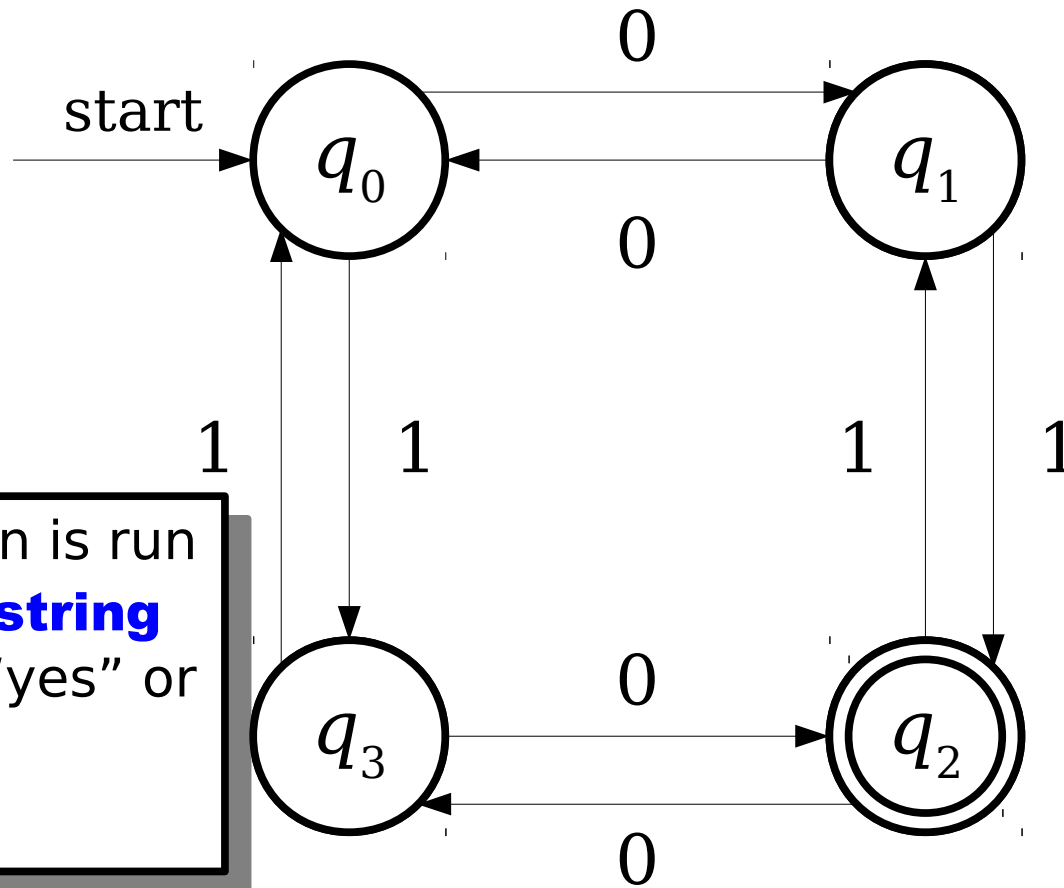

The automaton is run on an **input string** and answers “yes” or “no.”

0 1 0 1 1 0

A Simple Finite Automaton

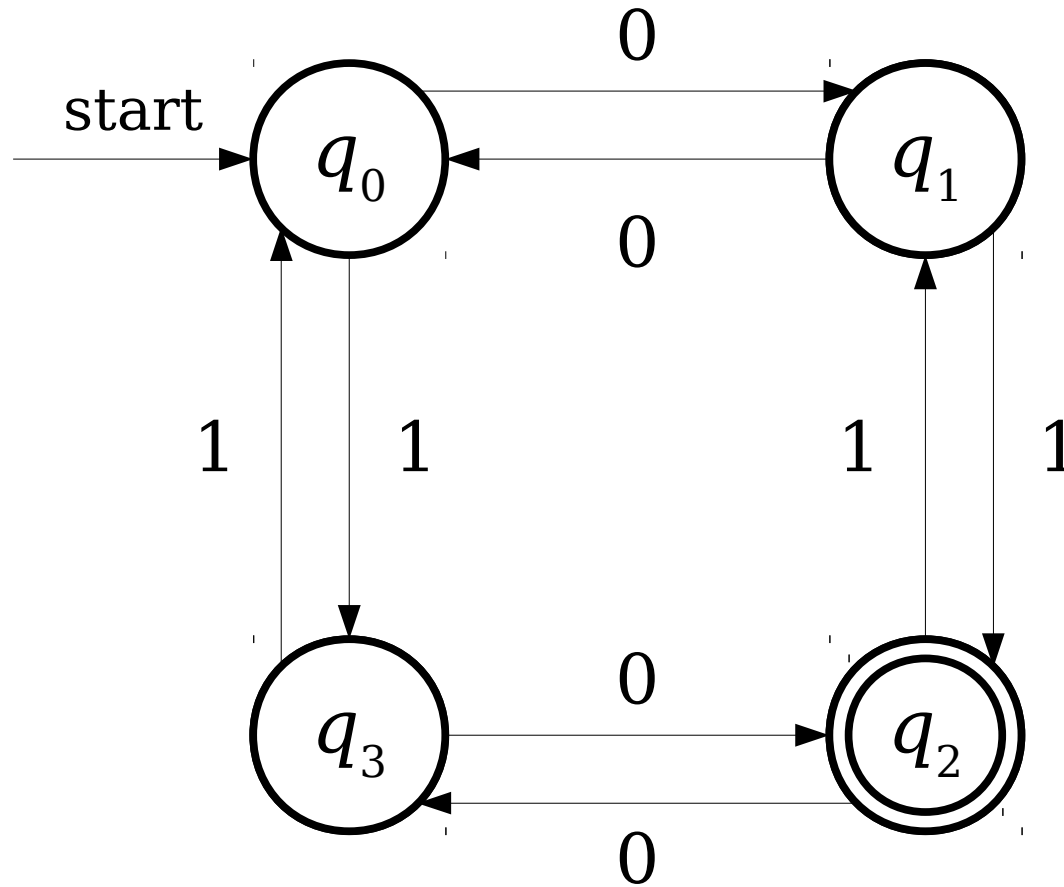

0 1 0 1 1 0

A Simple Finite Automaton

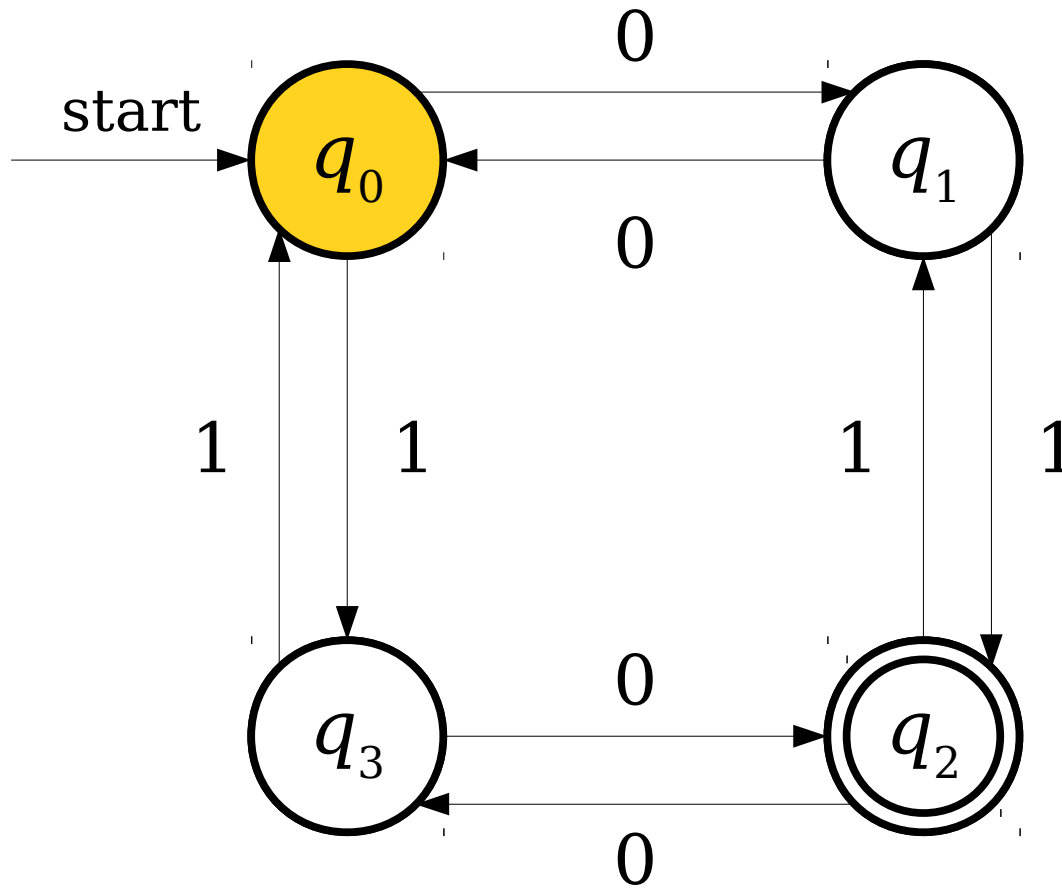

0 1 0 1 1 0

A Simple Finite Automaton

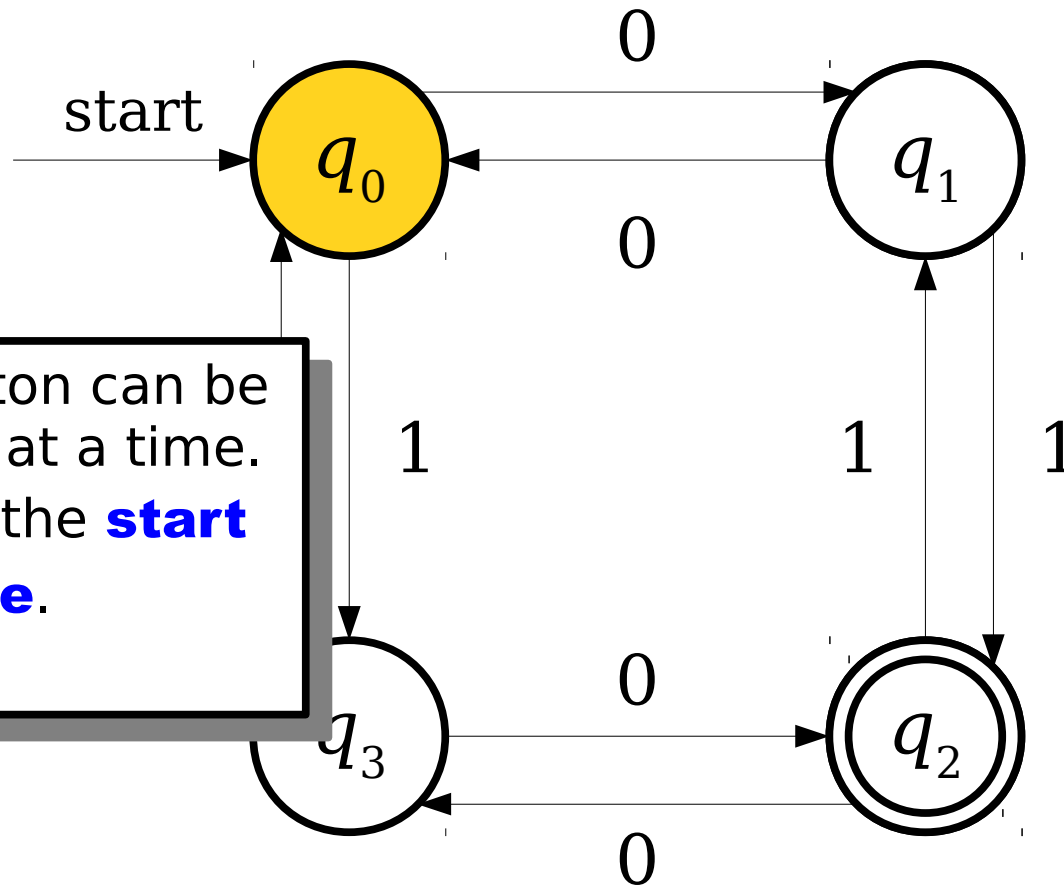

The automaton can be in one state at a time. It begins in the **start state**.

0 1 0 1 1 0

A Simple Finite Automaton

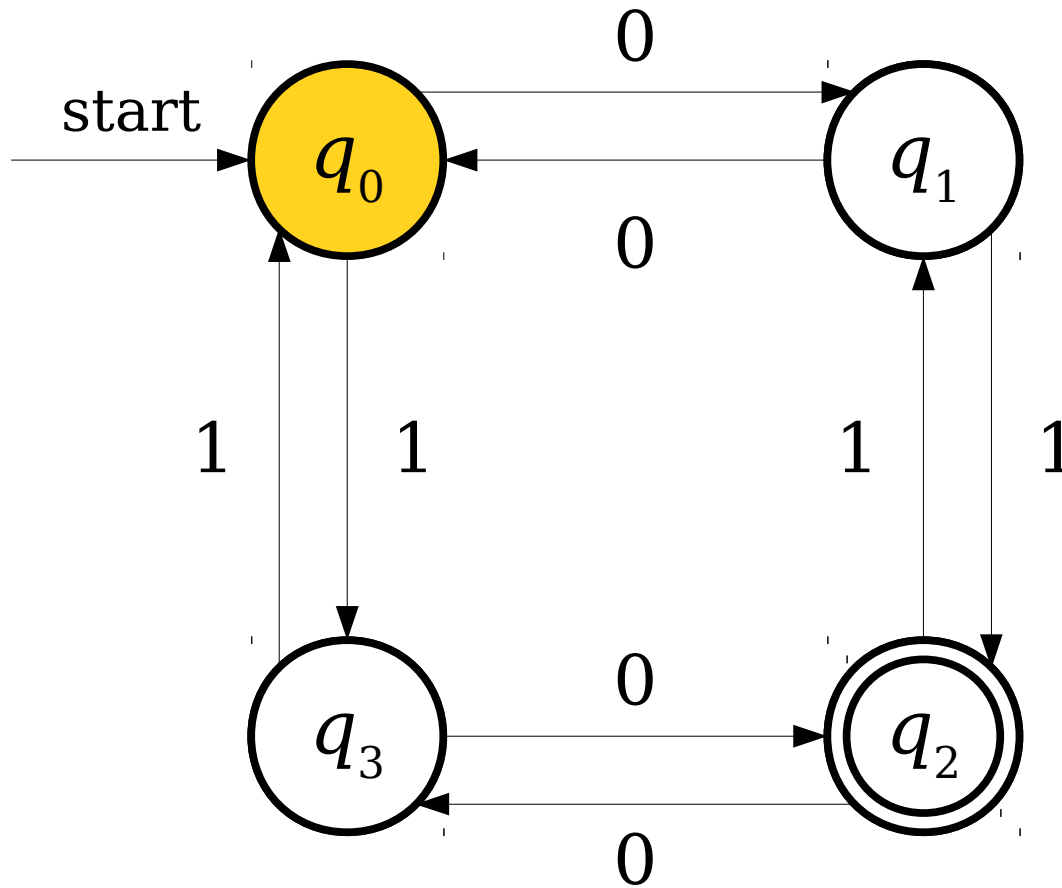

0 1 0 1 1 0

A Simple Finite Automaton

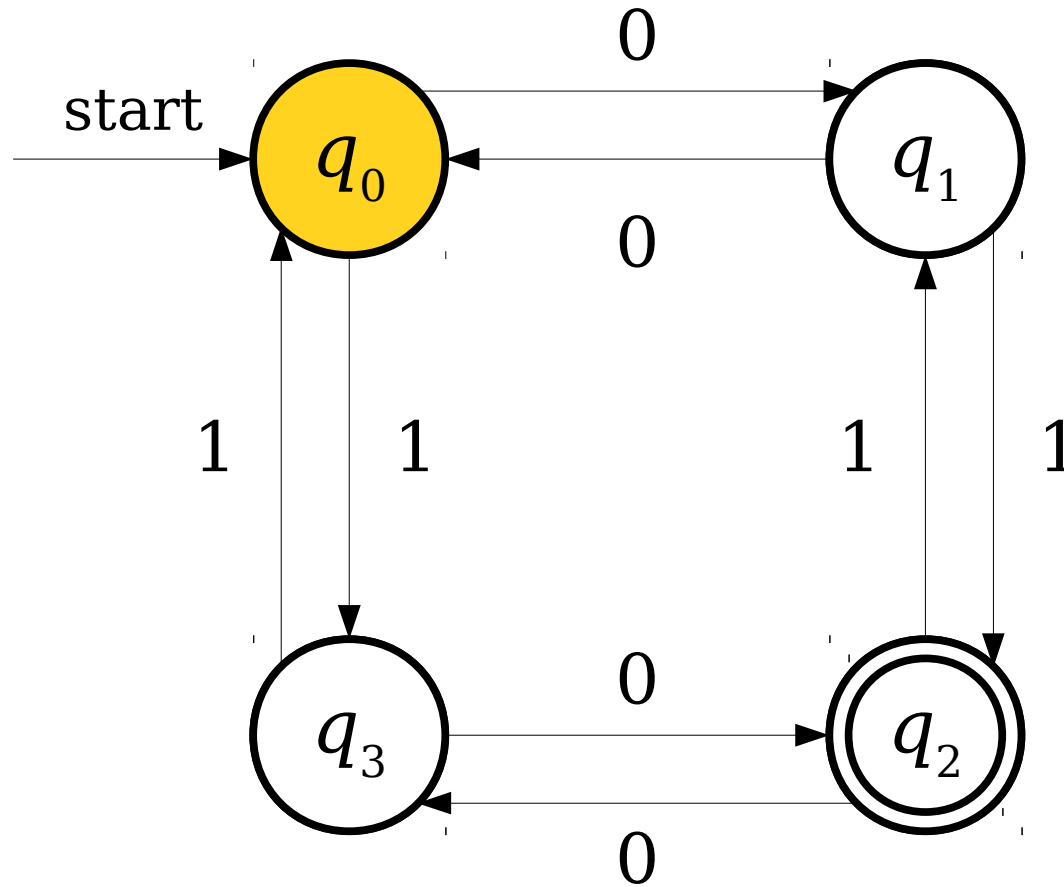

0 1 0 1 1 0

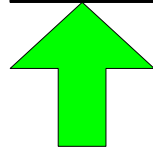

A Simple Finite Automaton

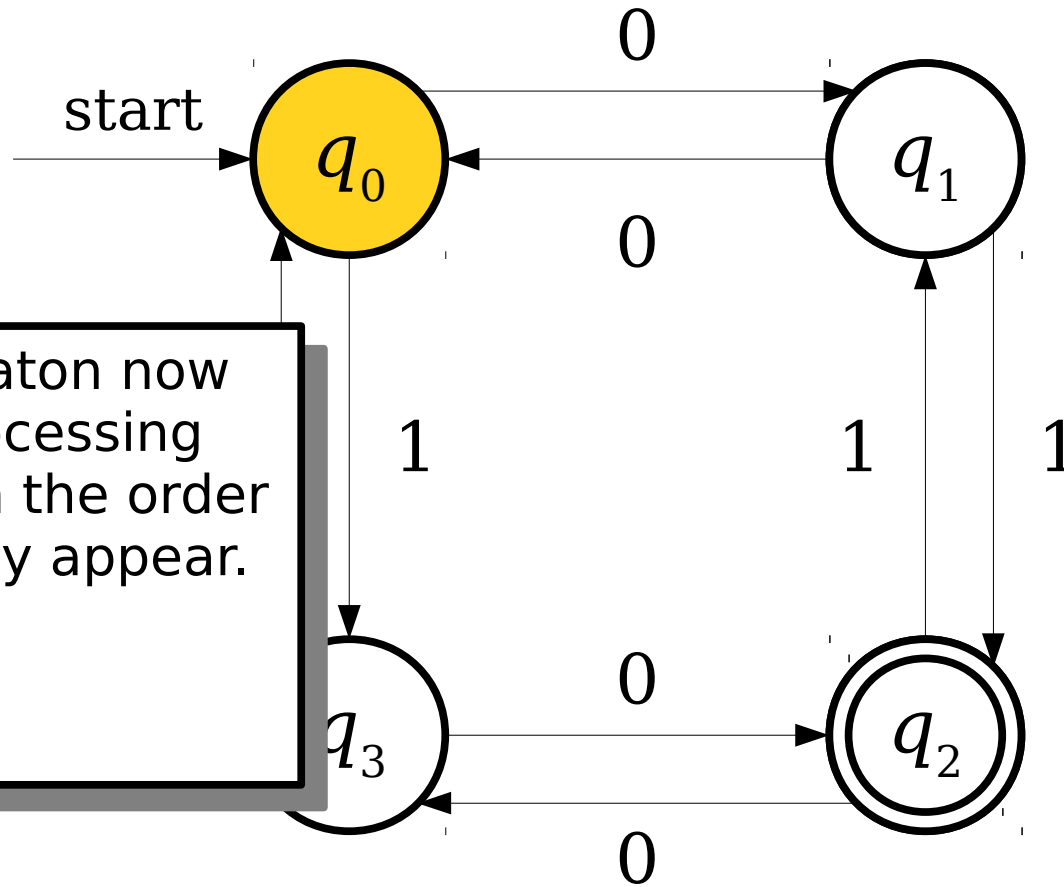

The automaton now begins processing characters in the order in which they appear.

0 1 0 1 1 0

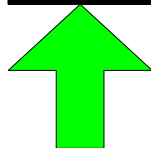

A Simple Finite Automaton

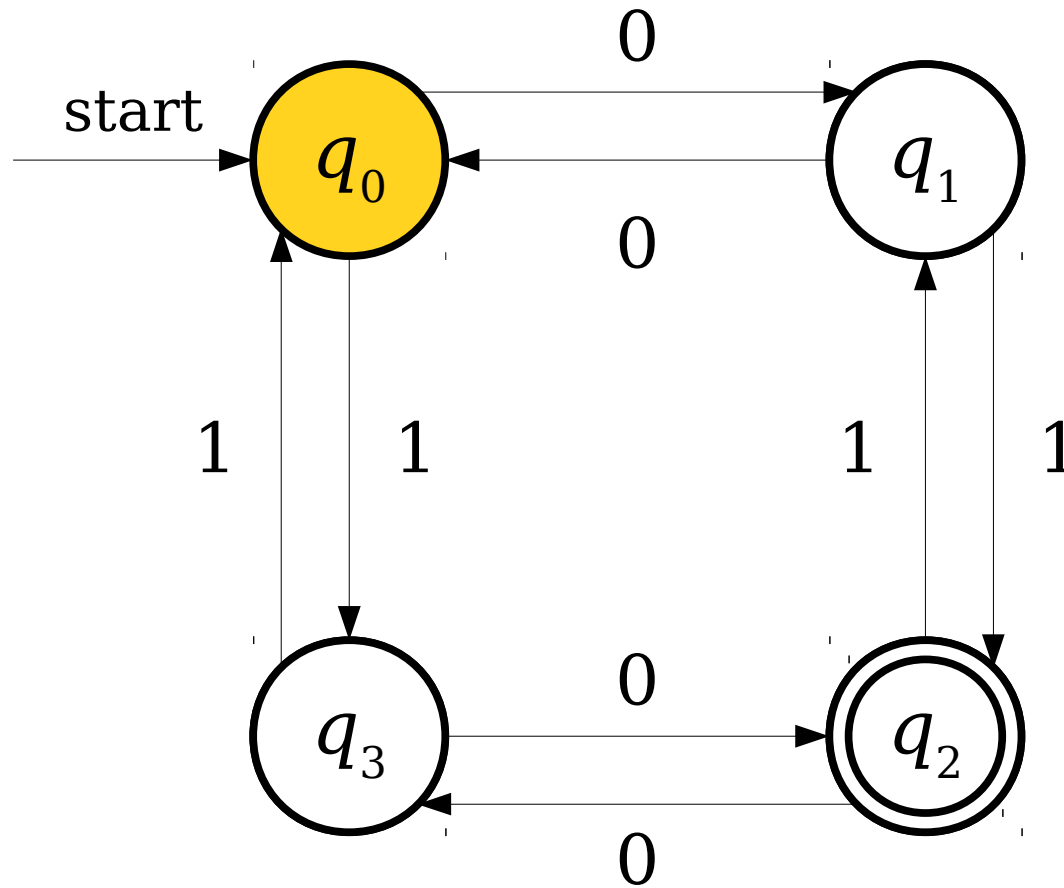

0 1 0 1 1 0

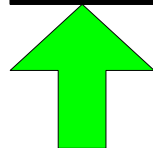

A Simple Finite Automaton

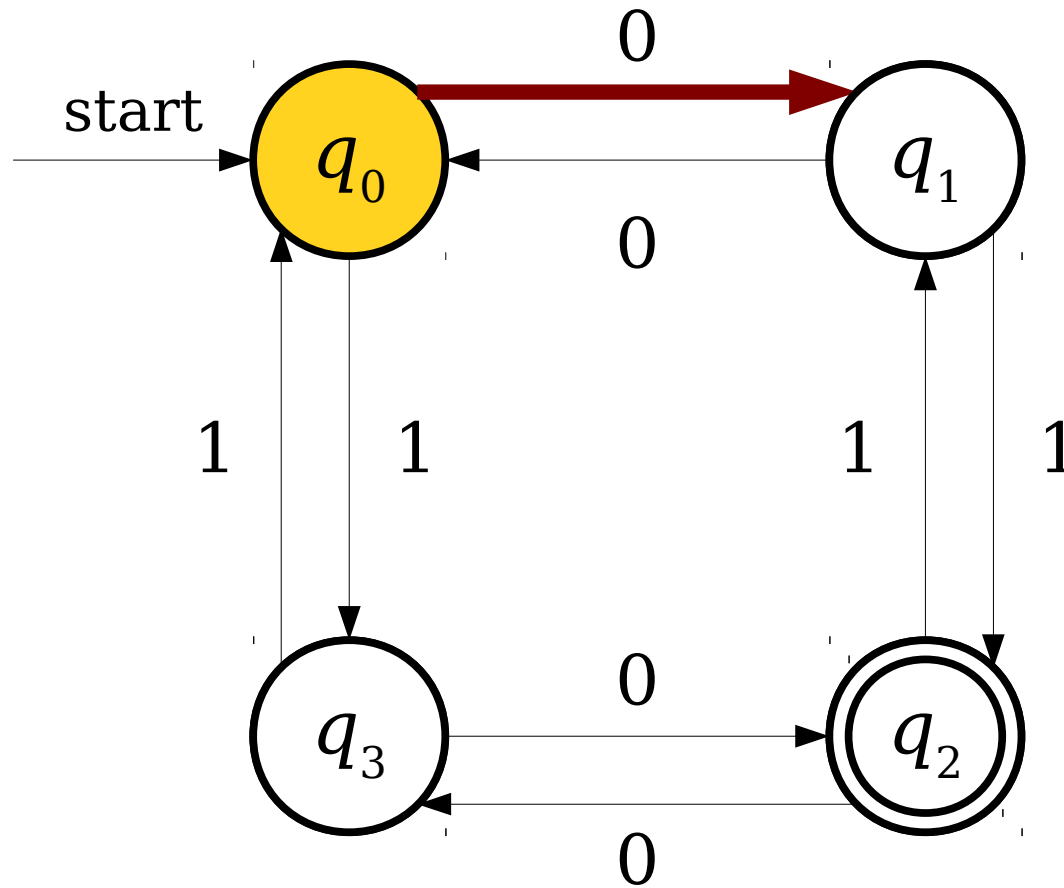

0 1 0 1 1 0

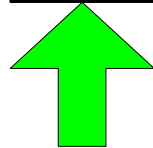

A Simple Finite Automaton

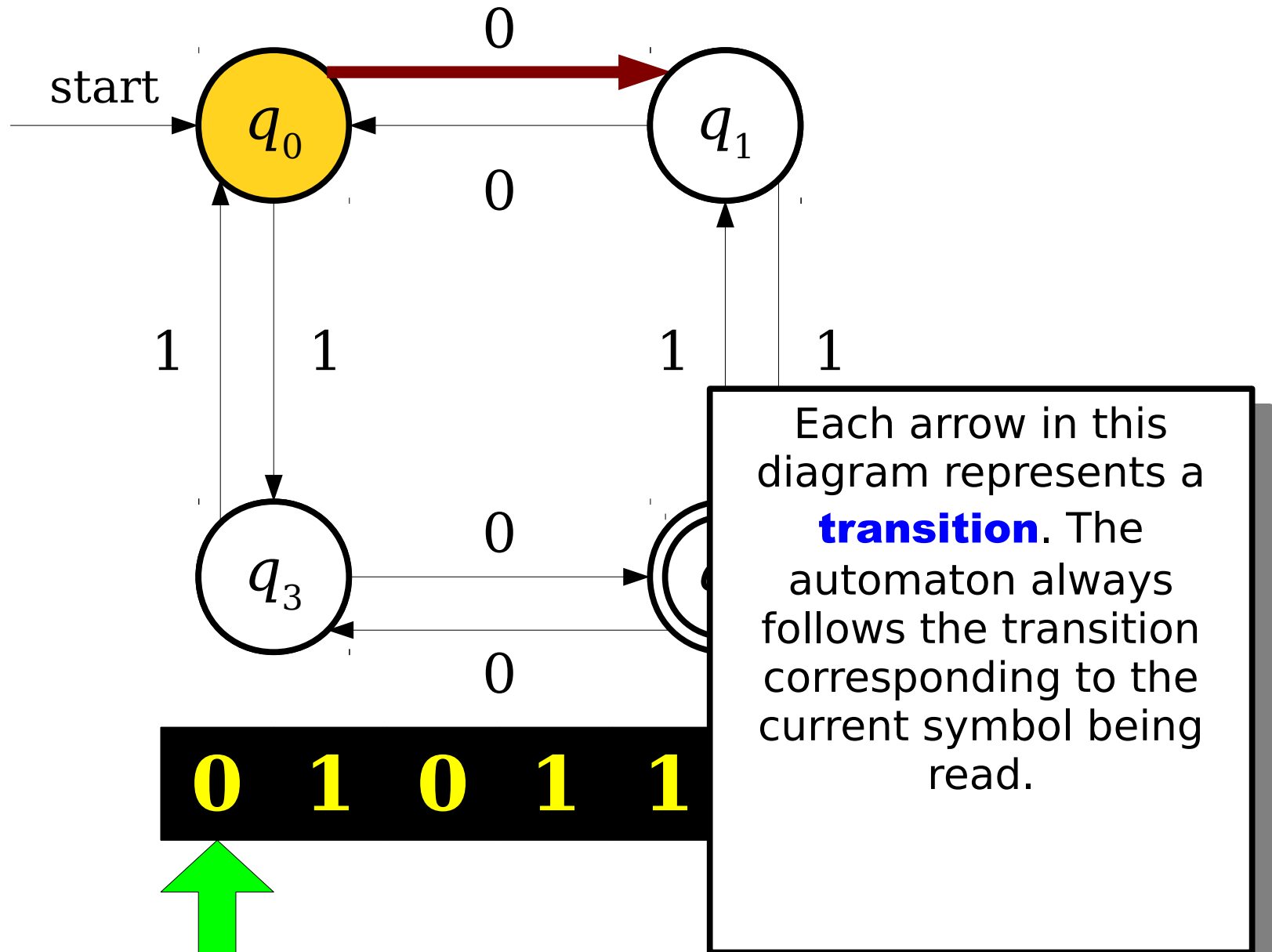

A Simple Finite Automaton

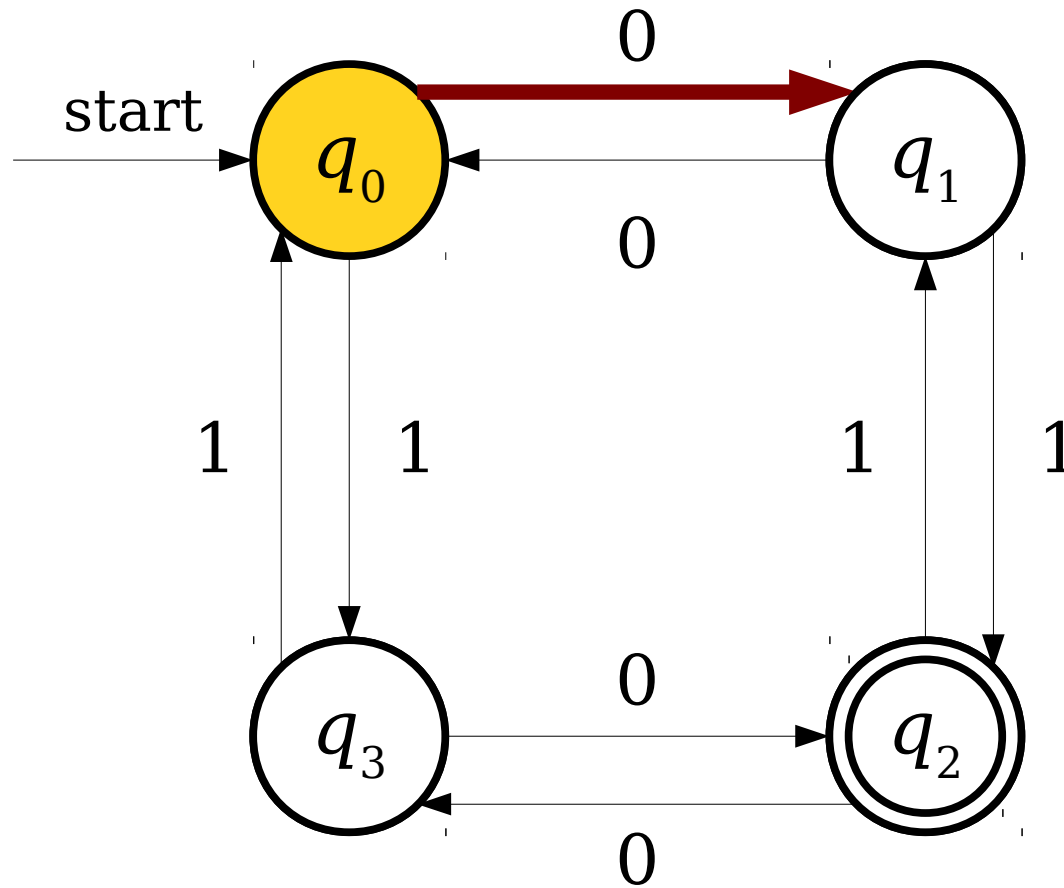

0 1 0 1 1 0

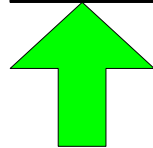

A Simple Finite Automaton

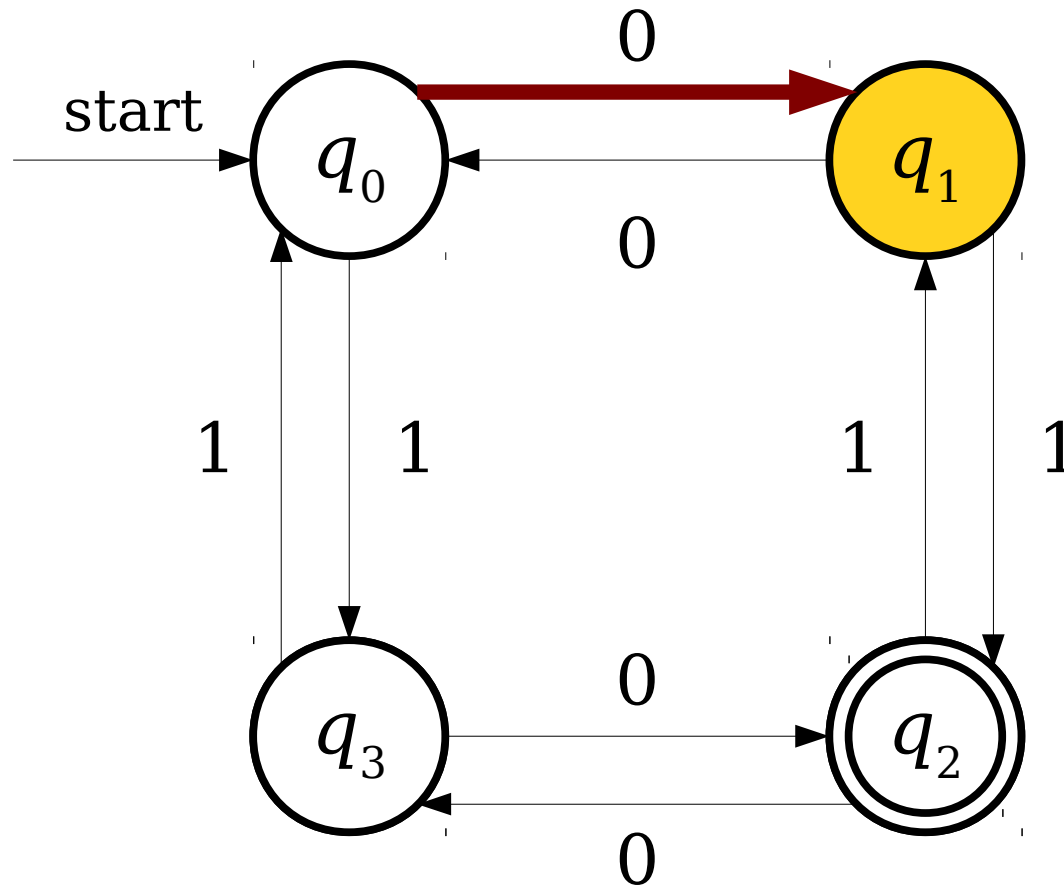

0 1 0 1 1 0

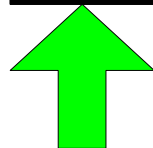

A Simple Finite Automaton

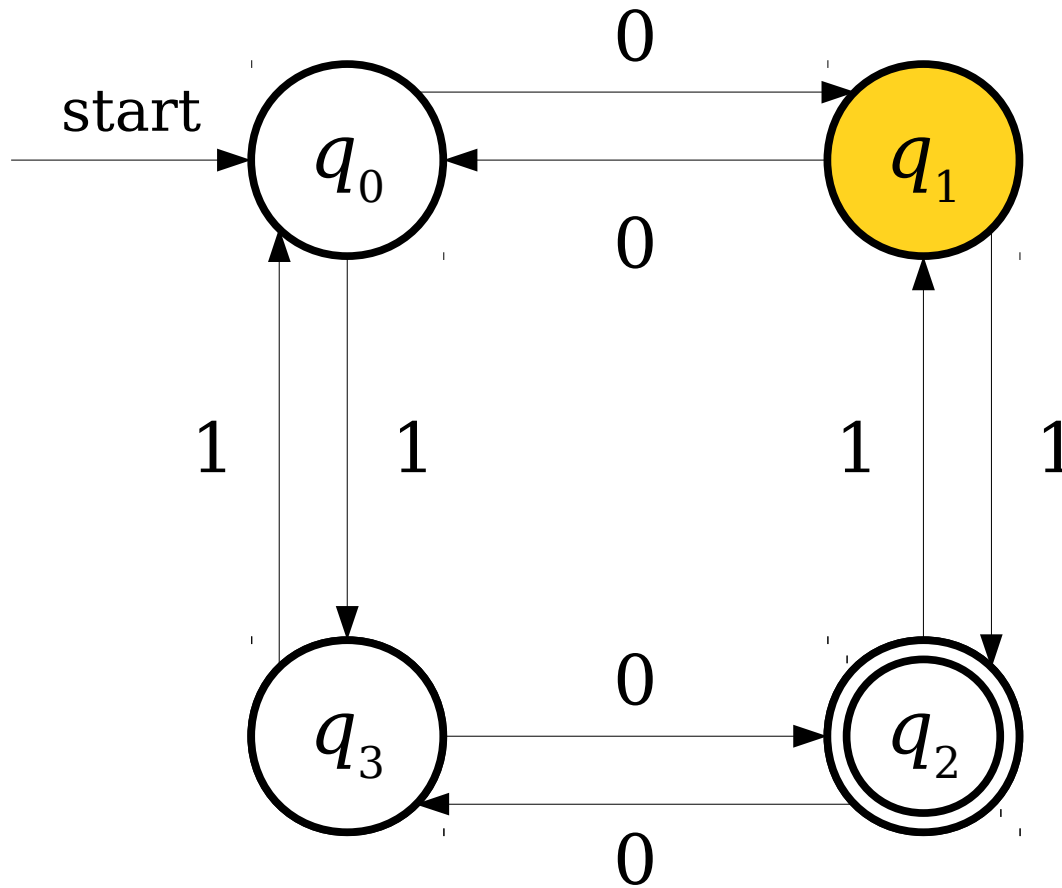

0 1 0 1 1 0

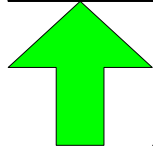

A Simple Finite Automaton

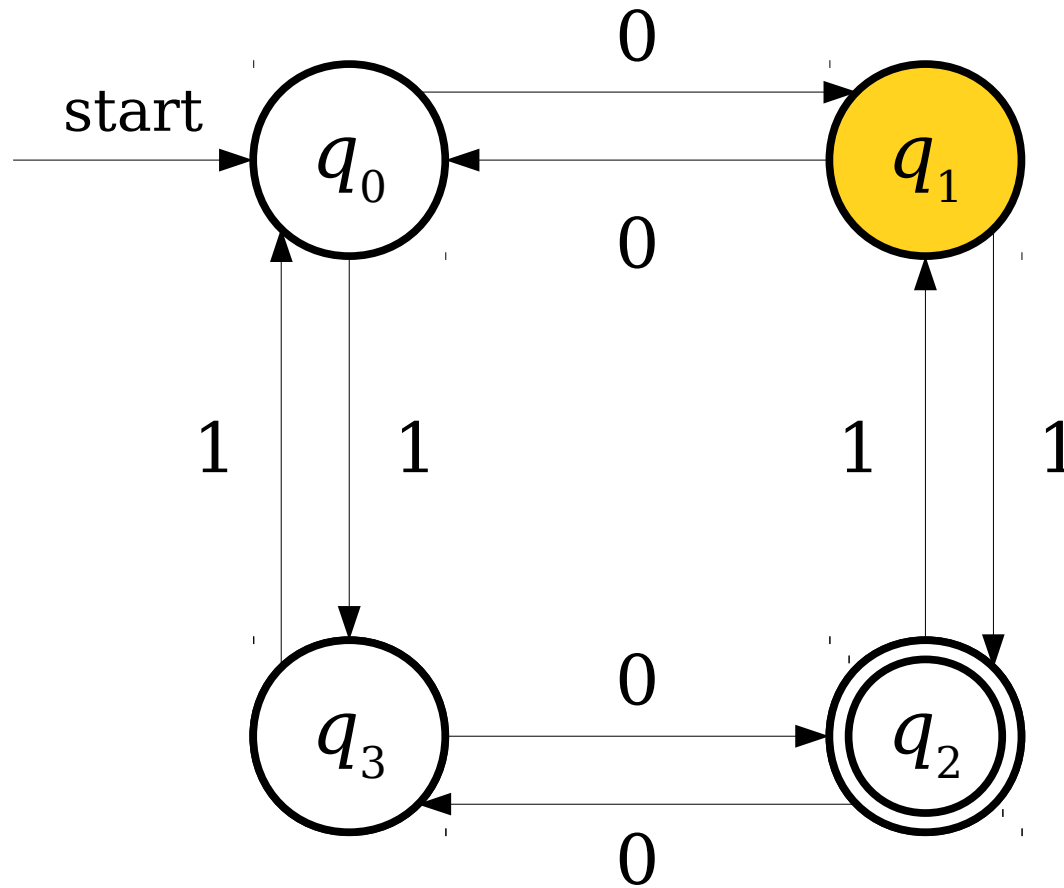

0 1 0 1 1 0

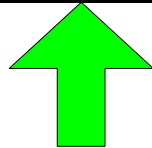

A Simple Finite Automaton

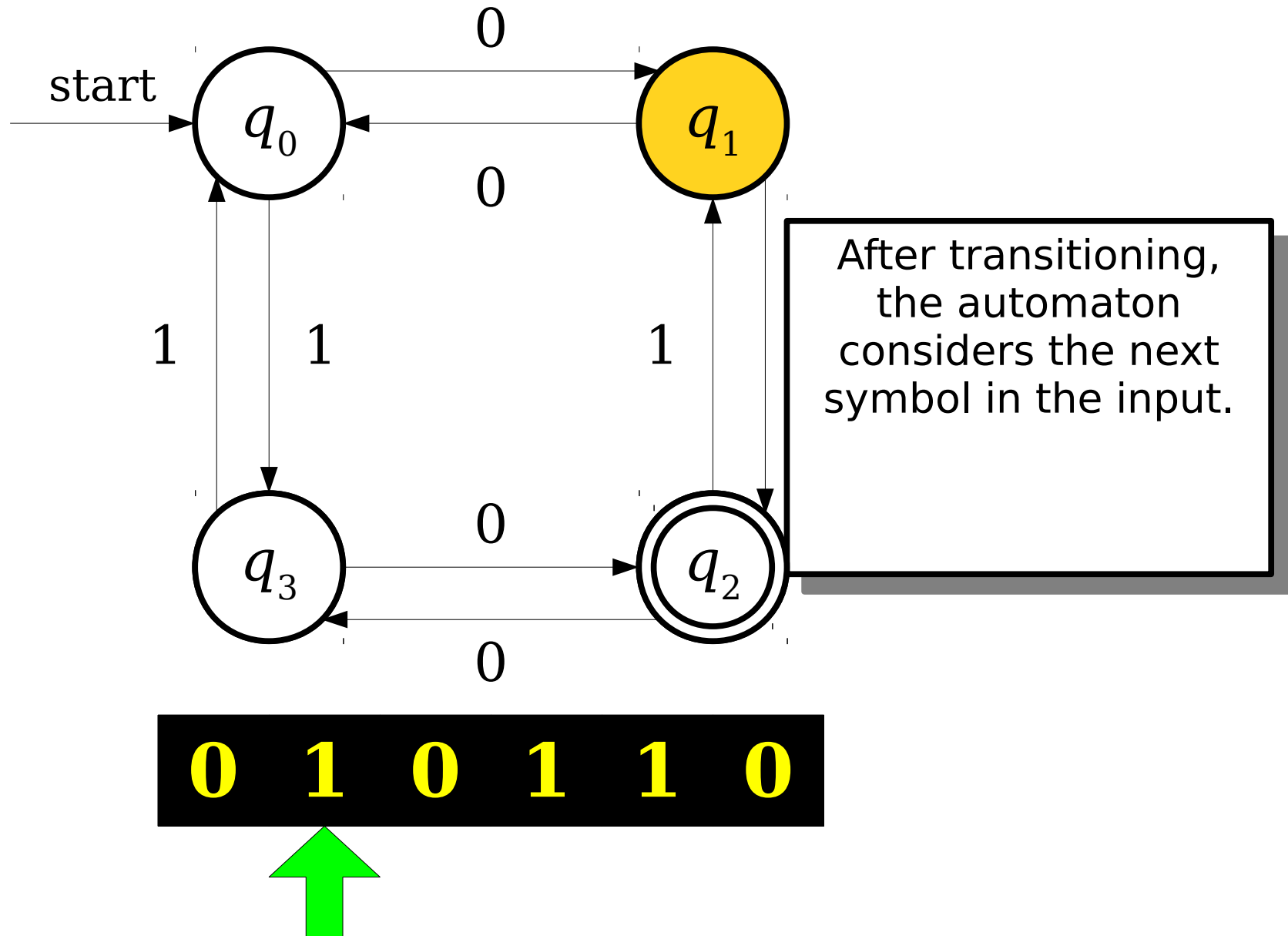

A Simple Finite Automaton

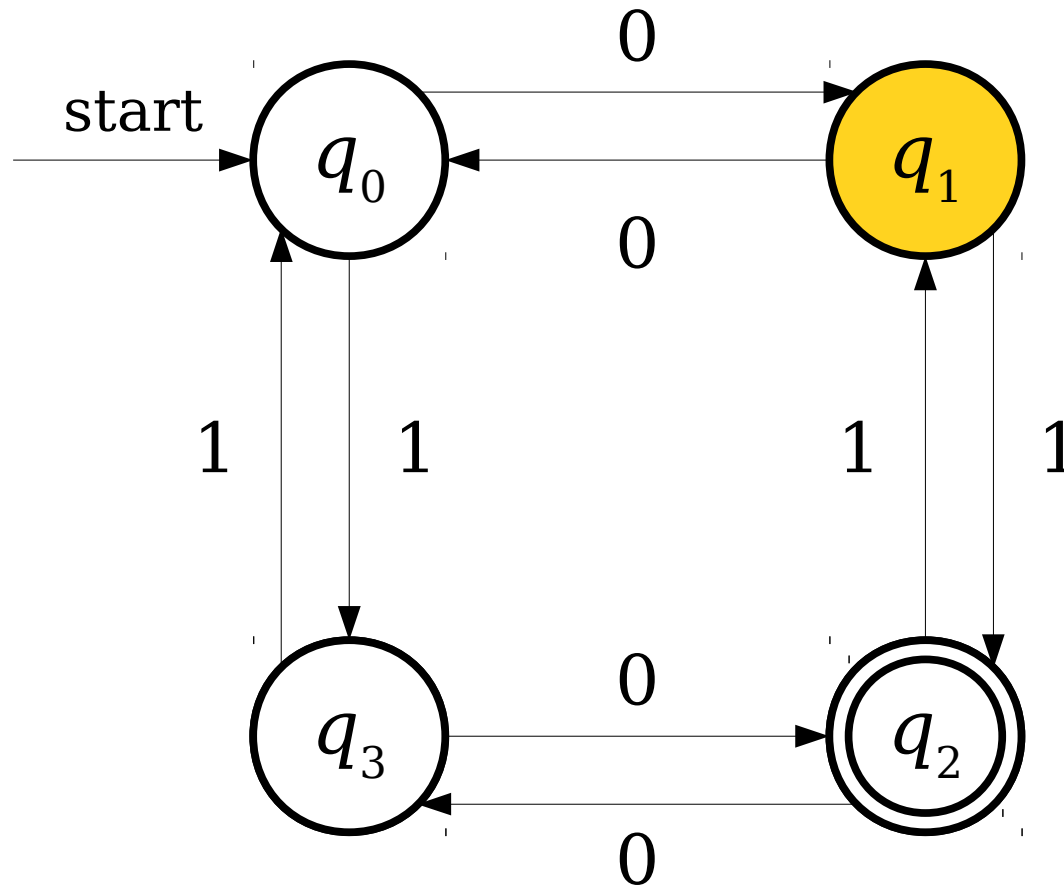

0 1 0 1 1 0

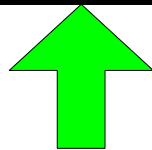

A Simple Finite Automaton

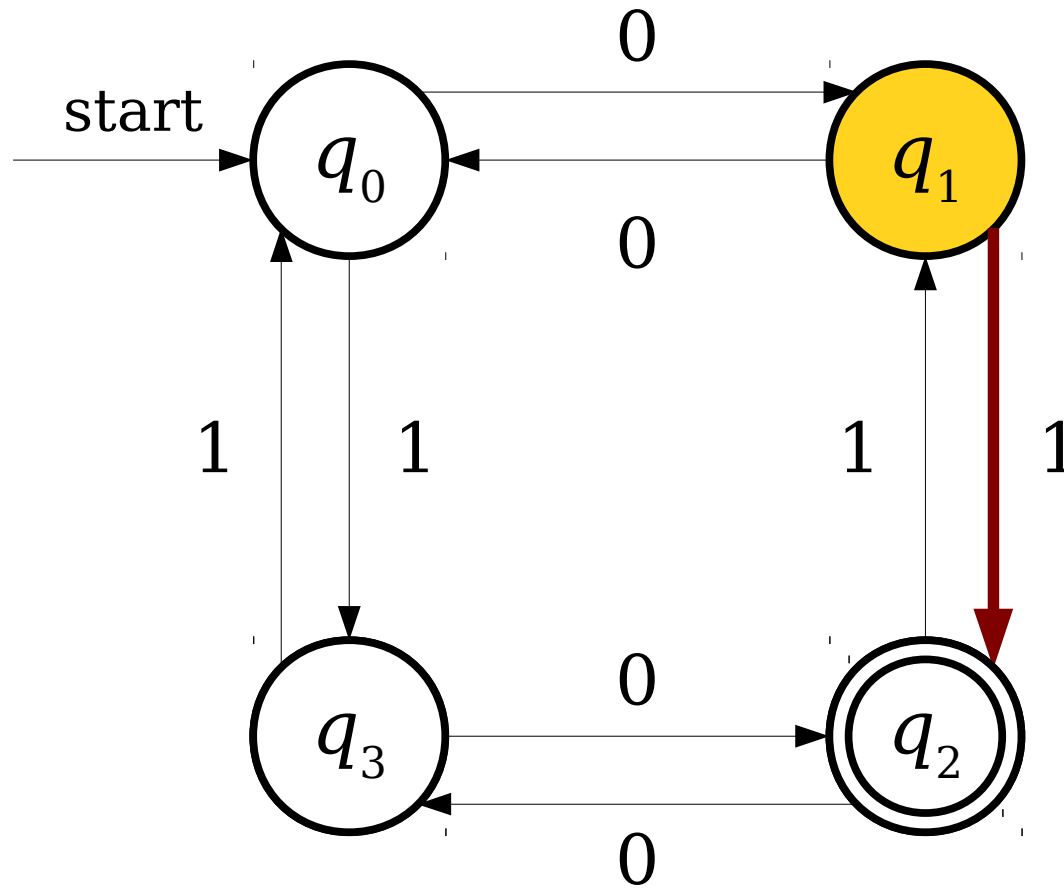

0 1 0 1 1 0

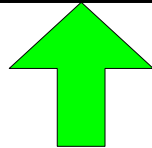

A Simple Finite Automaton

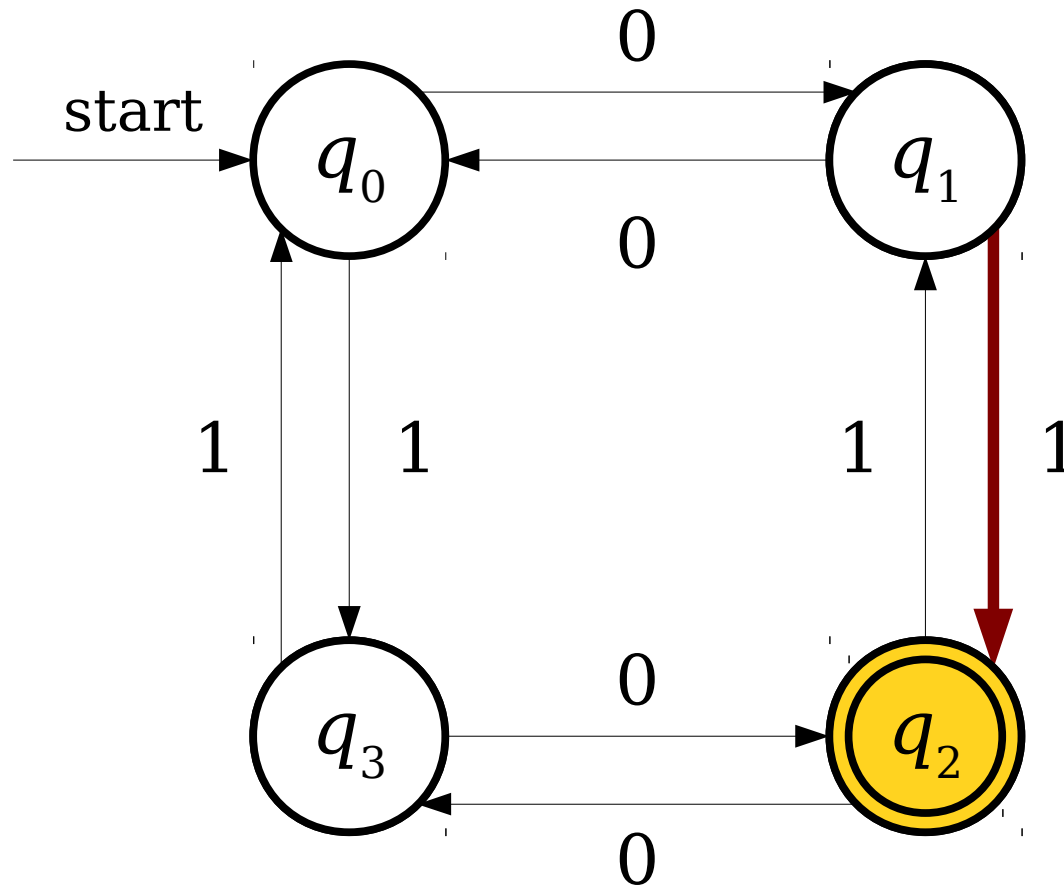

0 1 0 1 1 0

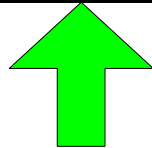

A Simple Finite Automaton

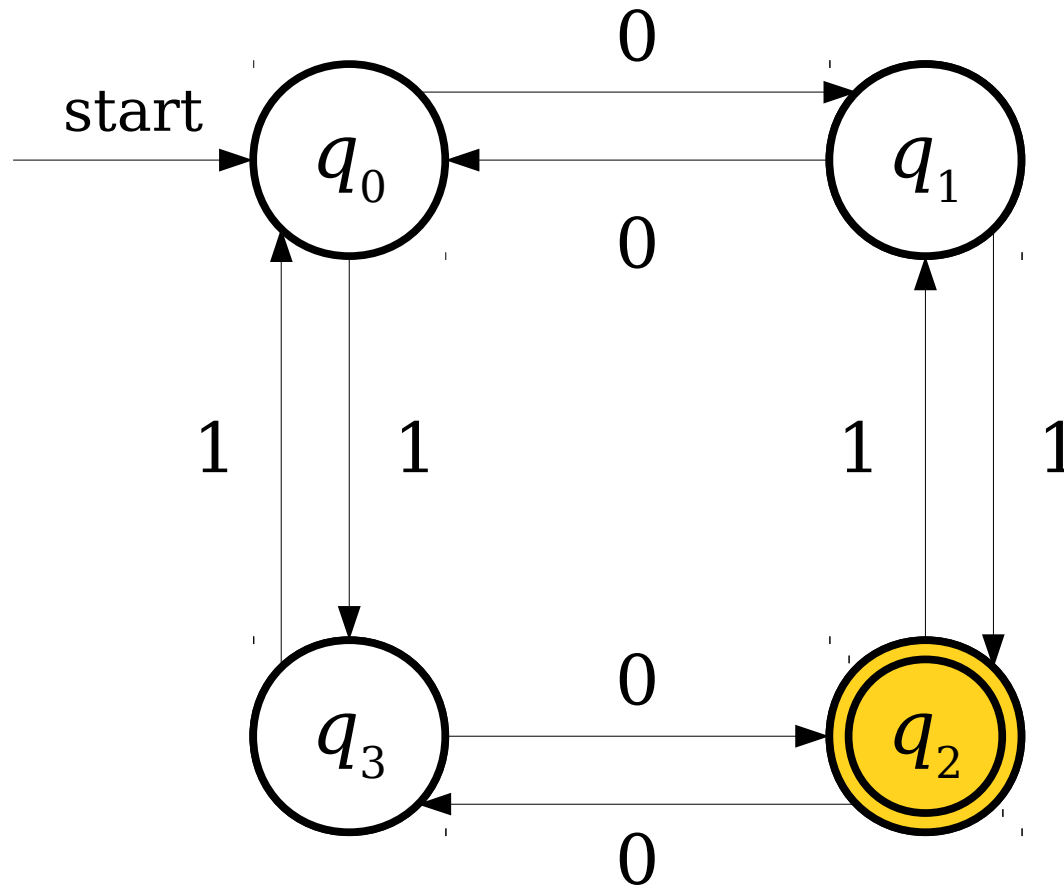

0 1 0 1 1 0

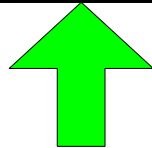

A Simple Finite Automaton

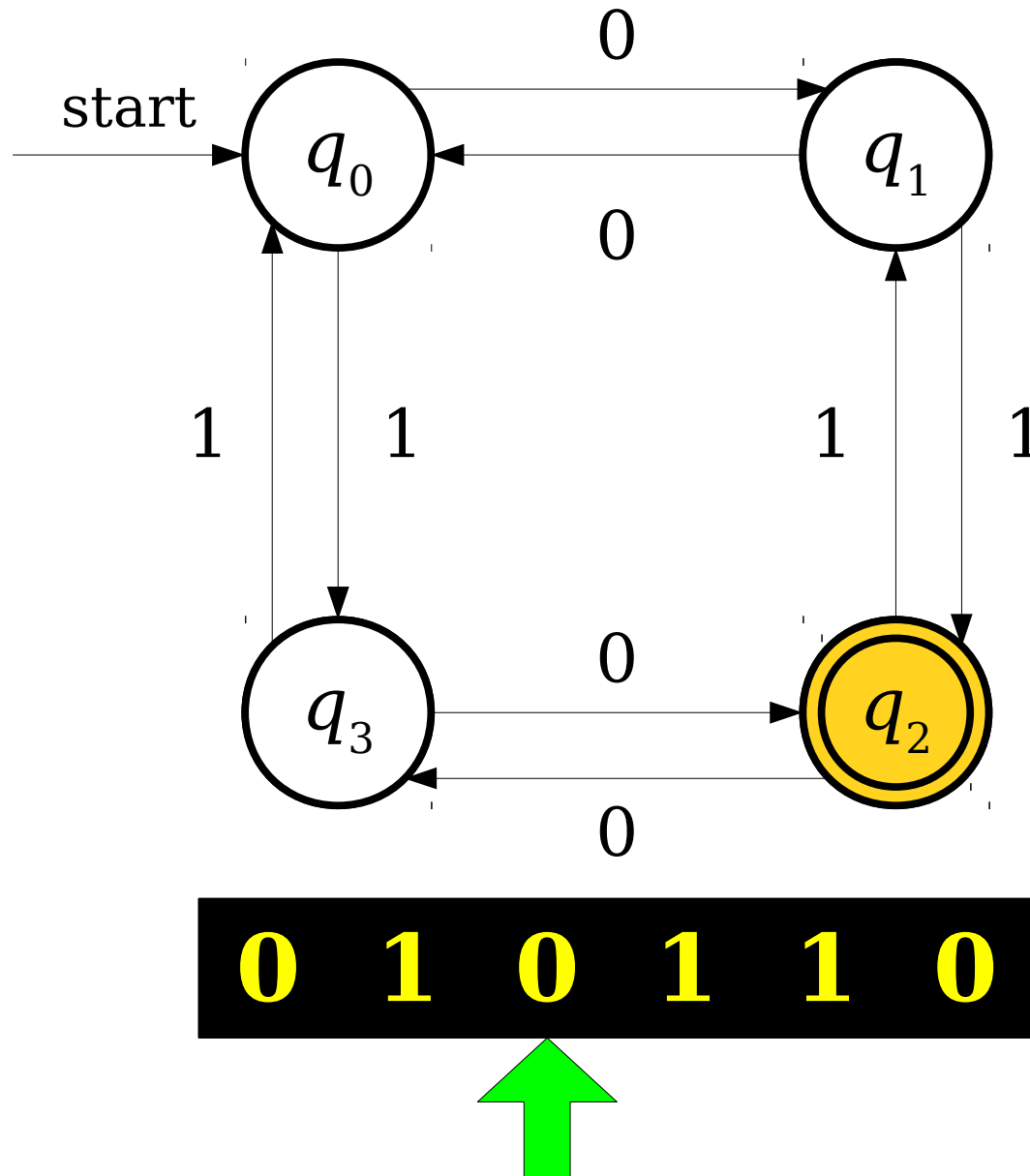

A Simple Finite Automaton

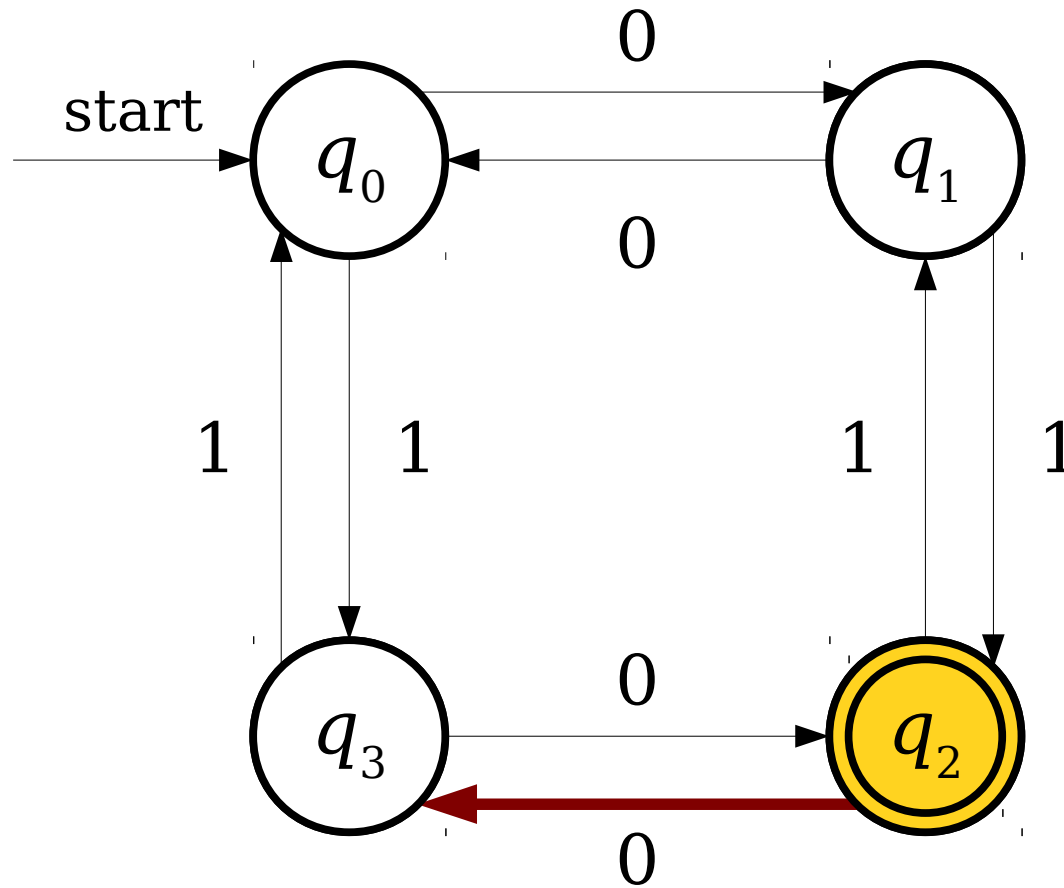

0 1 0 1 1 0

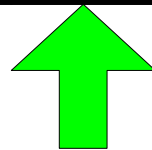

A Simple Finite Automaton

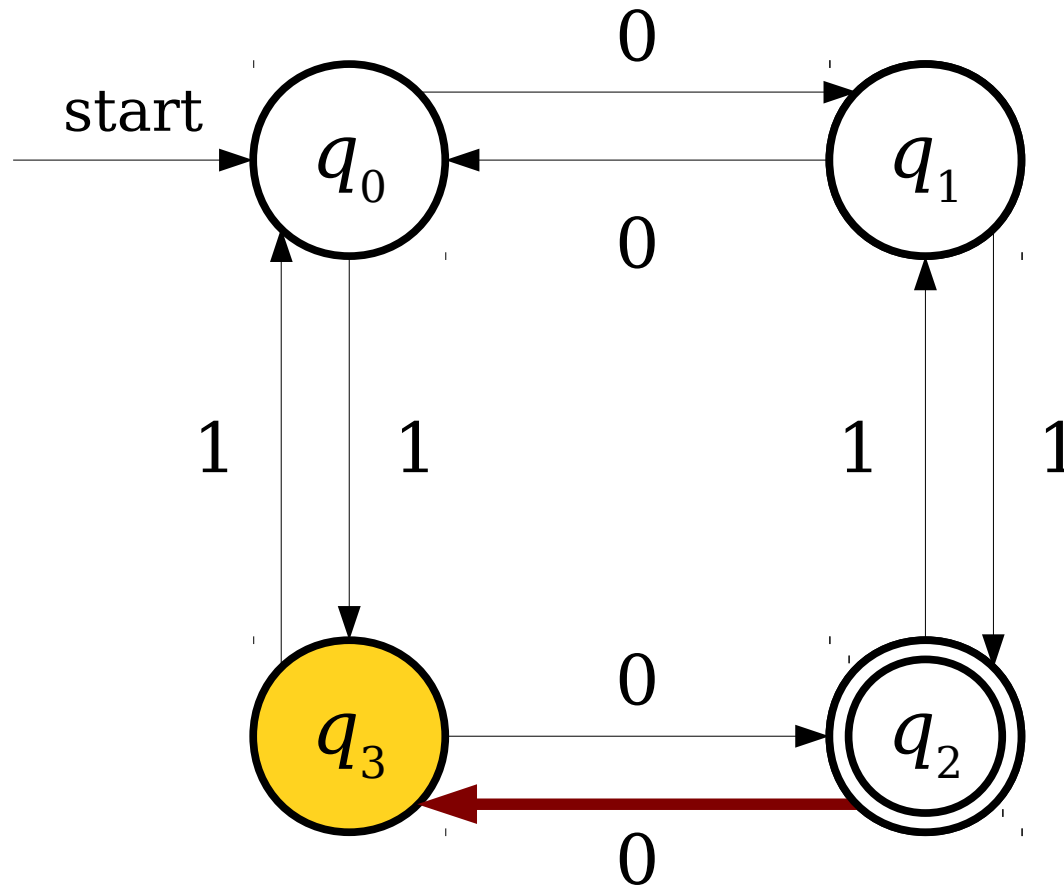

0 1 0 1 1 0

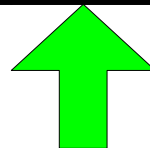

A Simple Finite Automaton

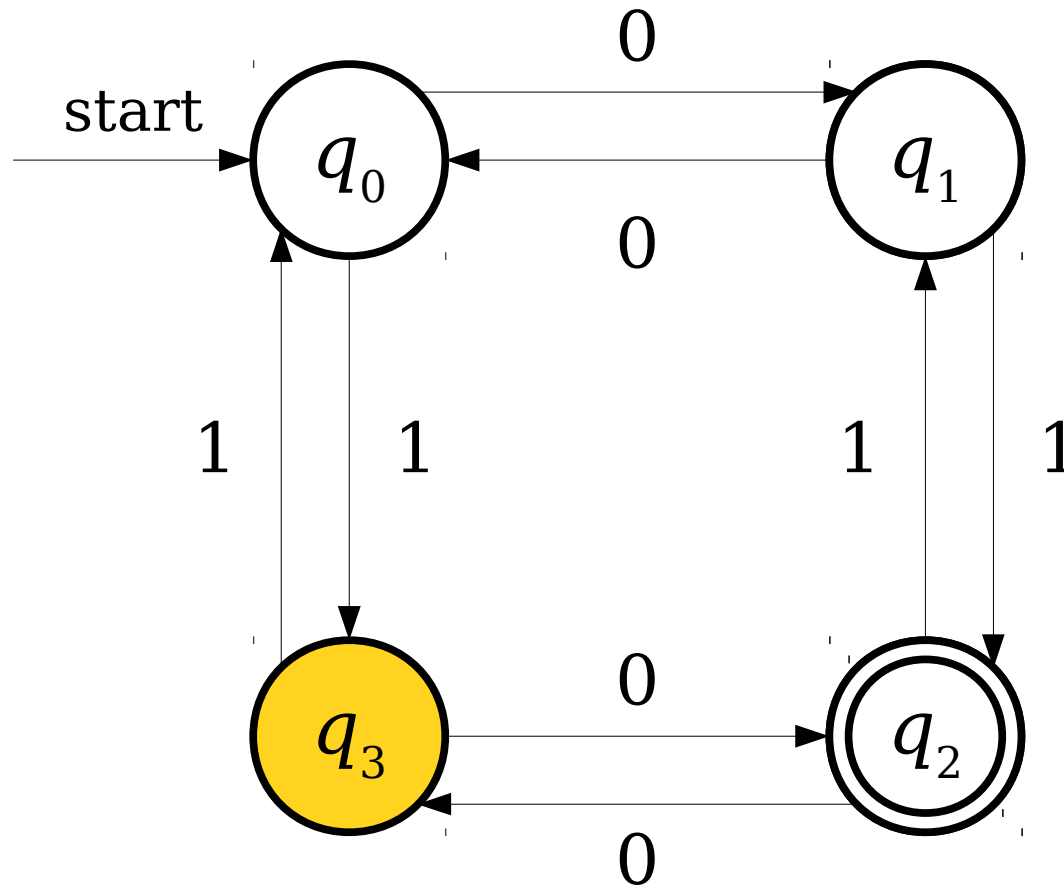

0 1 0 1 1 0

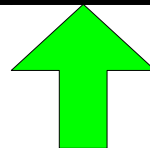

A Simple Finite Automaton

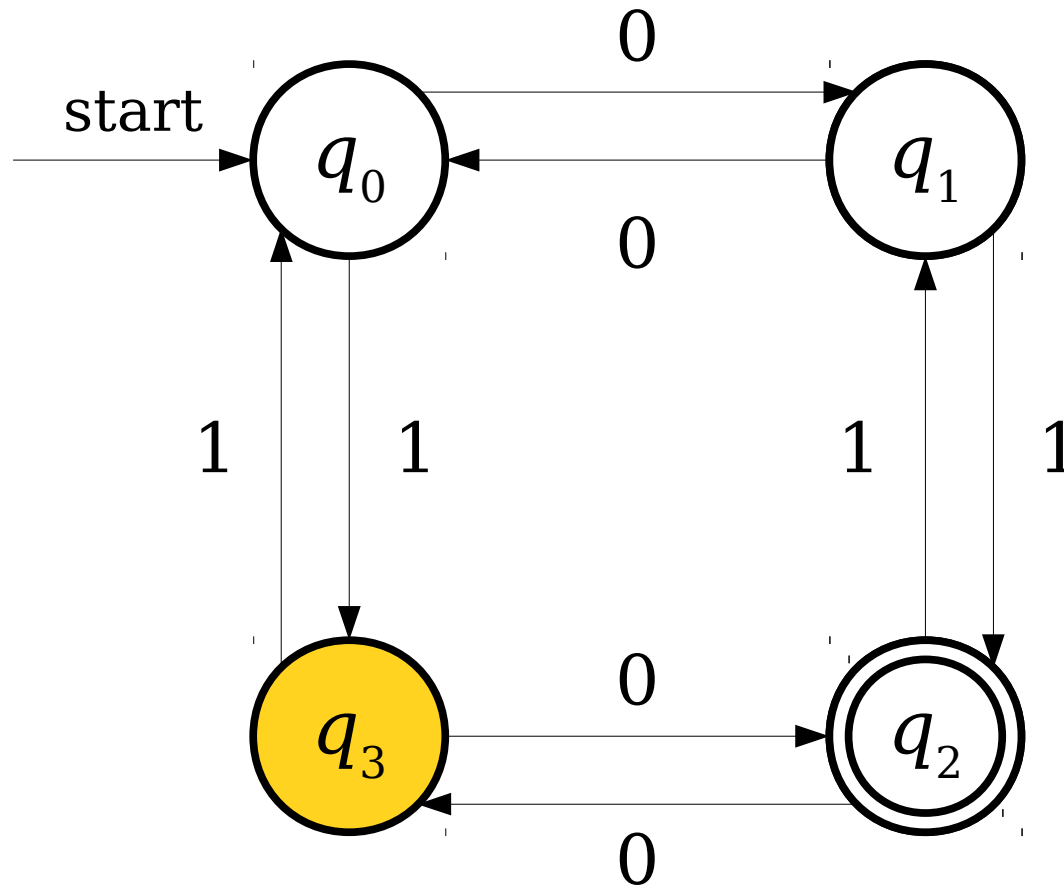

0 1 0 1 1 0

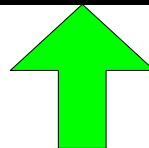

A Simple Finite Automaton

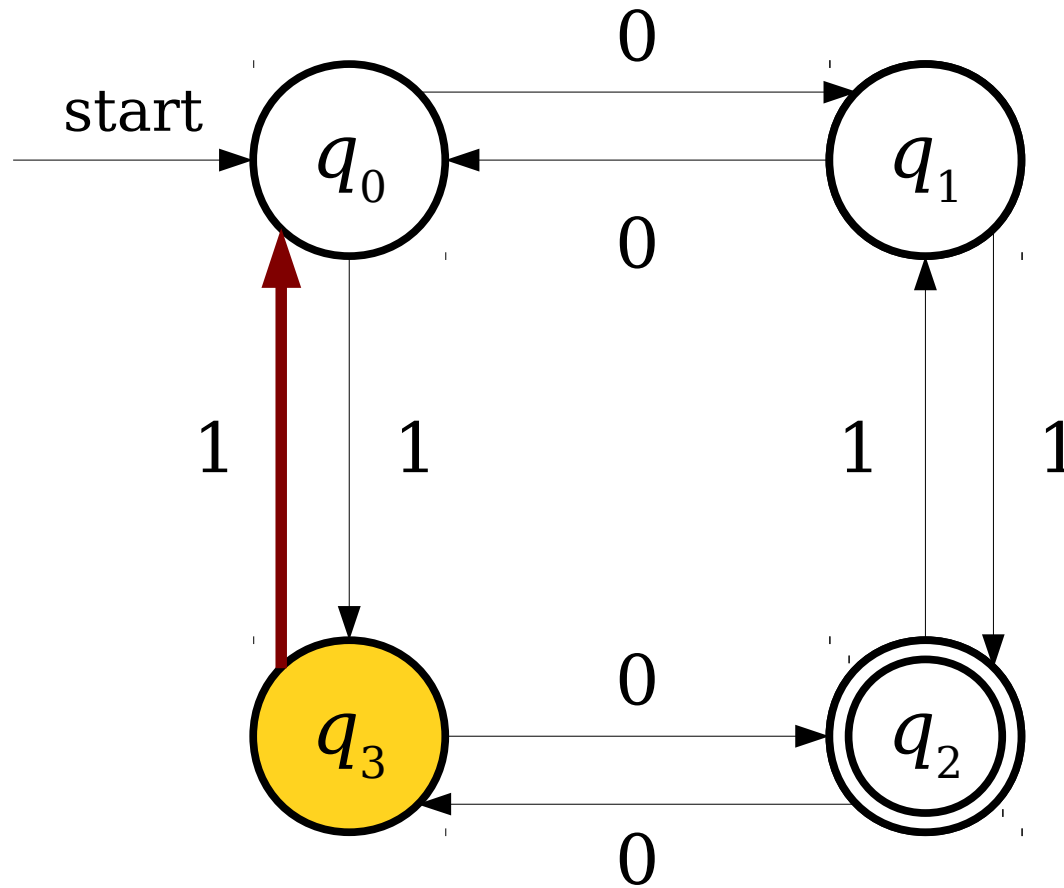

0 1 0 1 1 0

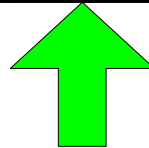

A Simple Finite Automaton

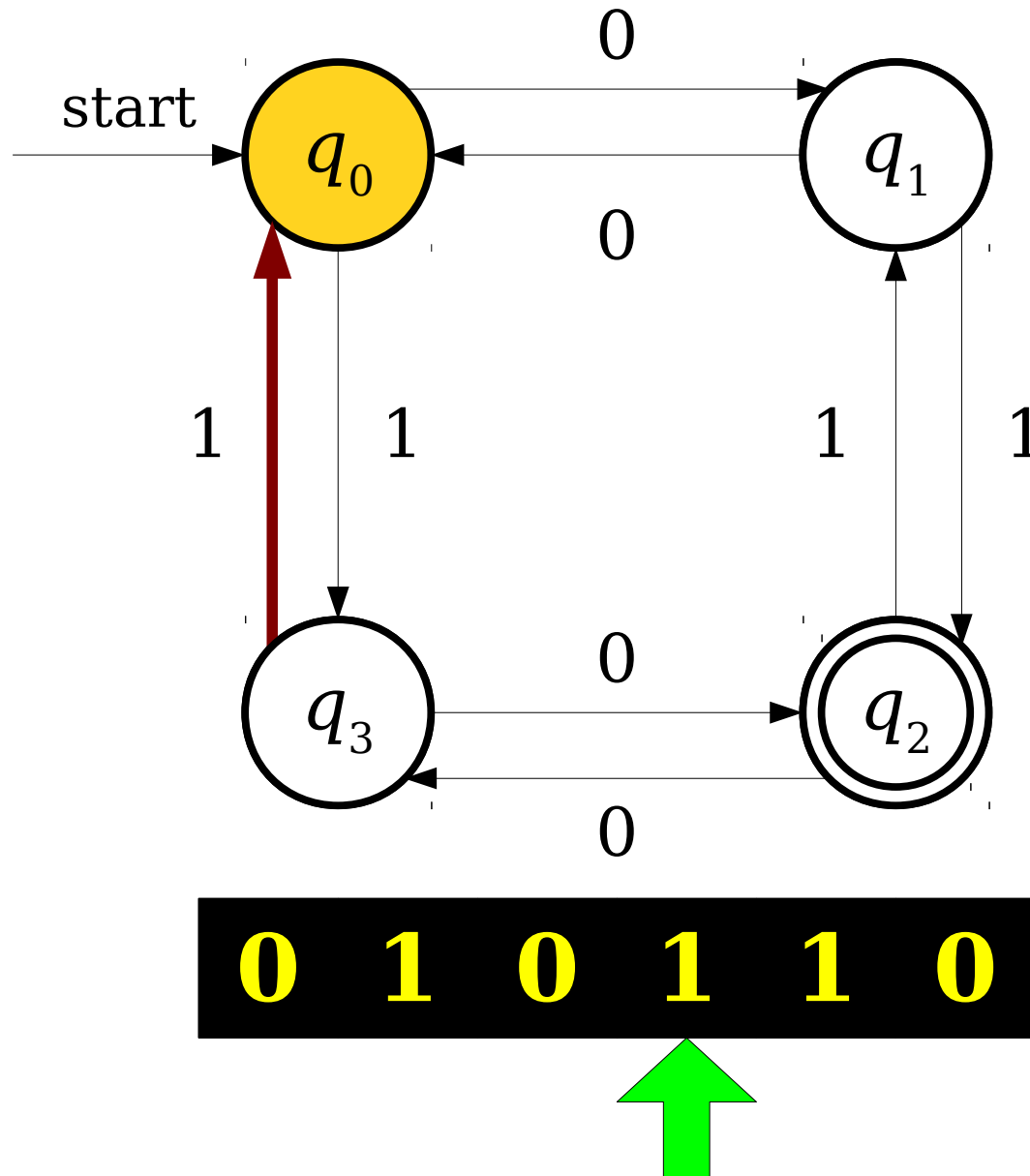

A Simple Finite Automaton

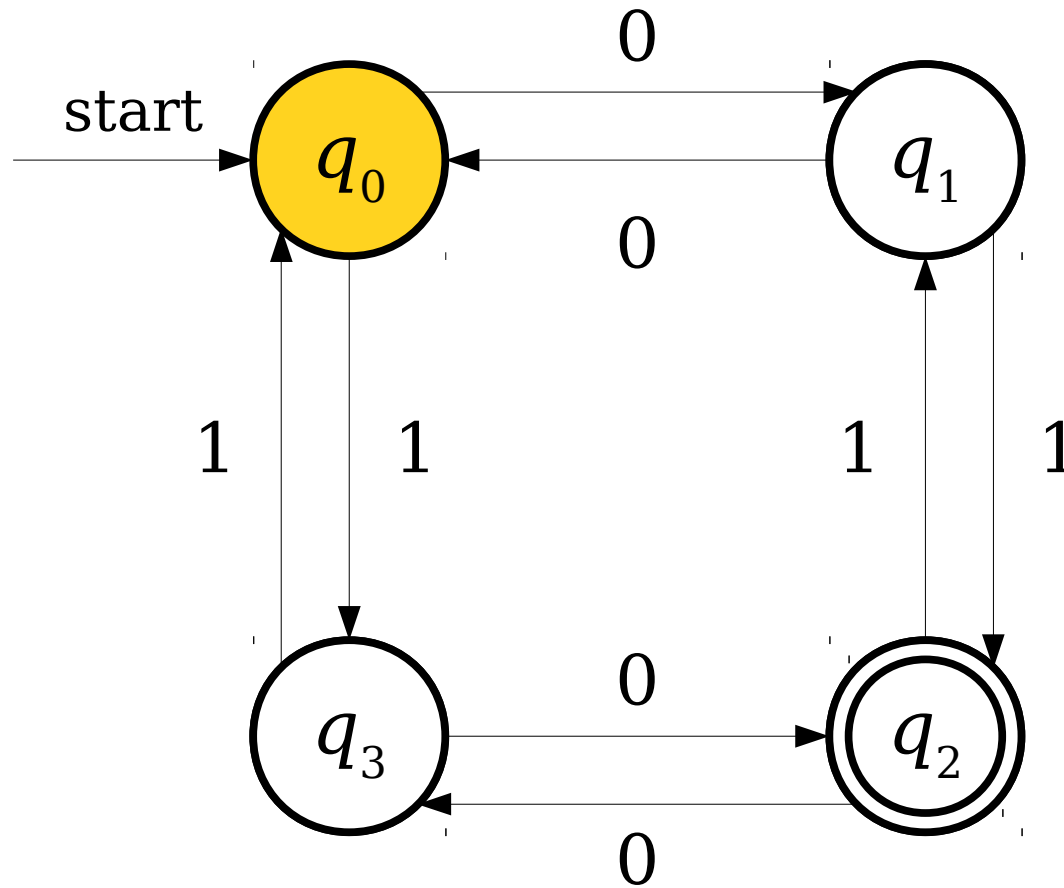

0 1 0 1 1 0

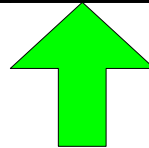

A Simple Finite Automaton

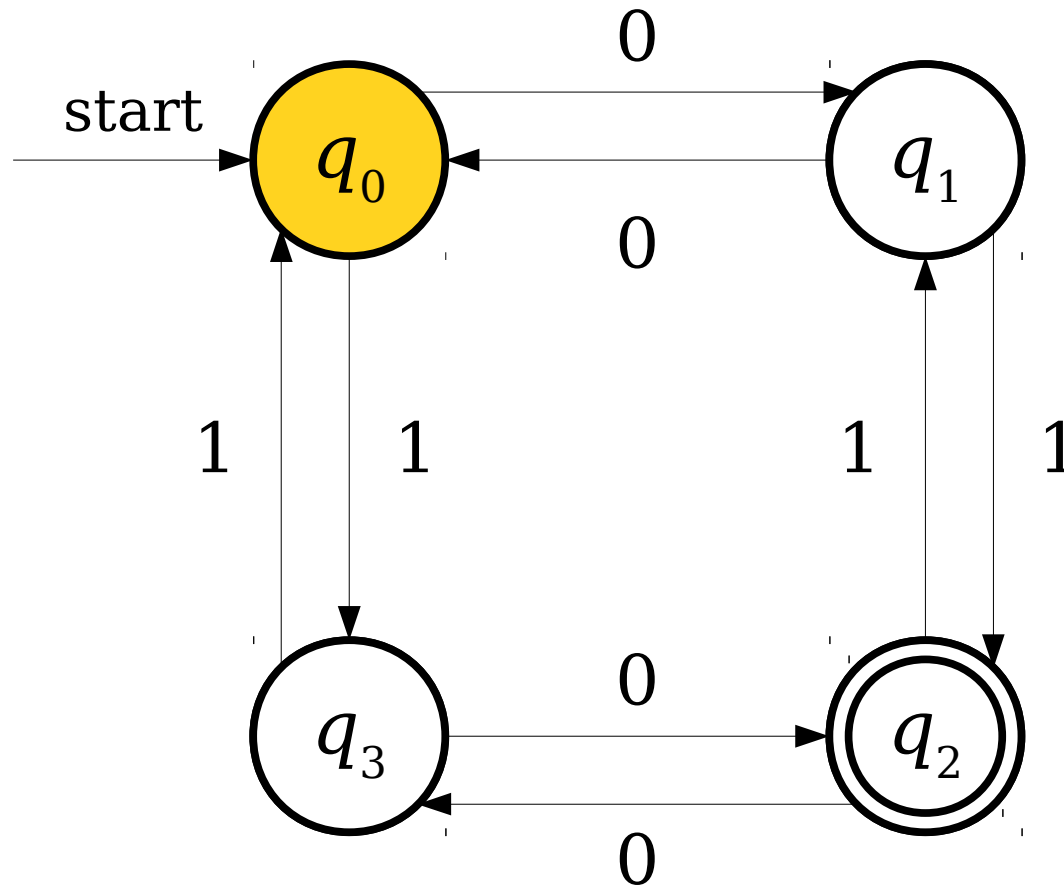

0 1 0 1 1 0

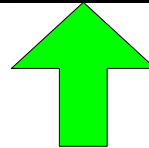

A Simple Finite Automaton

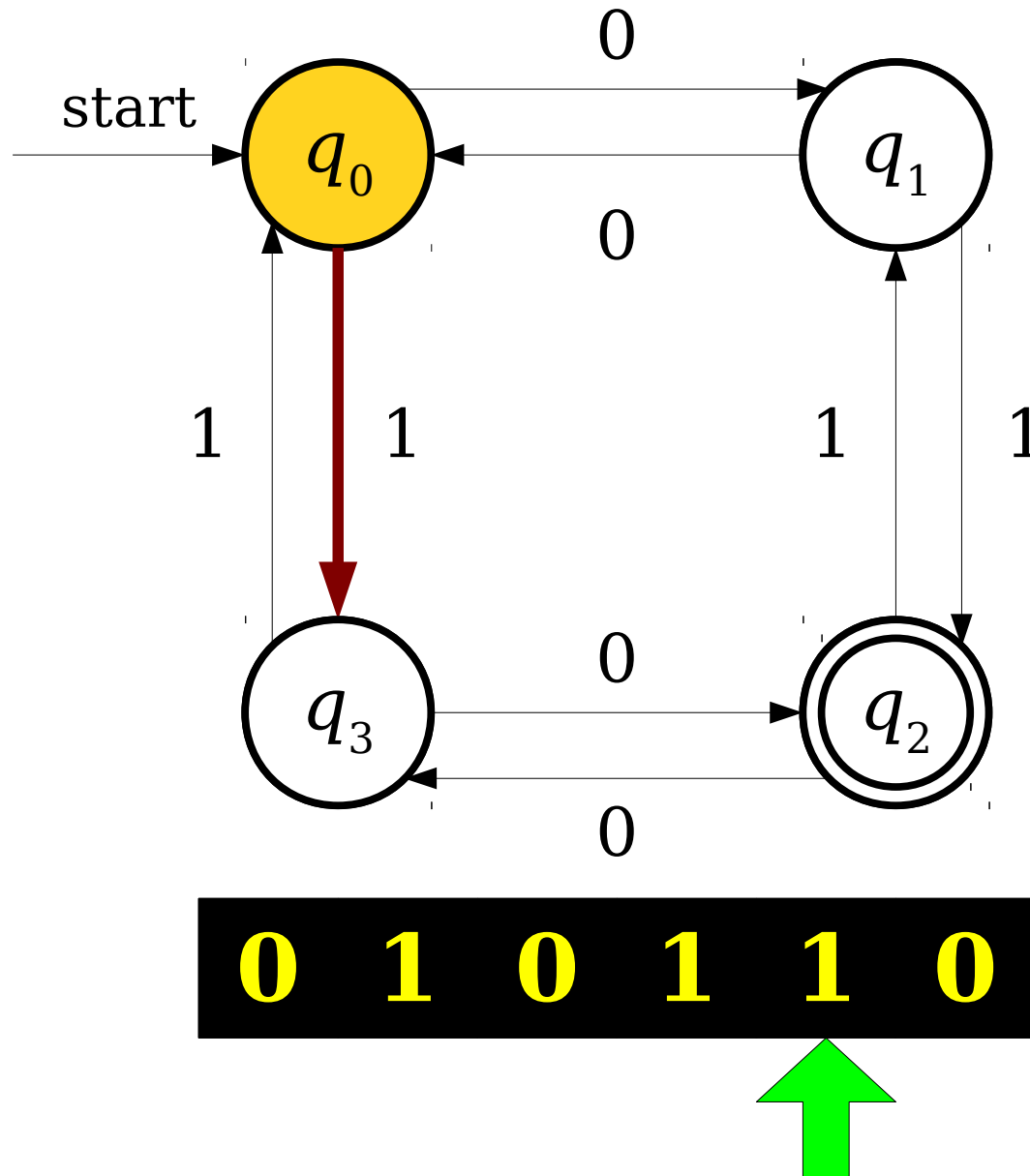

A Simple Finite Automaton

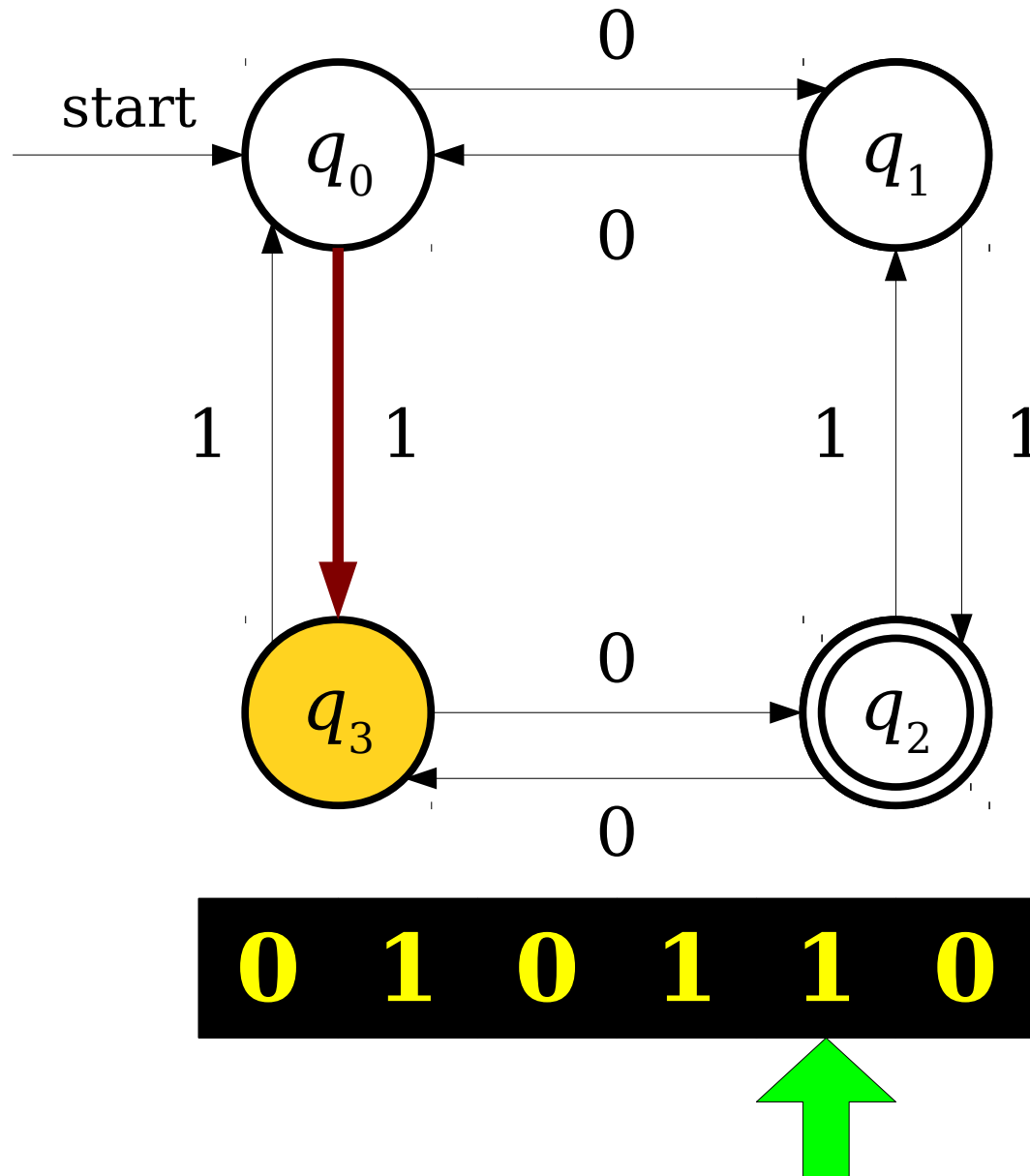

A Simple Finite Automaton

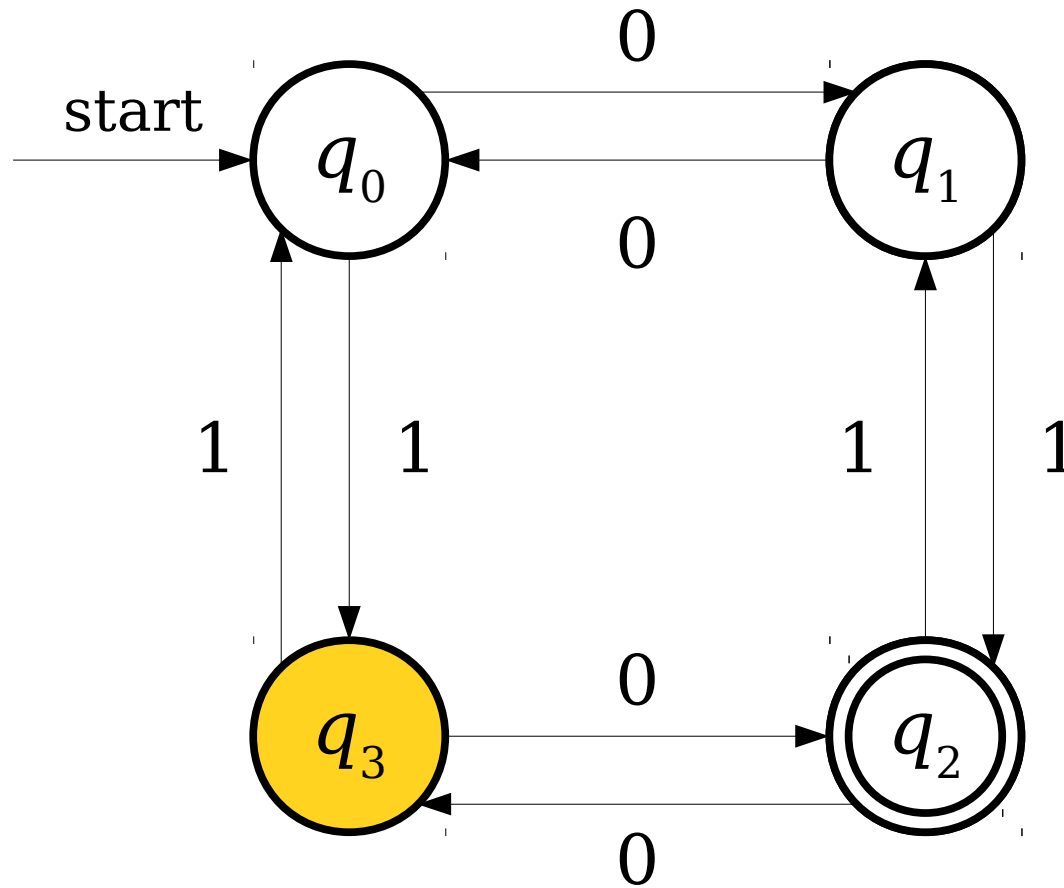

0 1 0 1 1 0



A Simple Finite Automaton

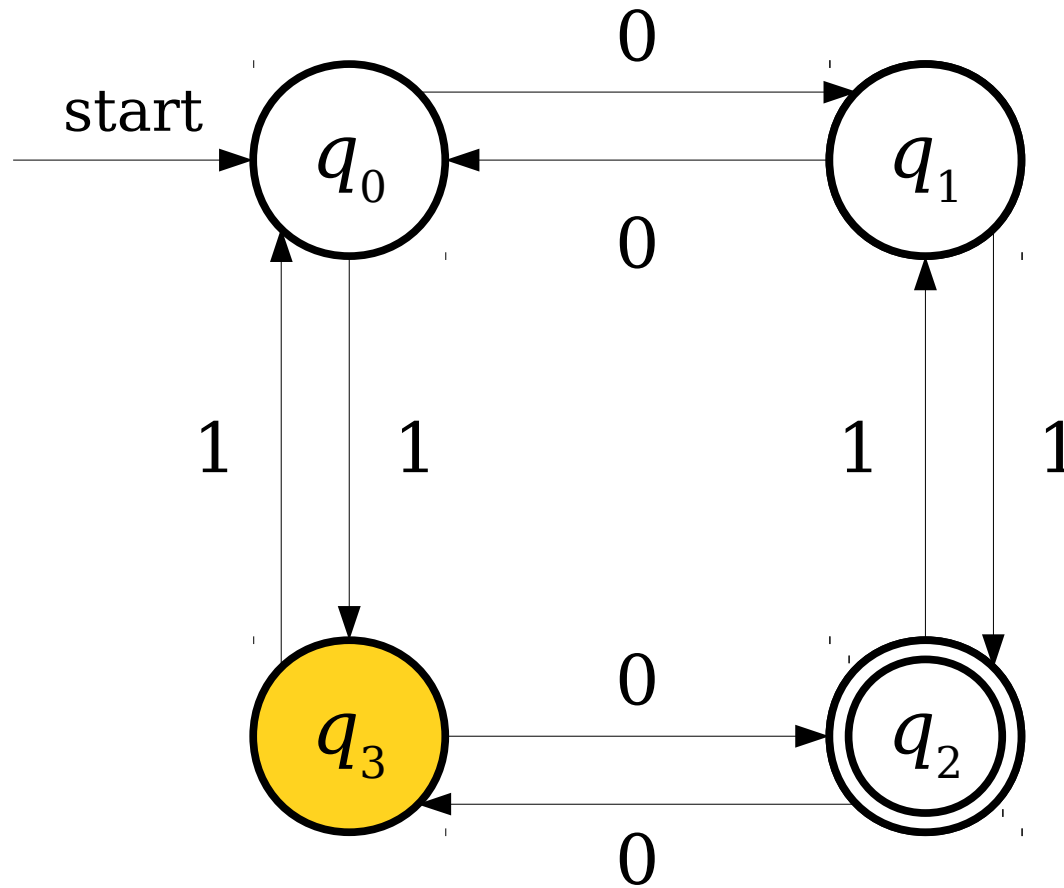

0 1 0 1 1 0



A Simple Finite Automaton

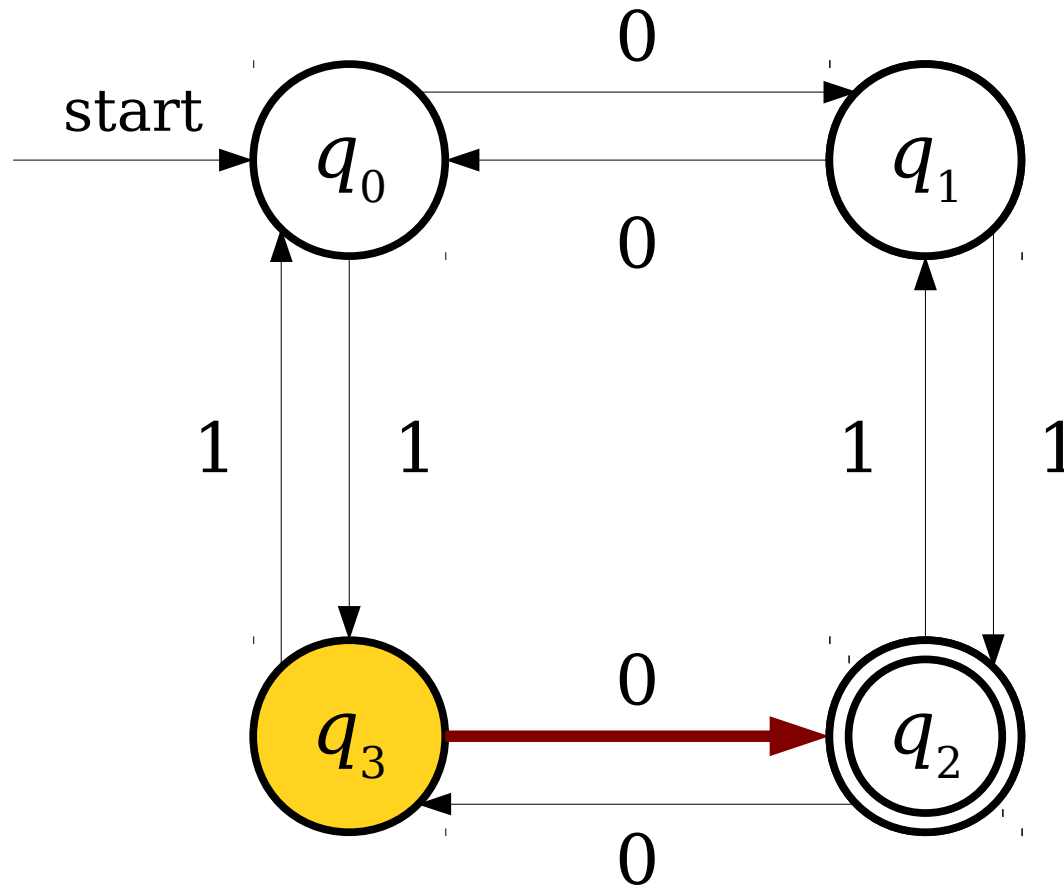

0 1 0 1 1 0



A Simple Finite Automaton

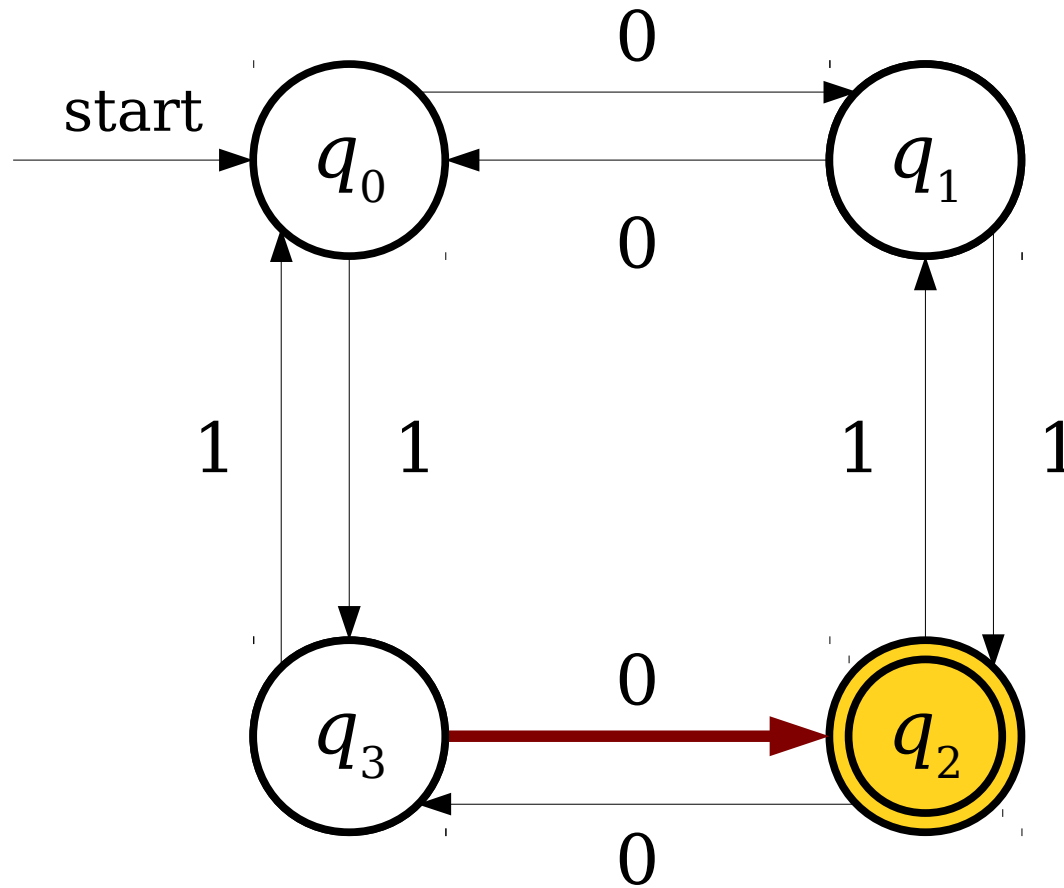

0 1 0 1 1 0



A Simple Finite Automaton

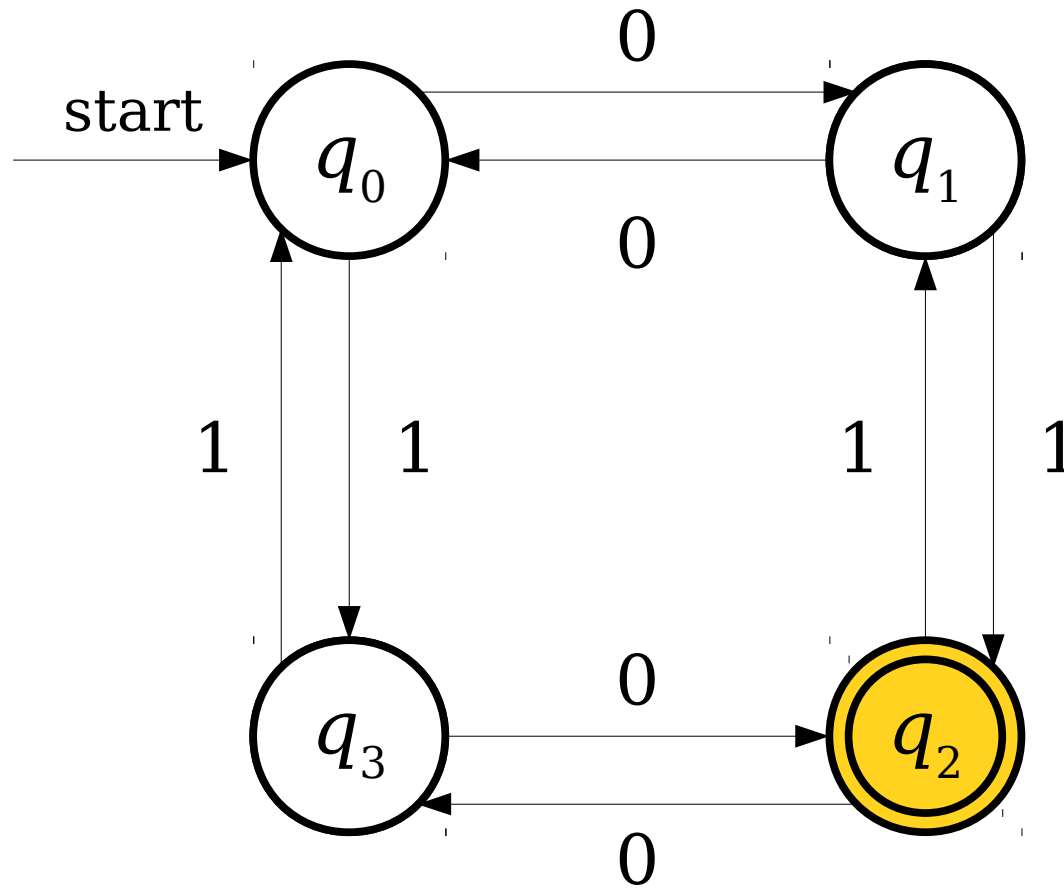

0 1 0 1 1 0

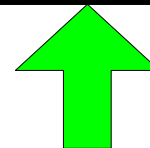

A Simple Finite Automaton

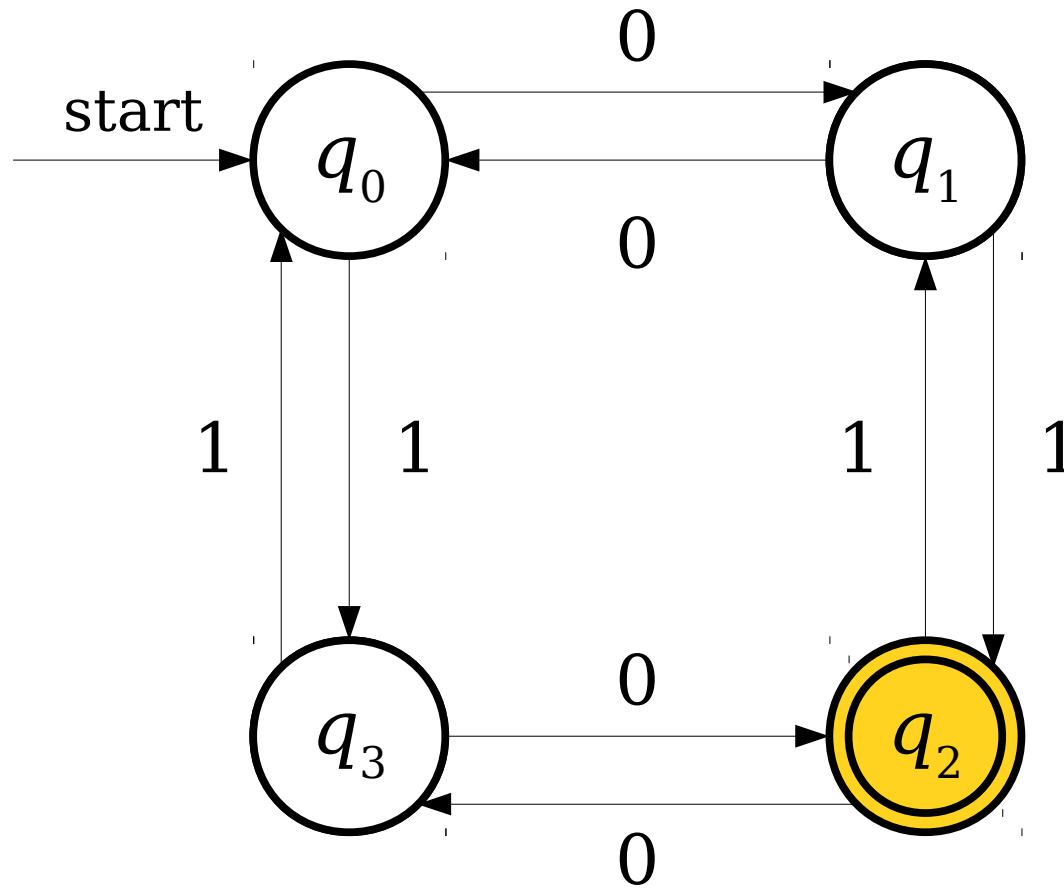

0 1 0 1 1 0

A Simple Finite Automaton

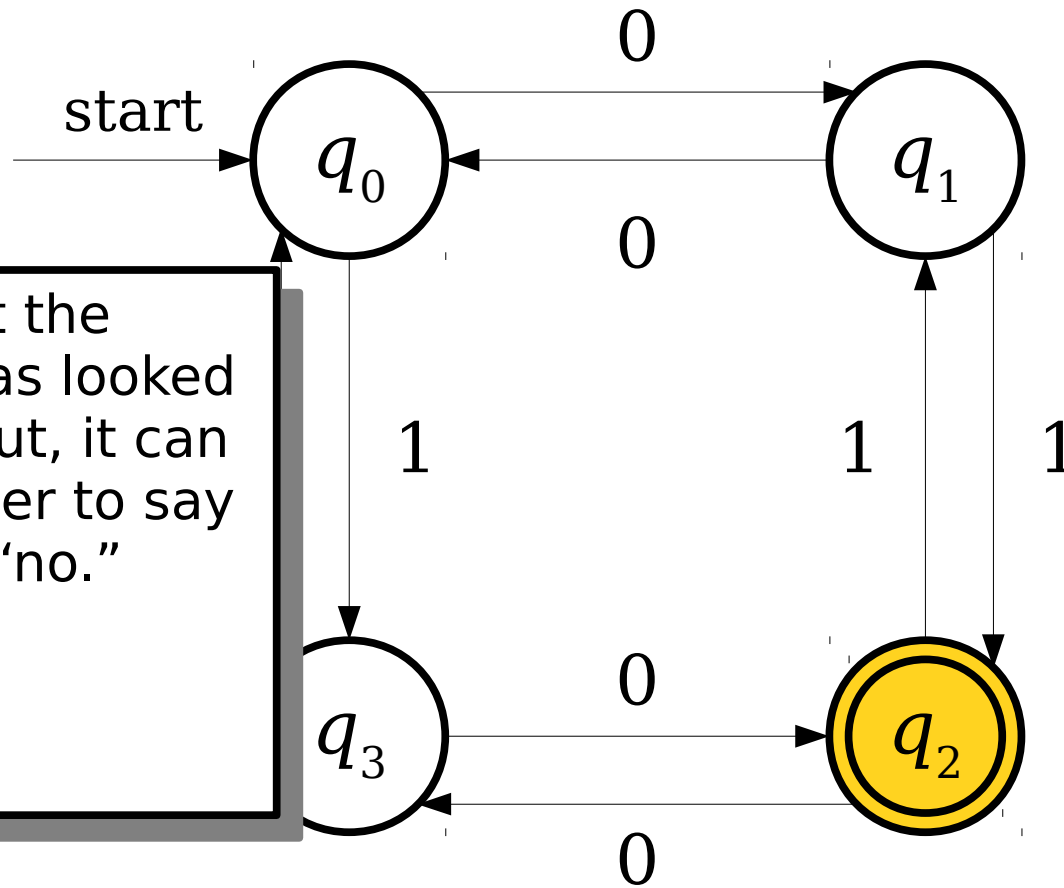

Now that the automaton has looked at all this input, it can decide whether to say "yes" or "no."

0 1 0 1 1 0

A Simple Finite Automaton

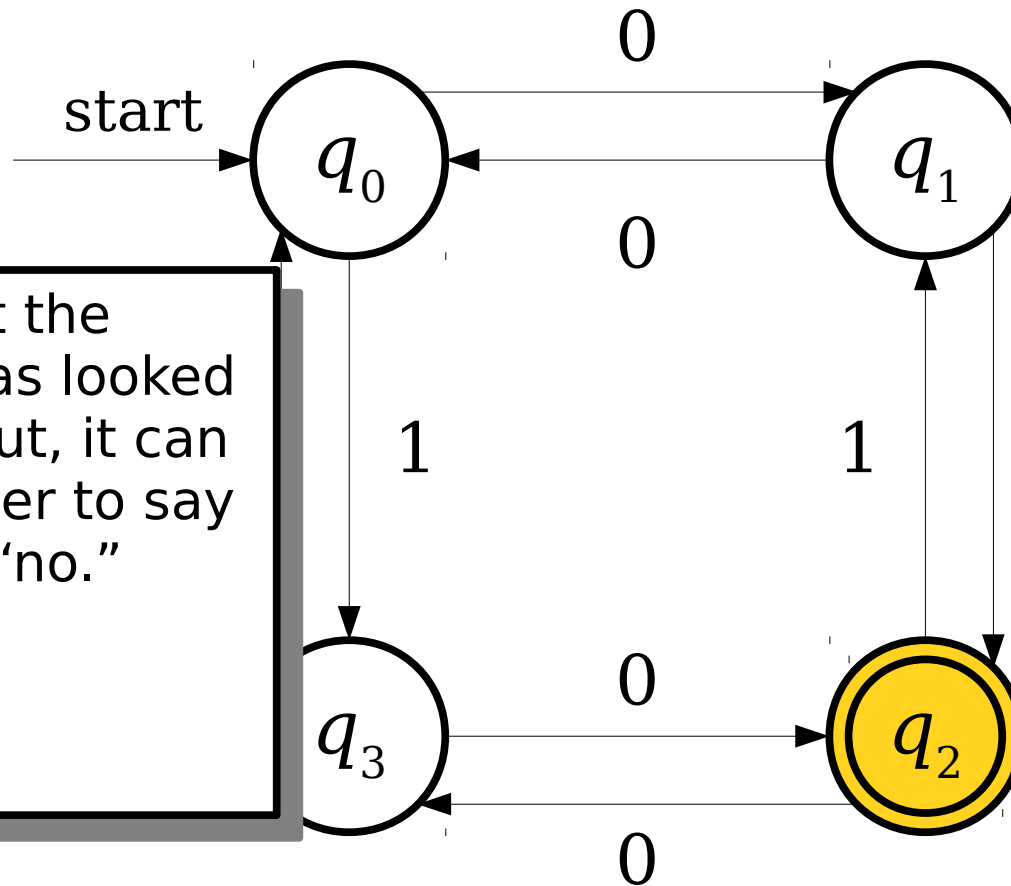

Now that the automaton has looked at all this input, it can decide whether to say “yes” or “no.”

The double circle indicates that this state is an **accepting state**, so the automaton outputs “yes.”

0 1 0 1 1 0

A Simple Finite Automaton

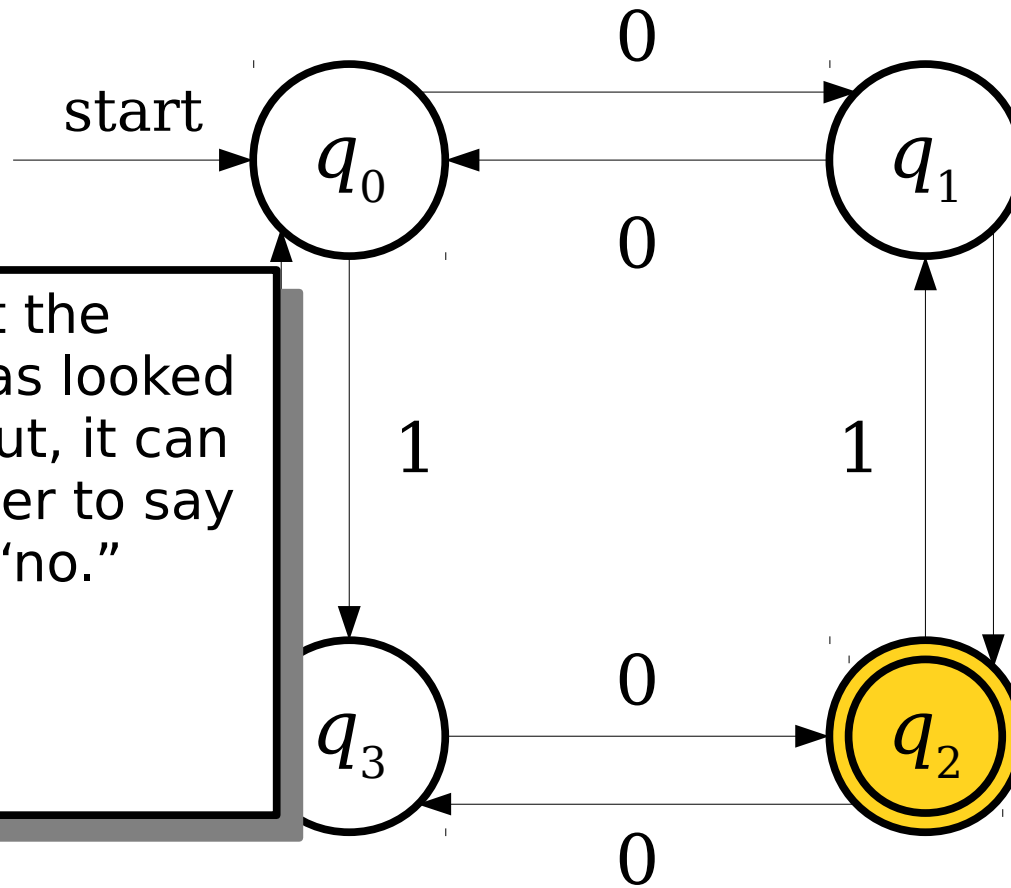

Now that the automaton has looked at all this input, it can decide whether to say “yes” or “no.”

The double circle indicates that this state is an **accepting state**, so the automaton outputs “yes.”

0 1 0 1 1 0

A Simple Finite Automaton

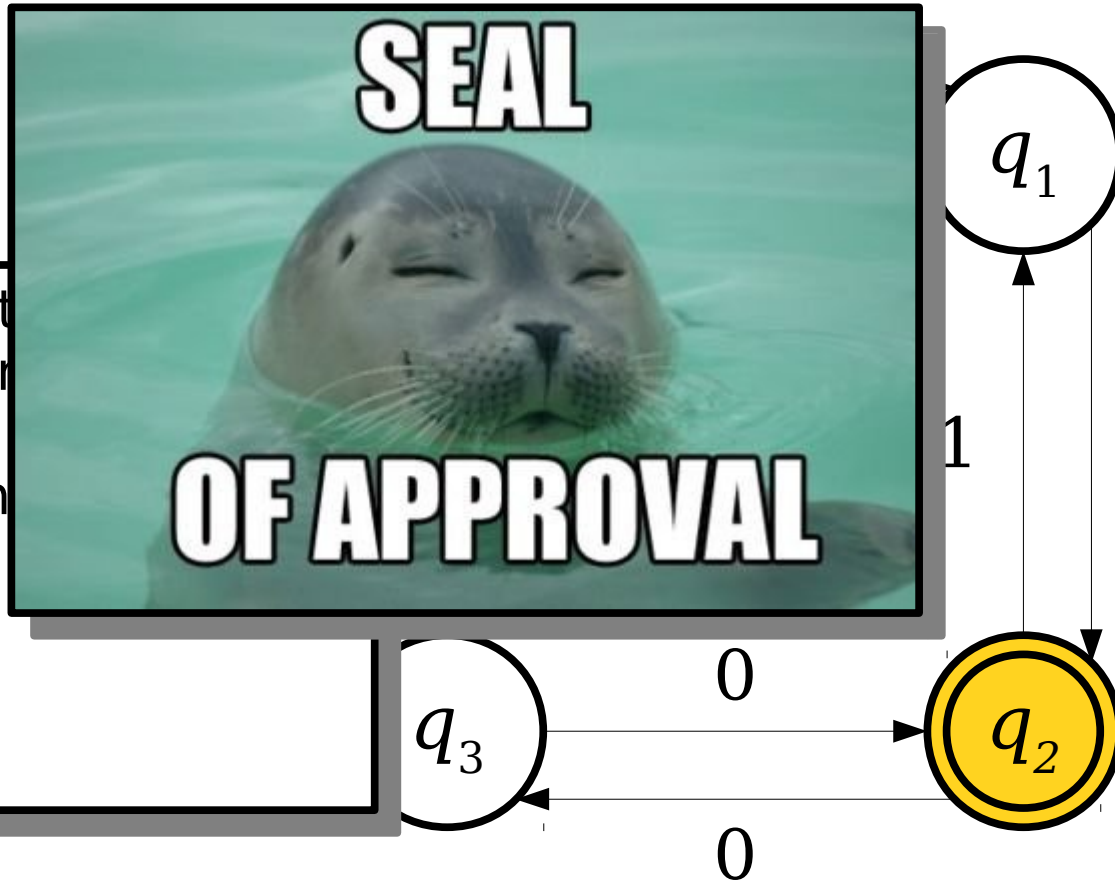

Now the automaton has to decide whether to output "yes" or "no" at all this point.

The double circle indicates that this state is an **accepting state**, so the automaton outputs "yes."

0 1 0 1 1 0

A Simple Finite Automaton

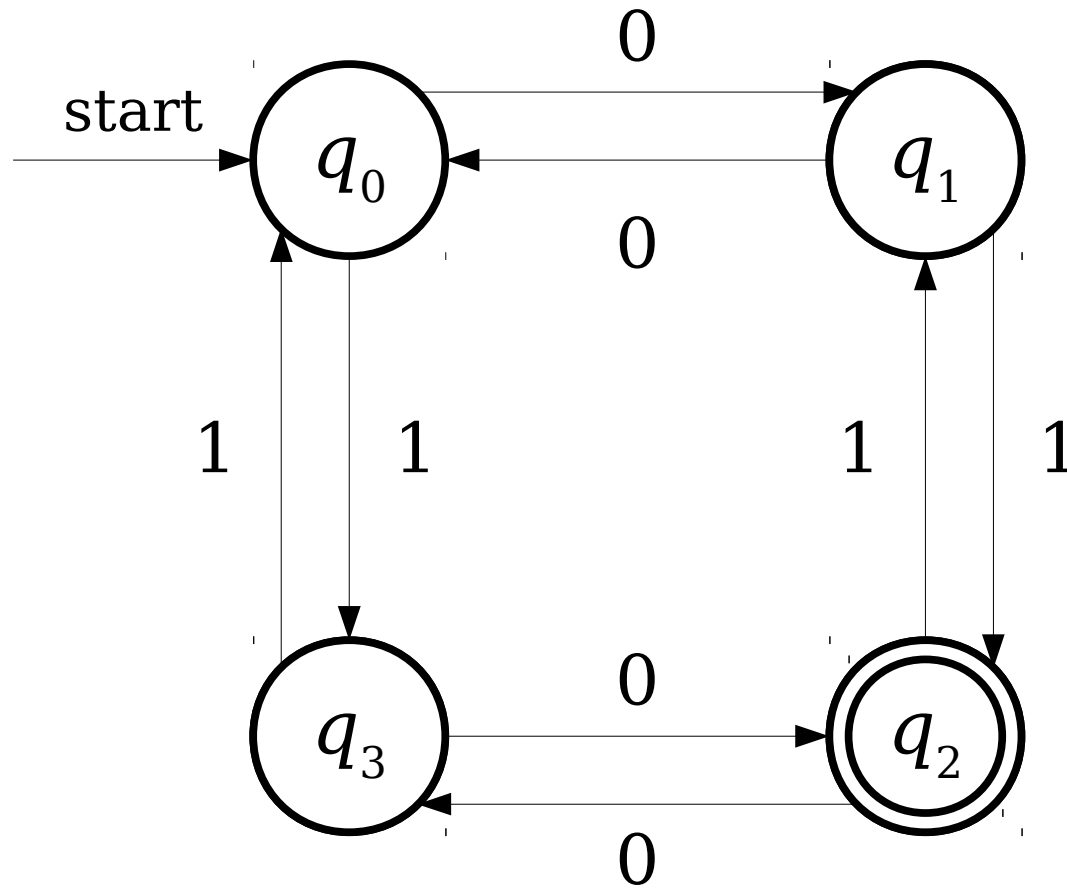

A Simple Finite Automaton

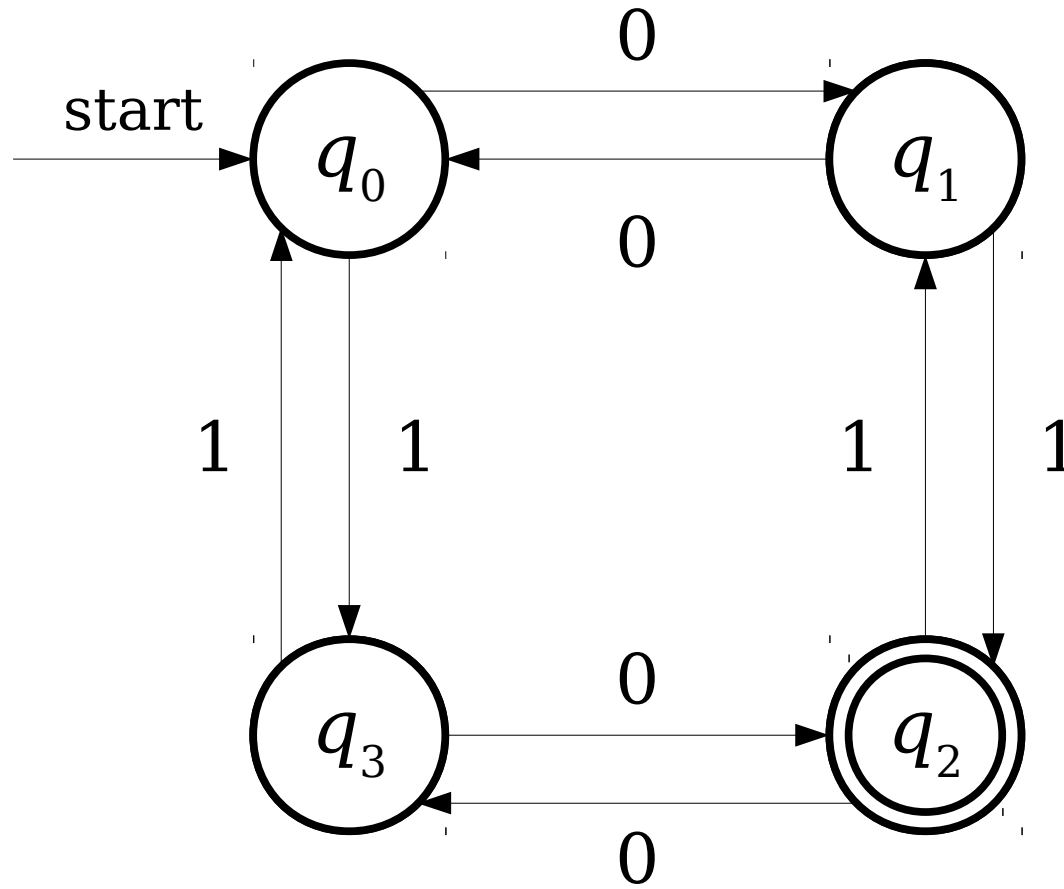

1 0 1 0 0 0

A Simple Finite Automaton

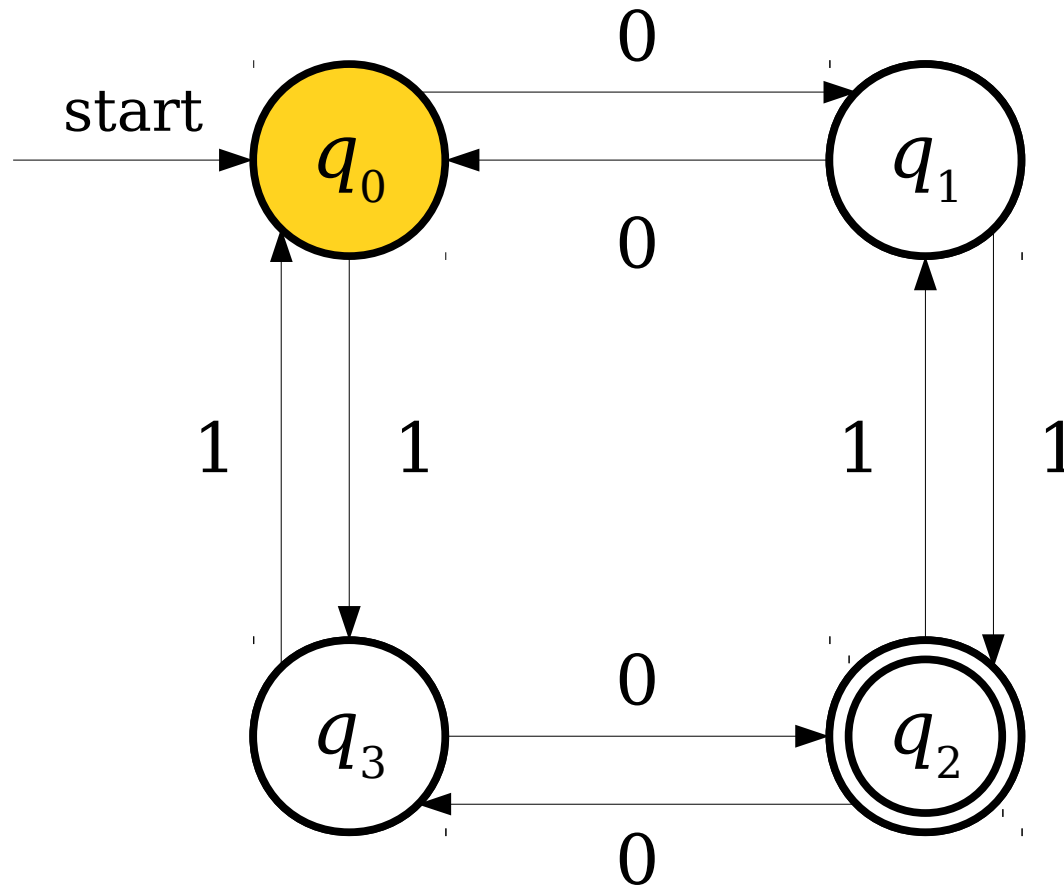

1 0 1 0 0 0

A Simple Finite Automaton

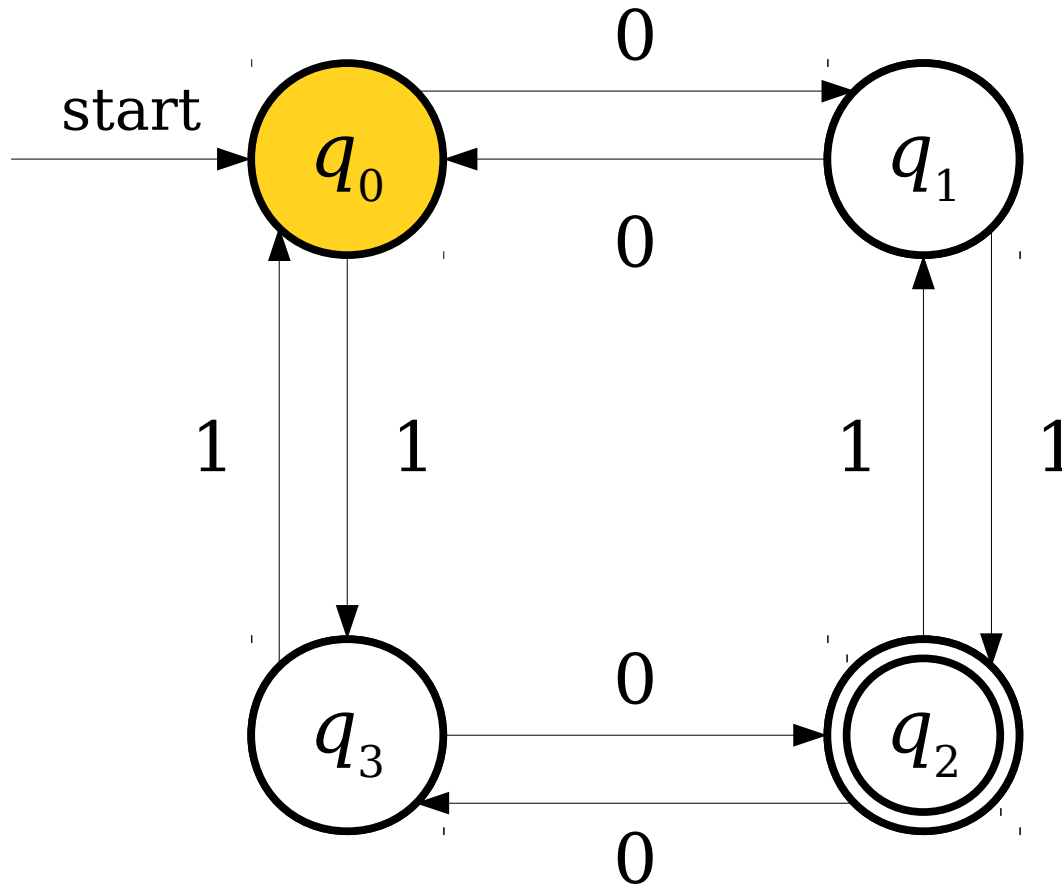

1 0 1 0 0 0

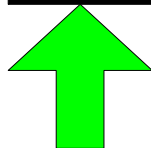

A Simple Finite Automaton

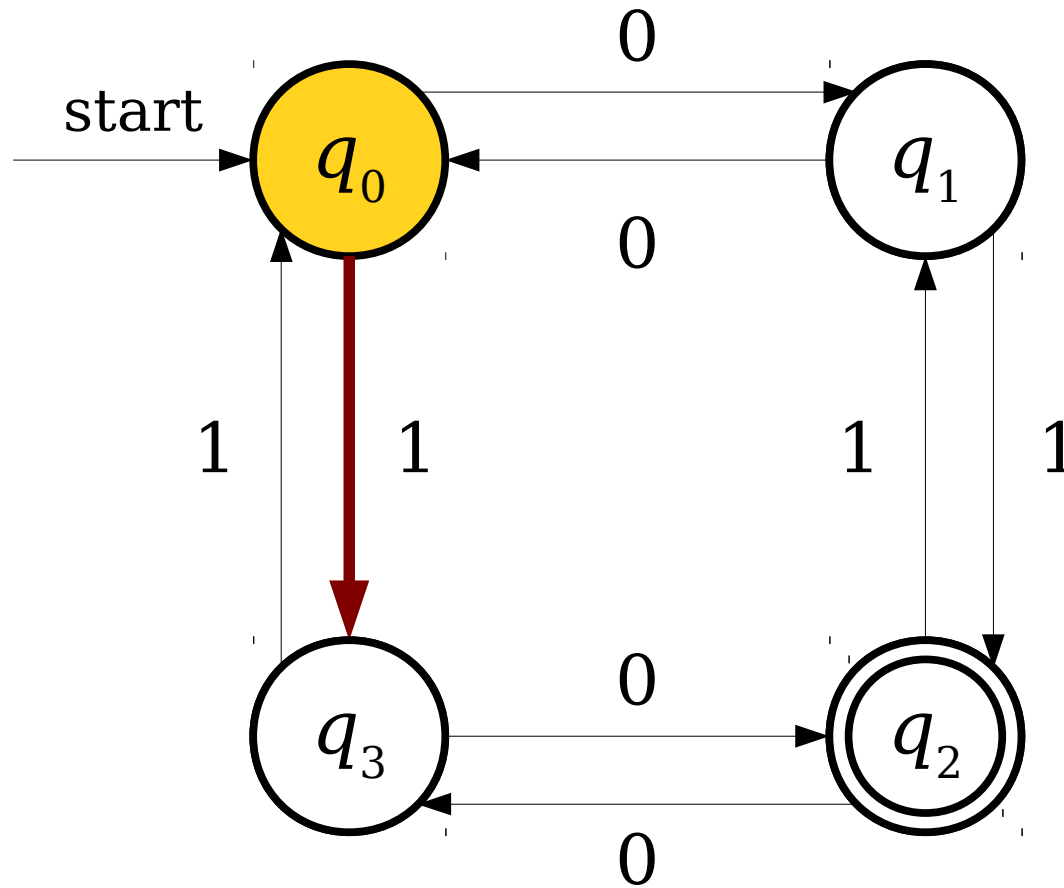

1 0 1 0 0 0

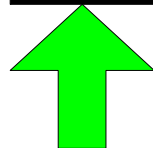

A Simple Finite Automaton

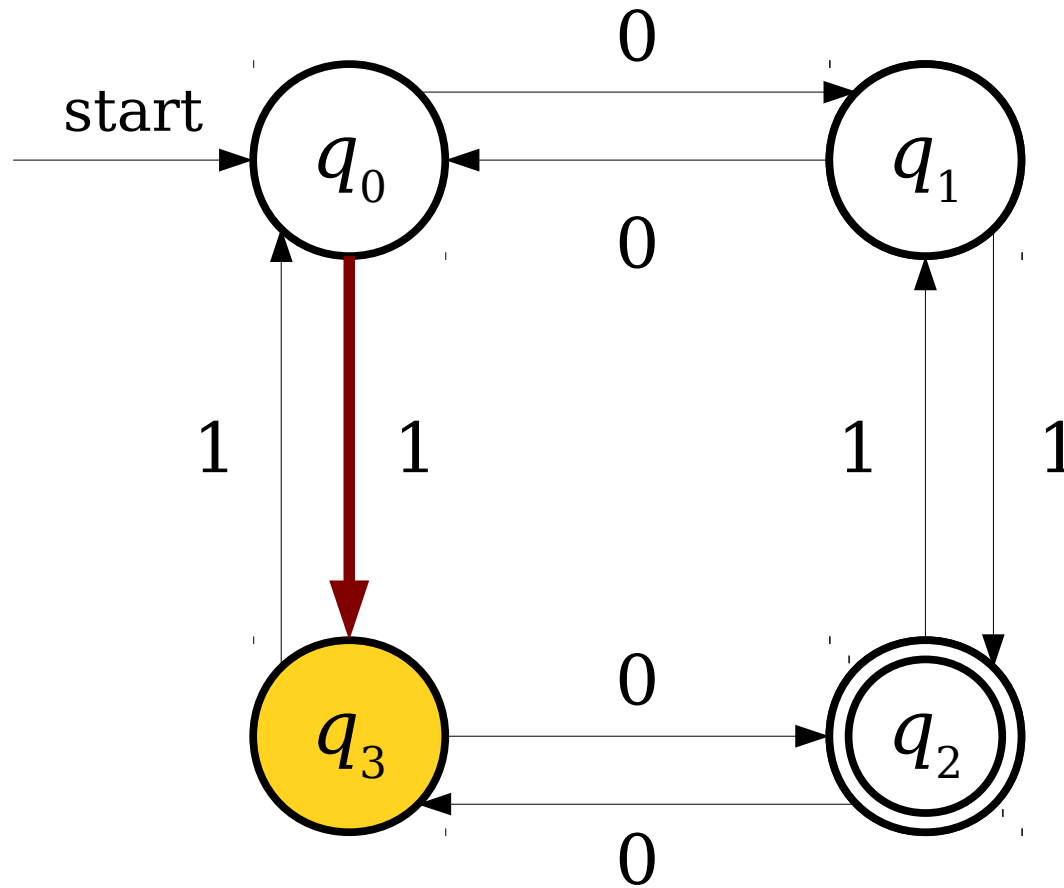

1 0 1 0 0 0

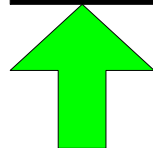

A Simple Finite Automaton

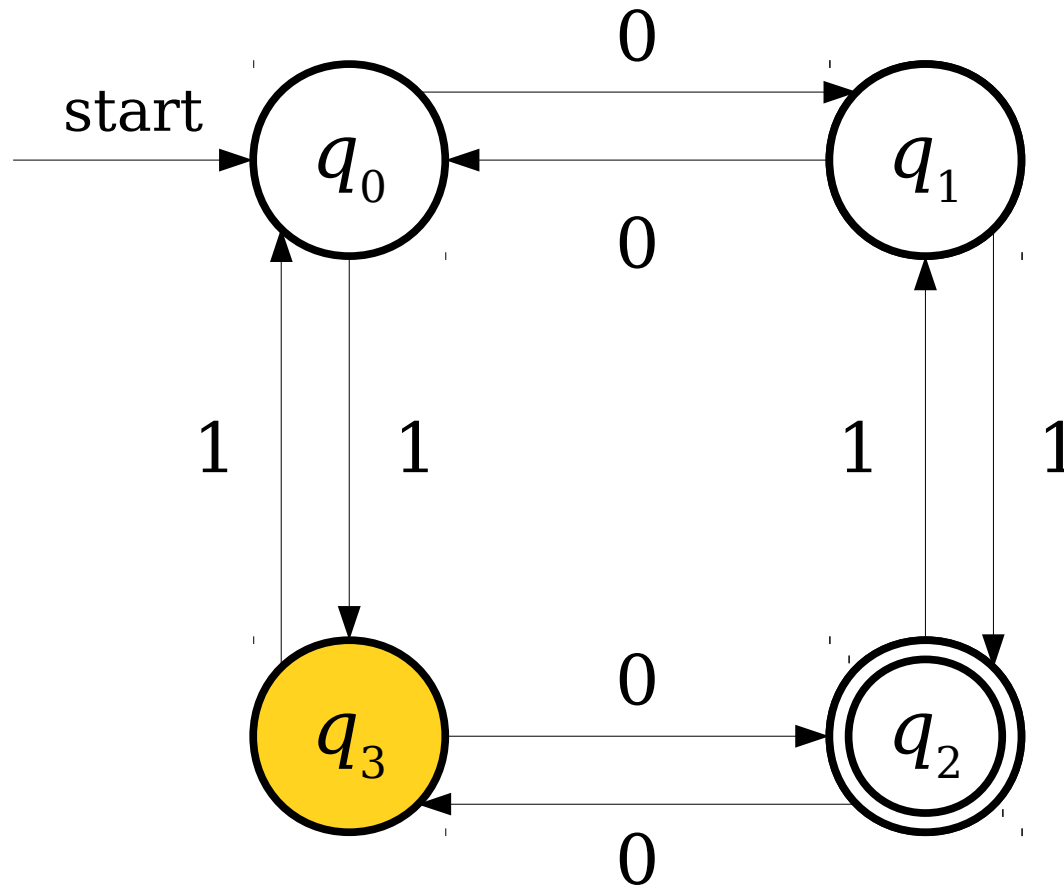

1 0 1 0 0 0

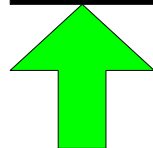

A Simple Finite Automaton

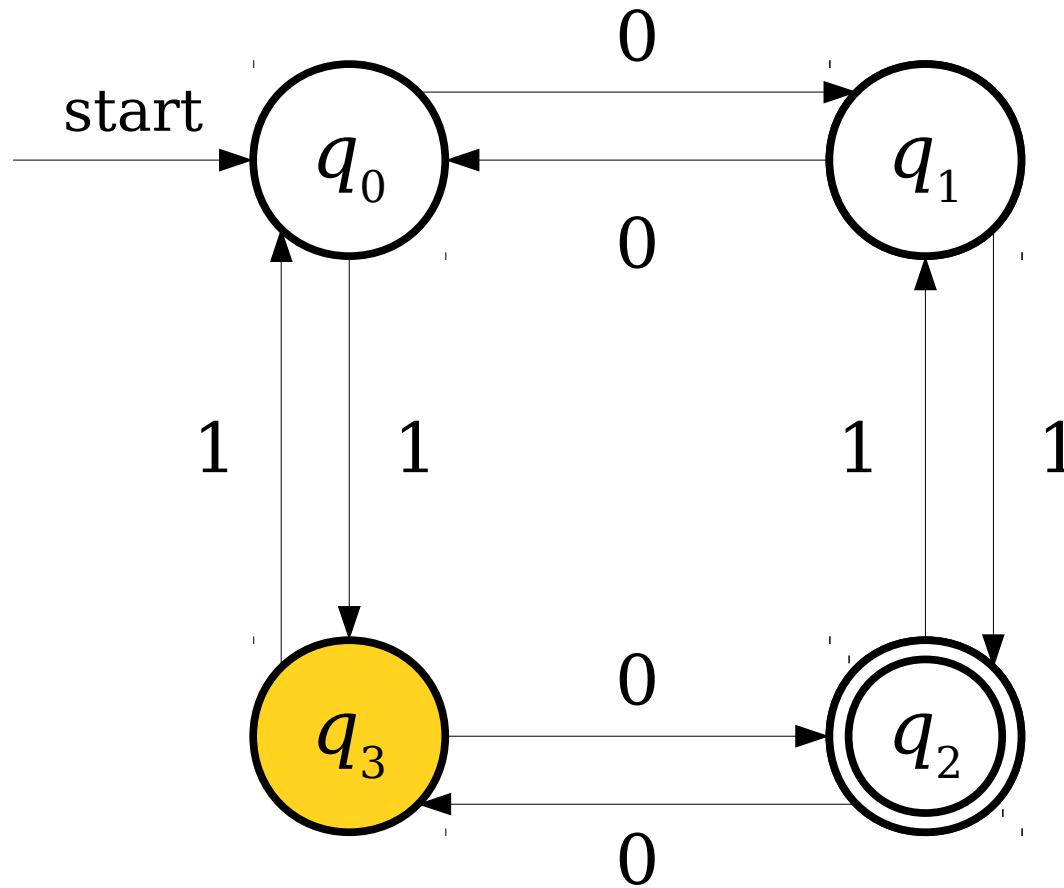

1 0 1 0 0 0

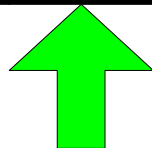

A Simple Finite Automaton

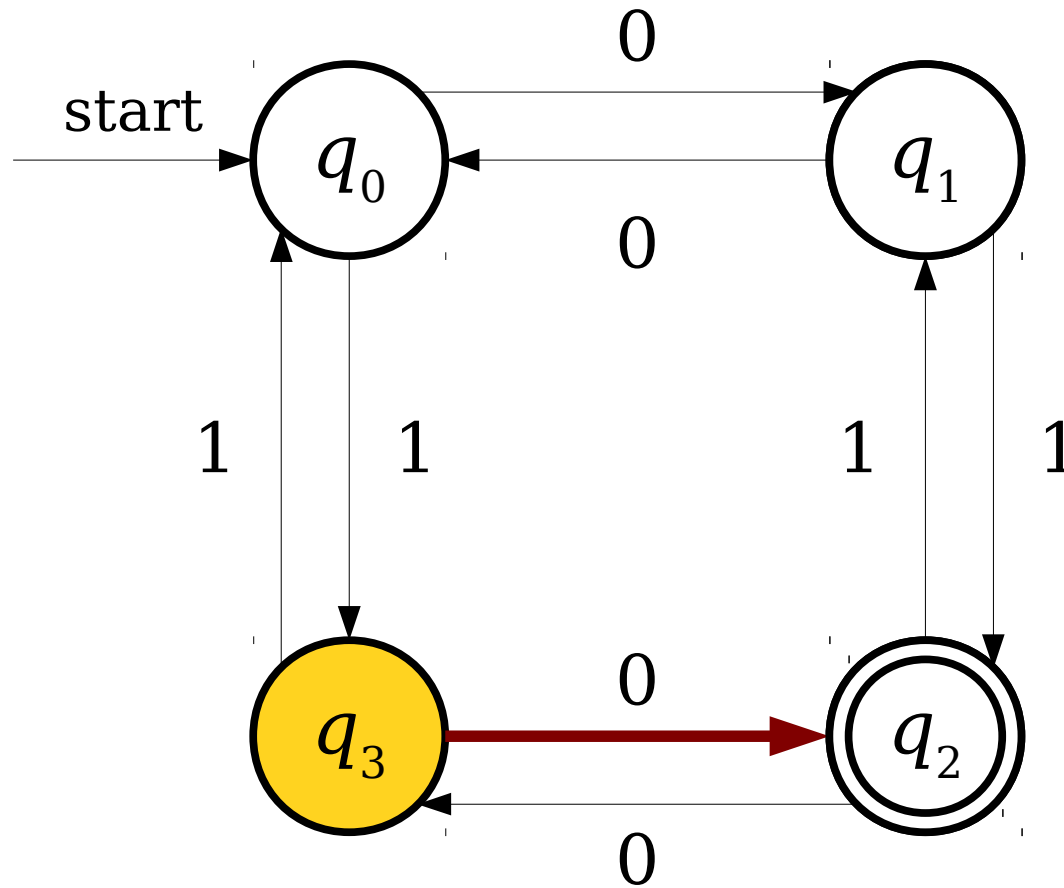

1 0 1 0 0 0

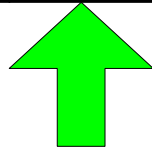

A Simple Finite Automaton

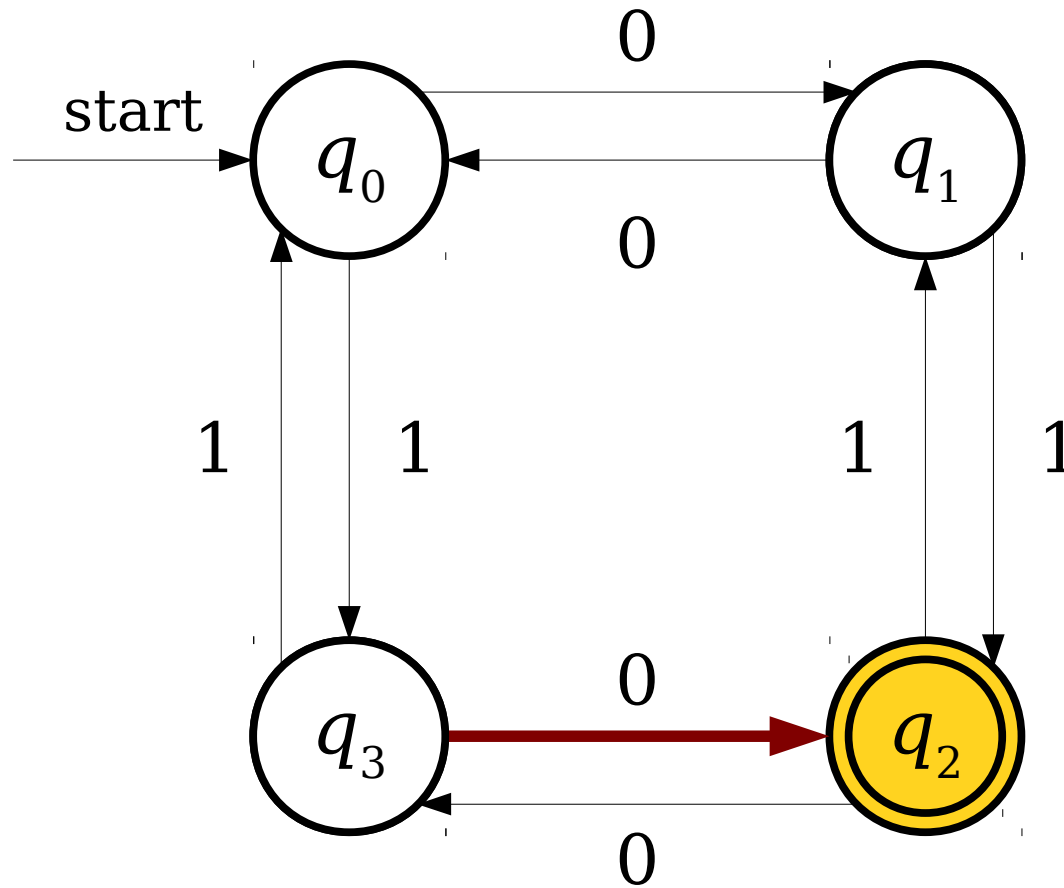

1 0 1 0 0 0

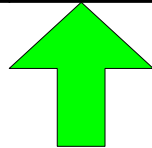

A Simple Finite Automaton

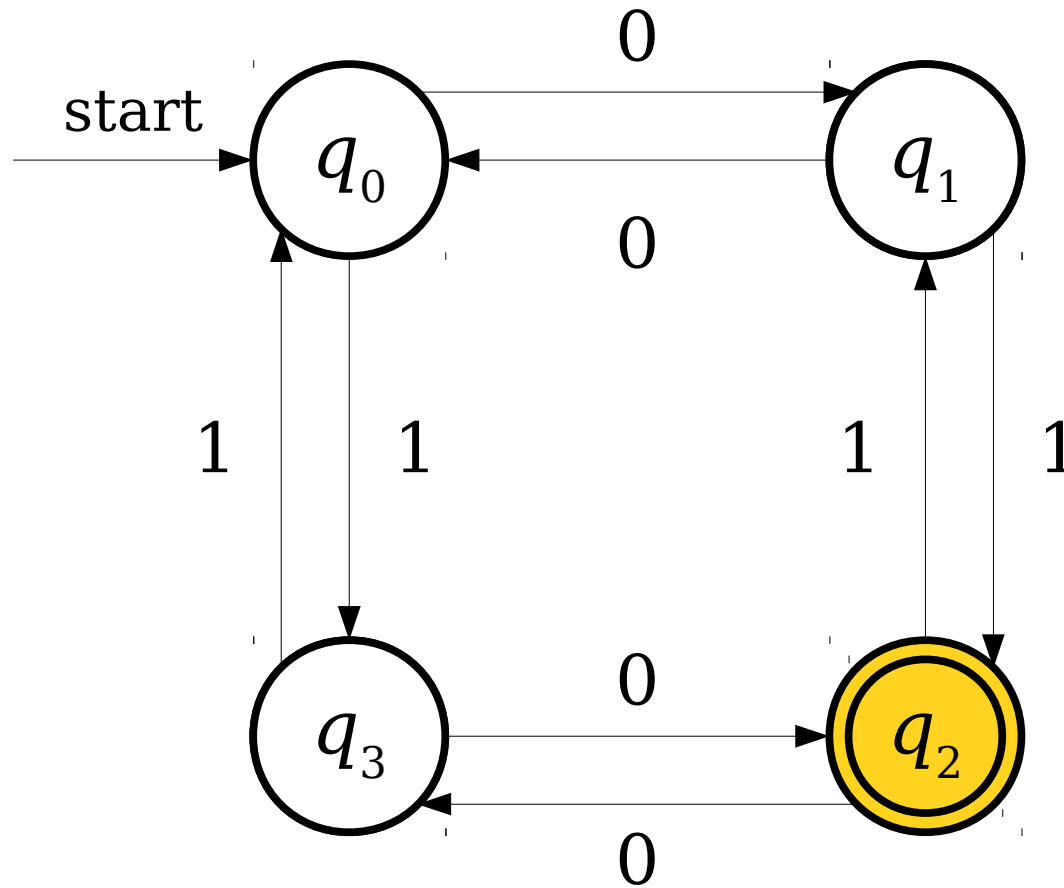

1 0 1 0 0 0

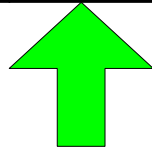

A Simple Finite Automaton

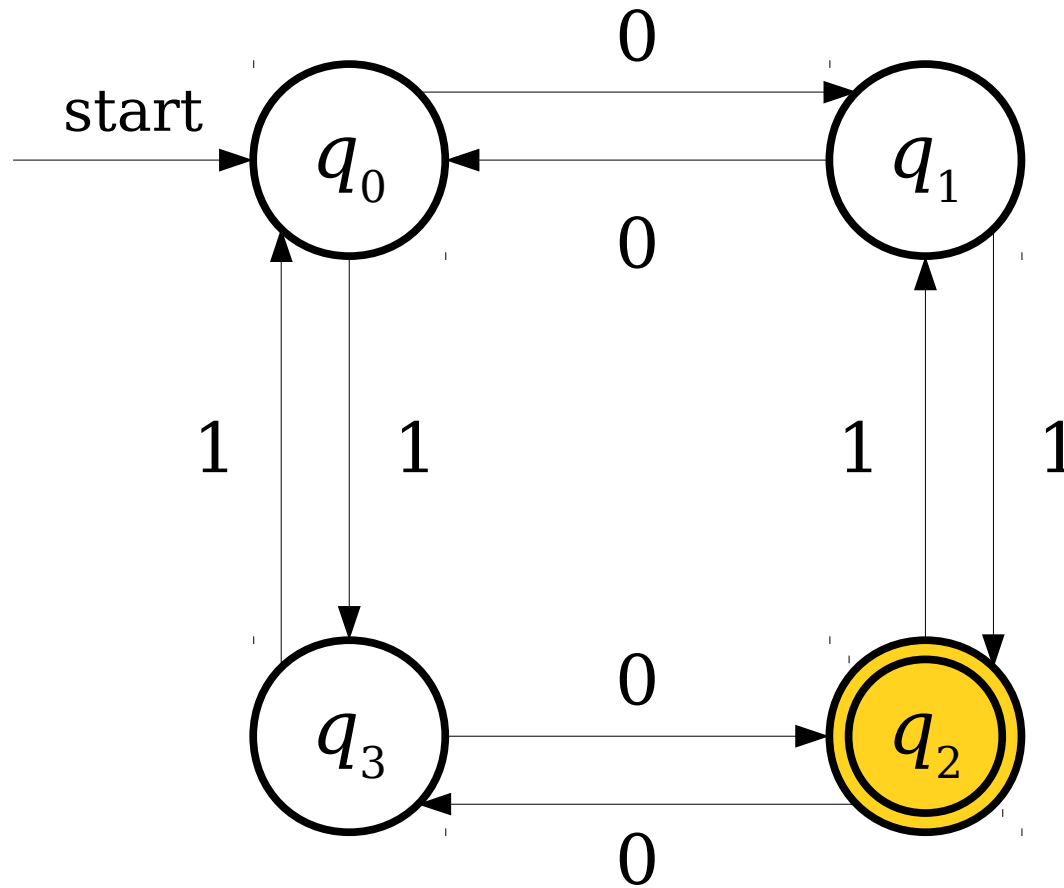

1 0 1 0 0 0

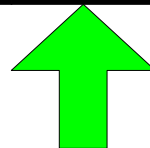

A Simple Finite Automaton

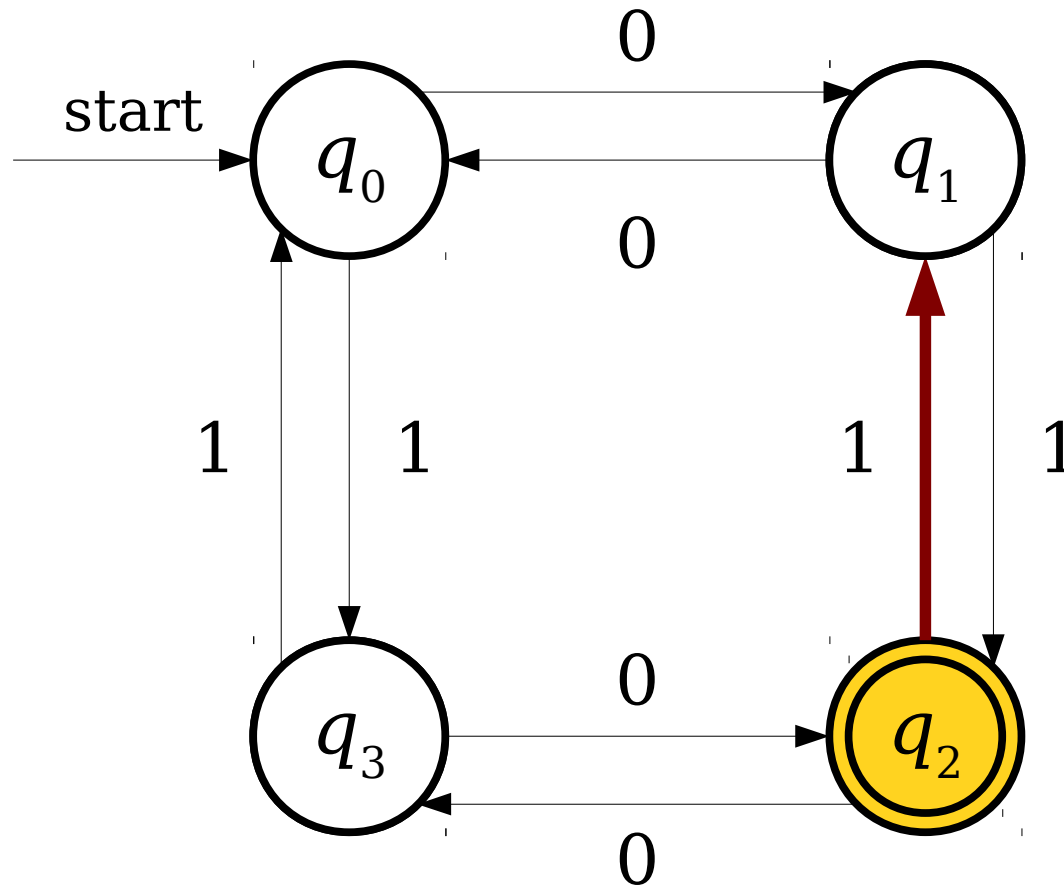

1 0 1 0 0 0

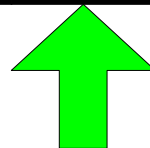

A Simple Finite Automaton

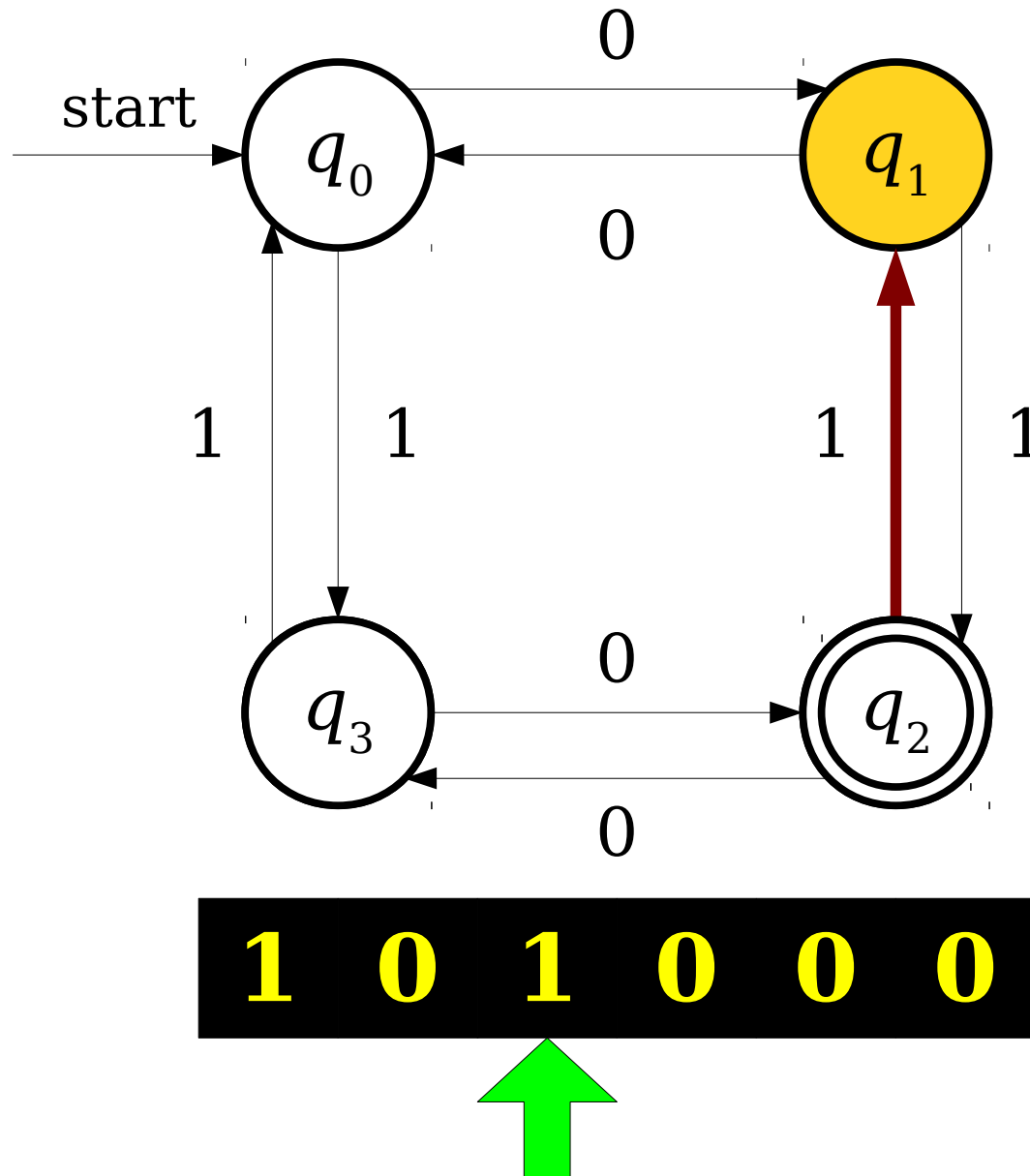

A Simple Finite Automaton

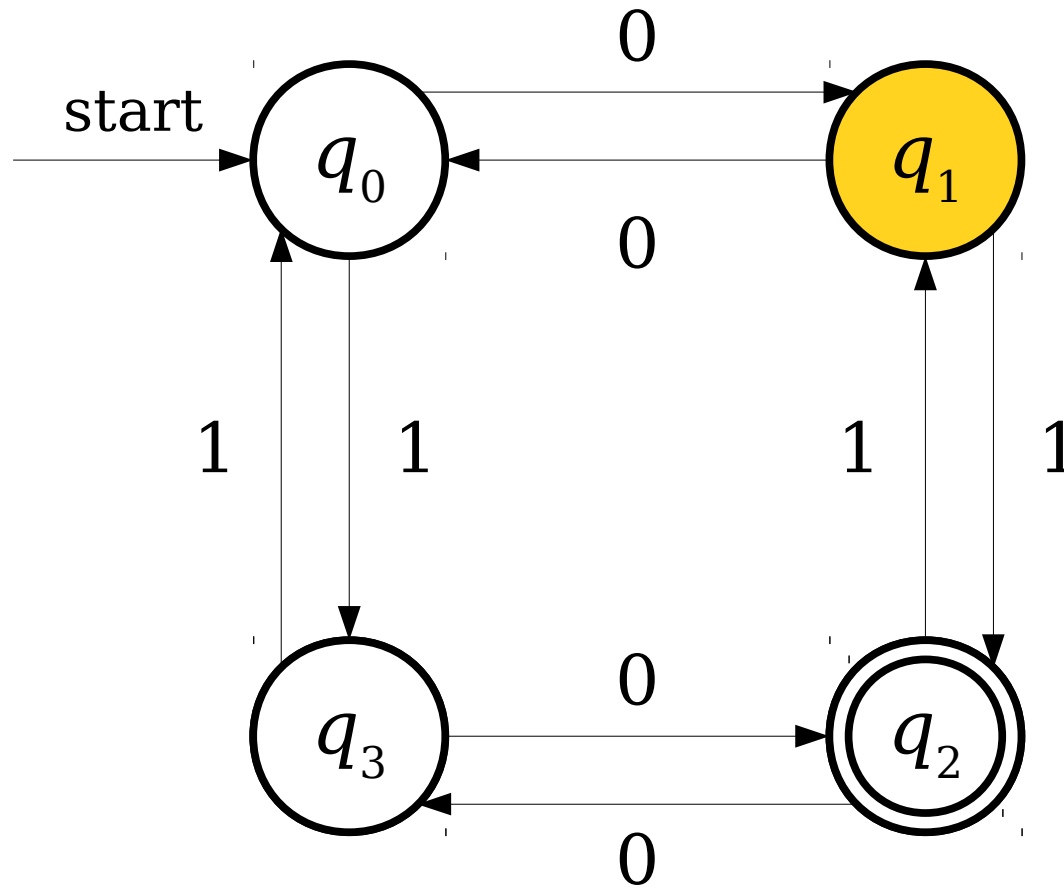

1 0 1 0 0 0

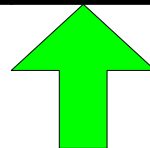

A Simple Finite Automaton

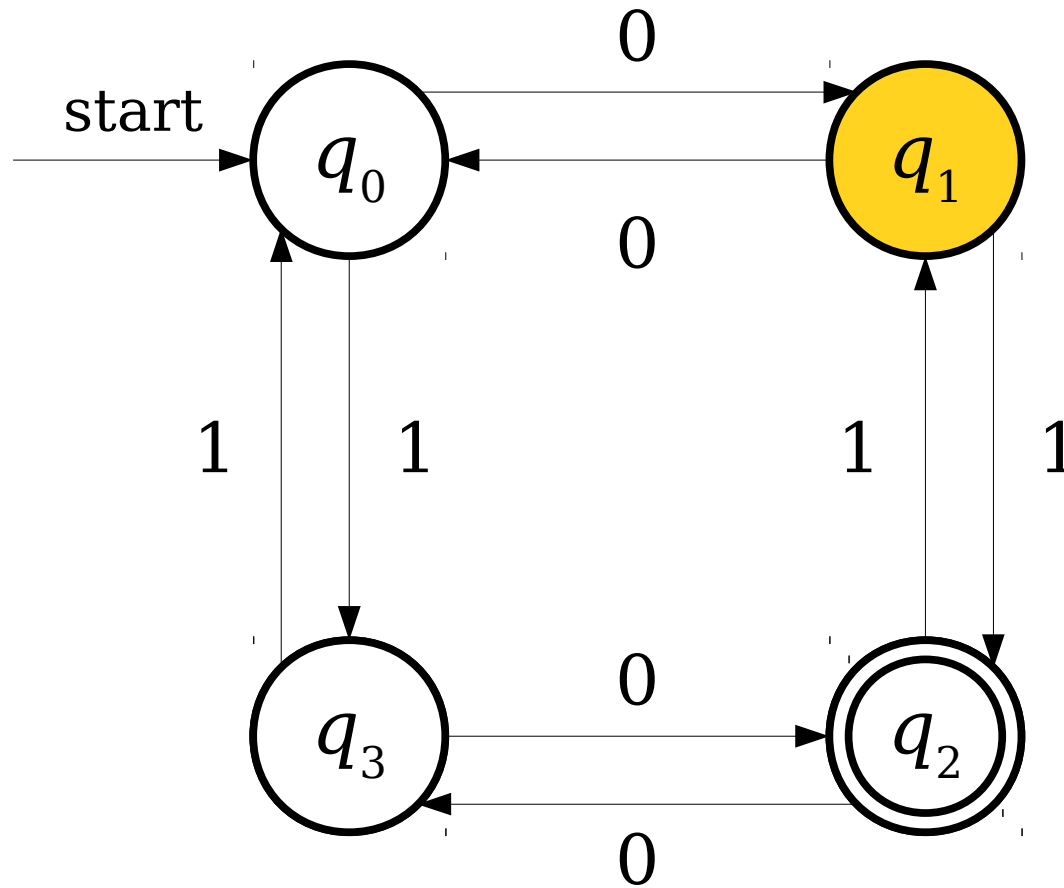

1 0 1 0 0 0

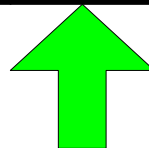

A Simple Finite Automaton

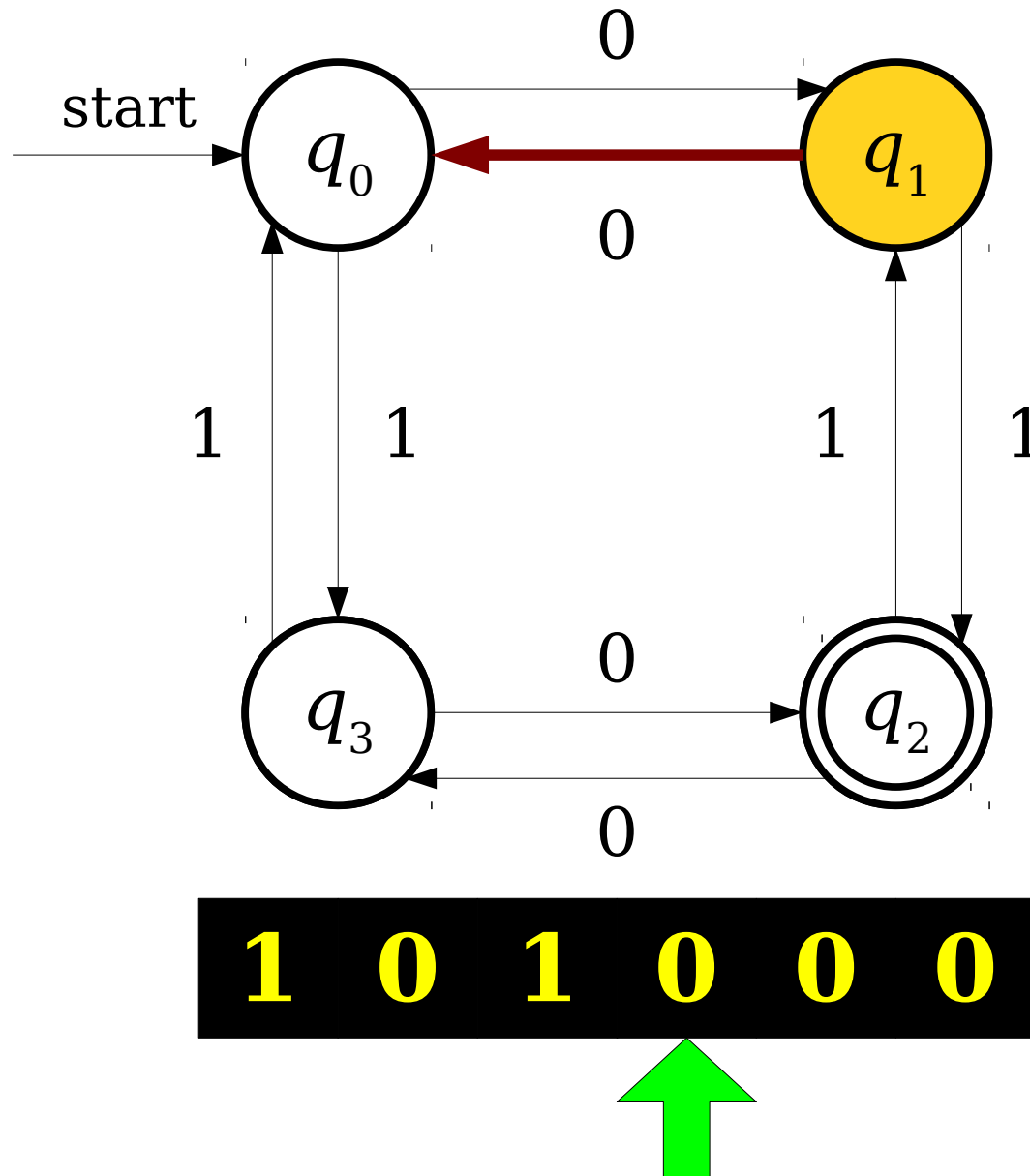

A Simple Finite Automaton

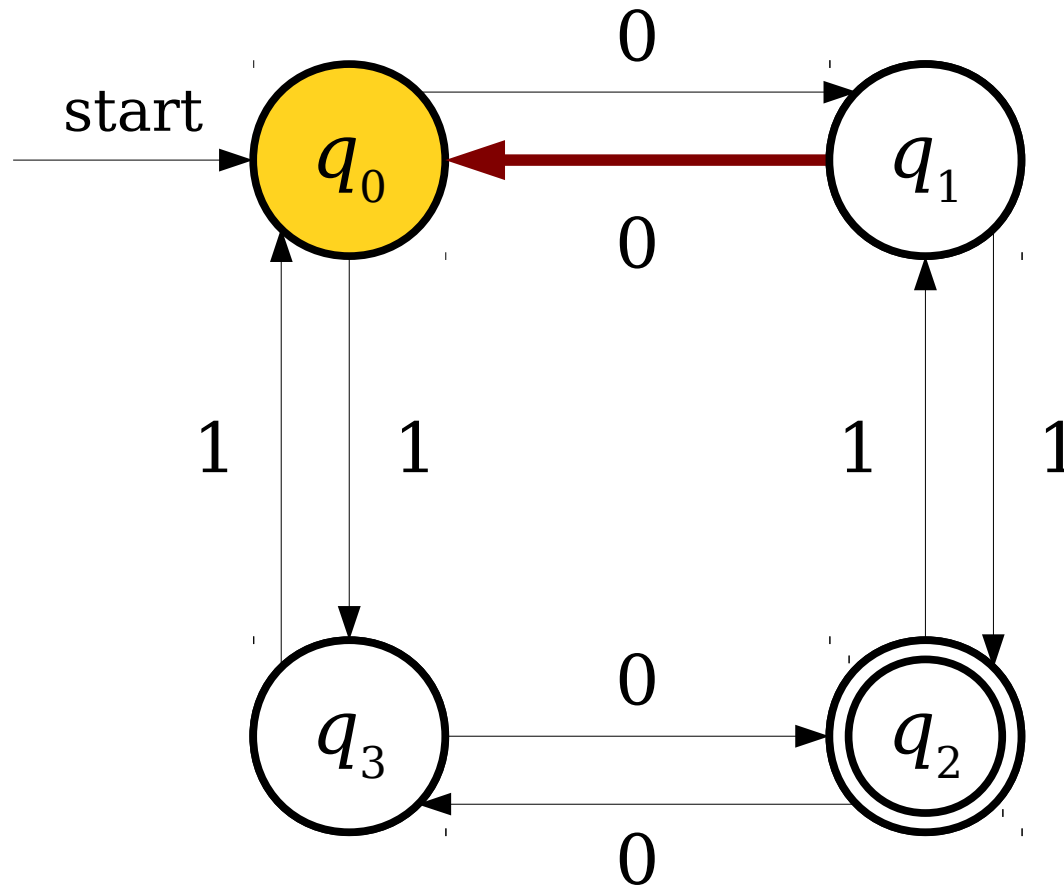

1 0 1 0 0 0

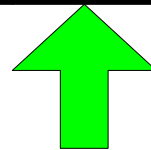

A Simple Finite Automaton

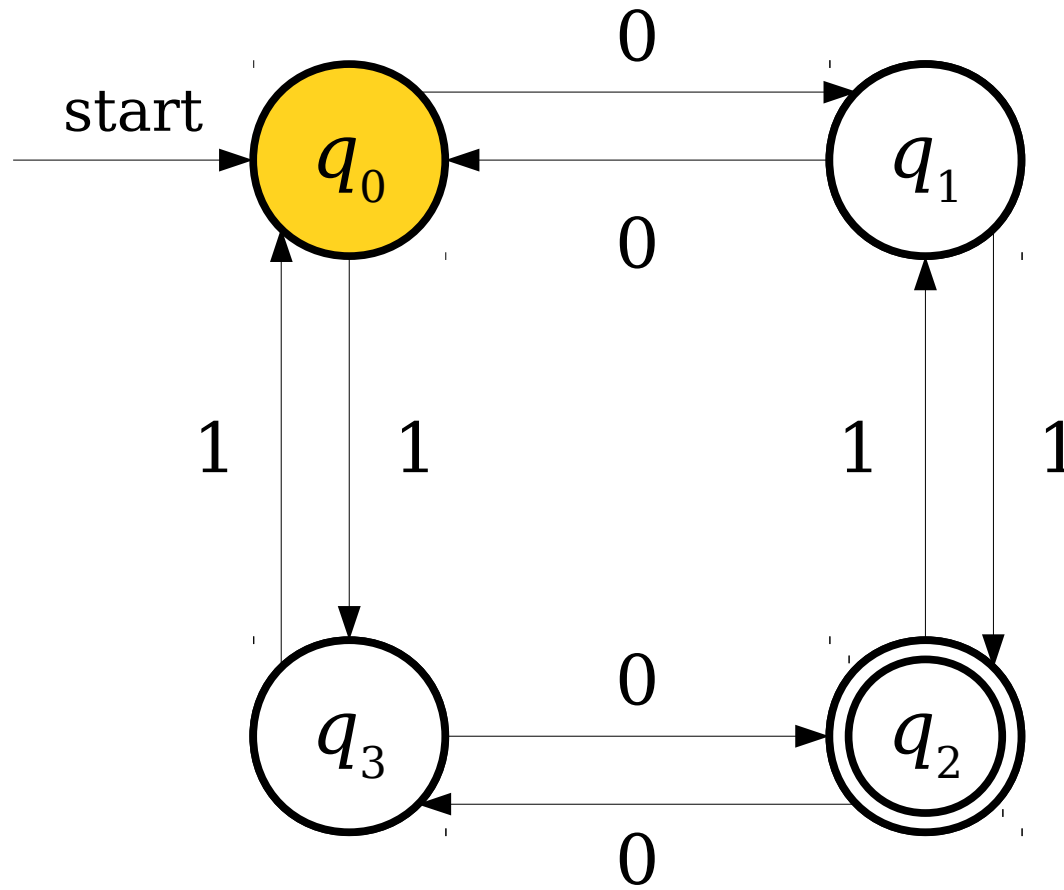

1 0 1 0 0 0

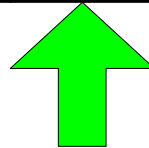

A Simple Finite Automaton

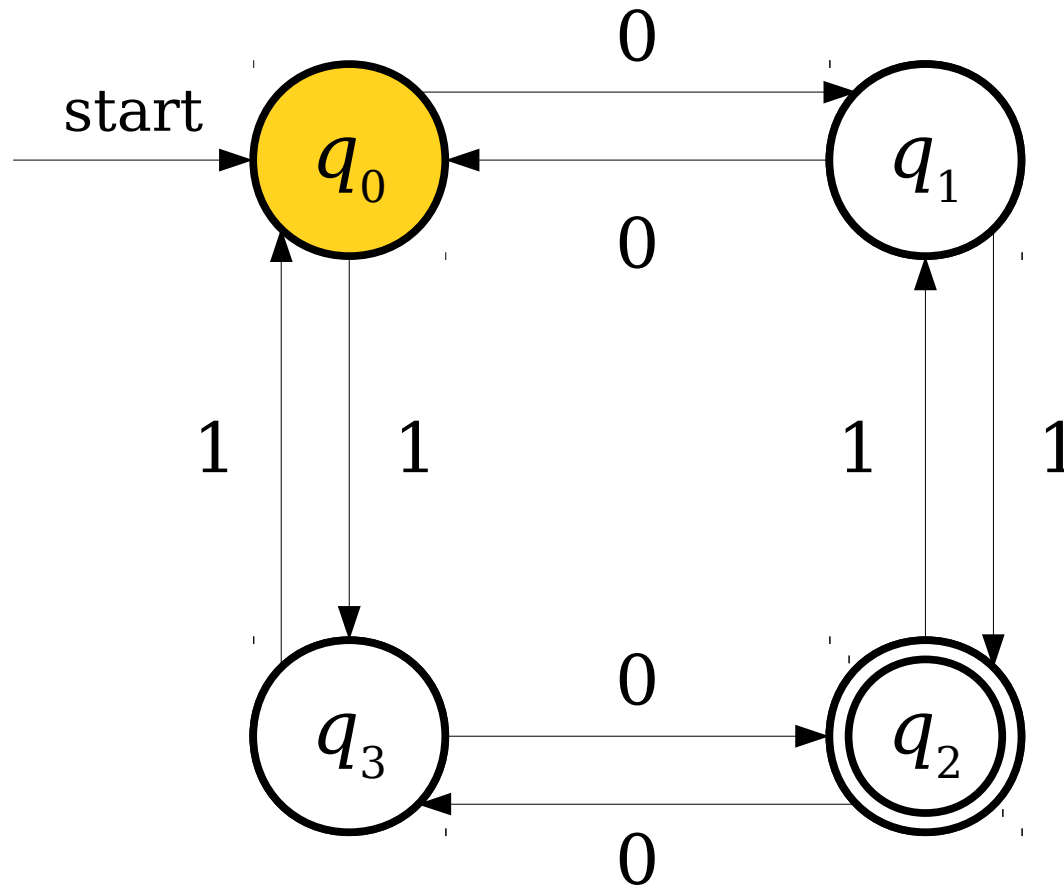

1 0 1 0 0 0



A Simple Finite Automaton

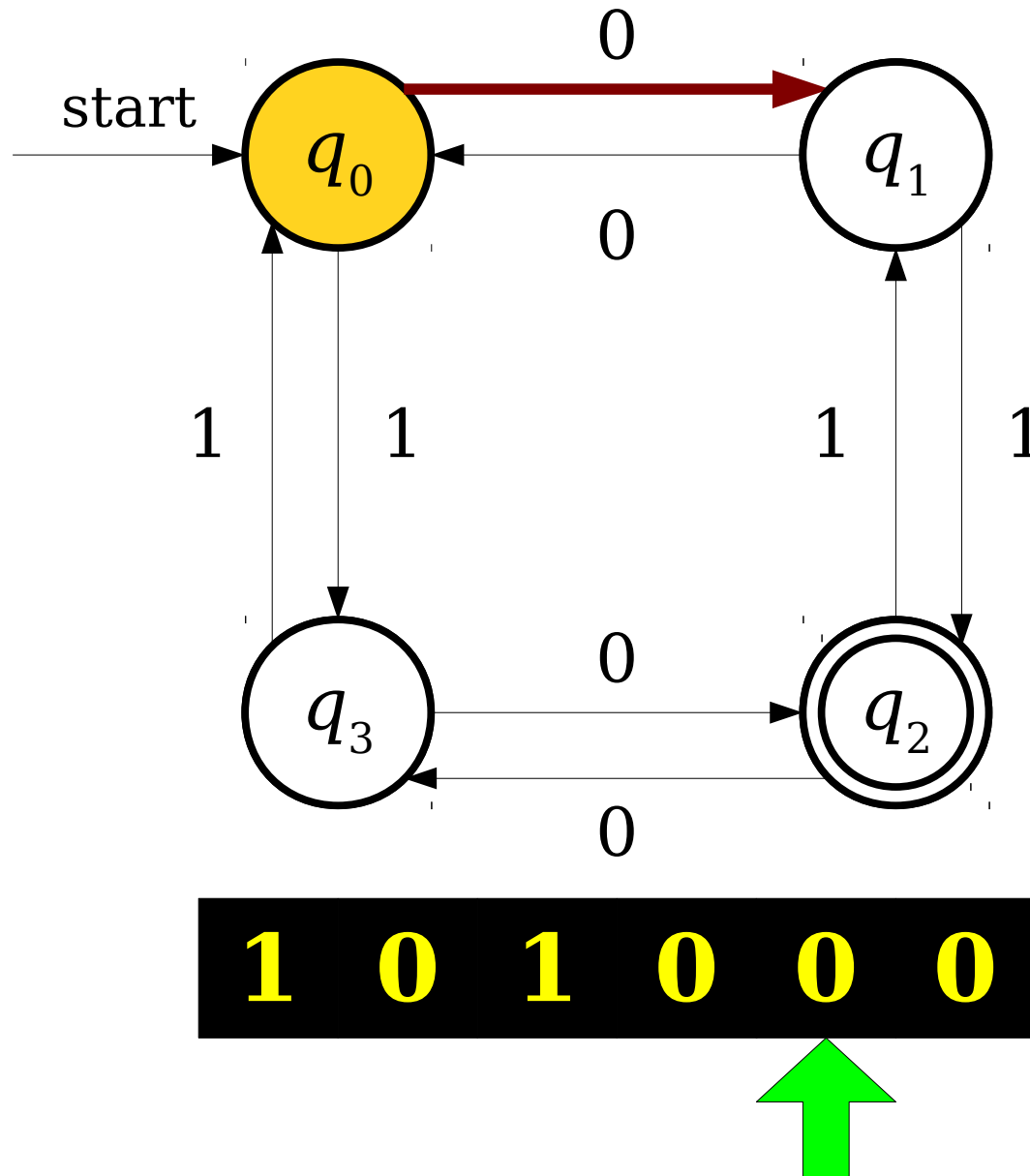

A Simple Finite Automaton

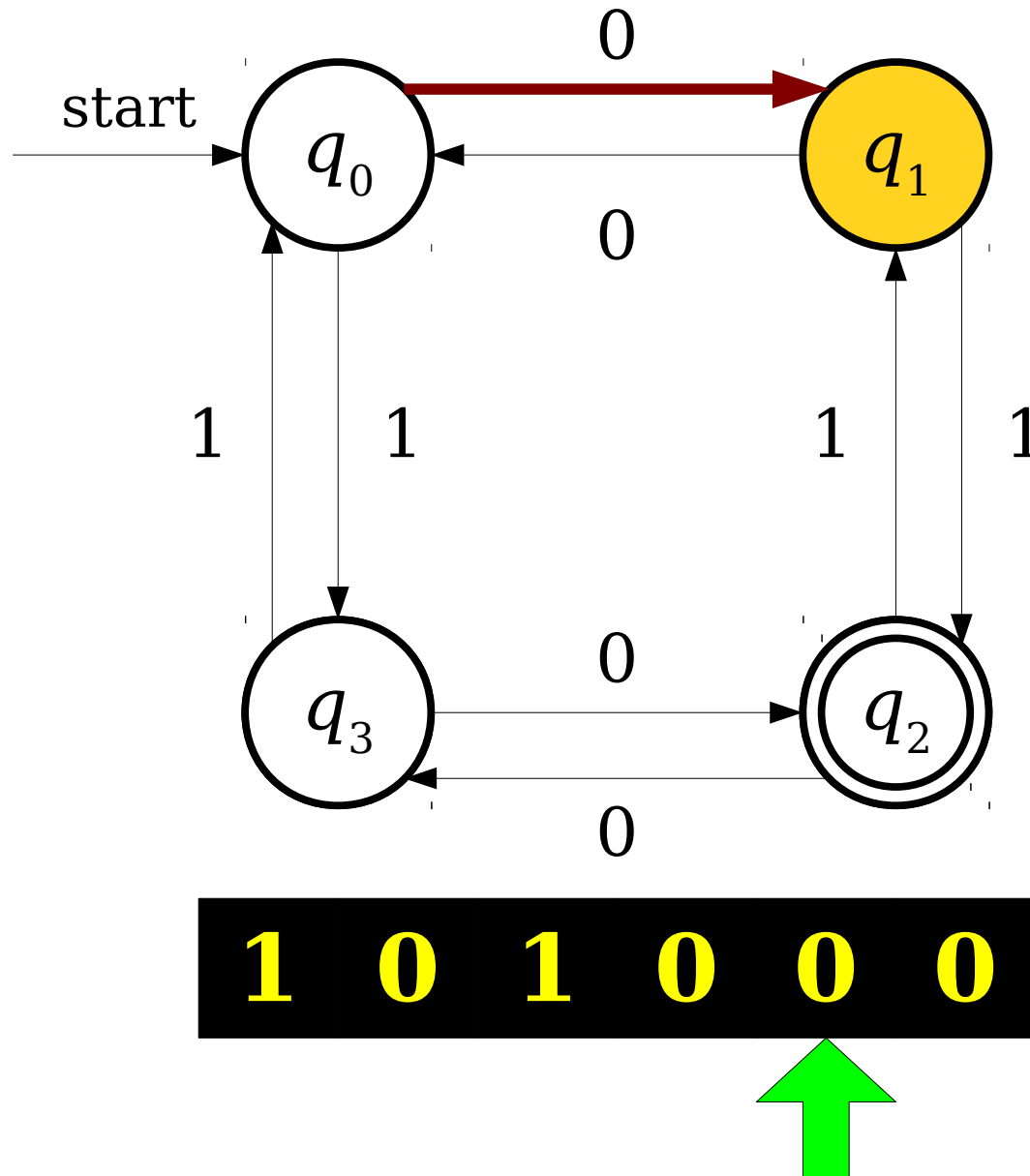

A Simple Finite Automaton

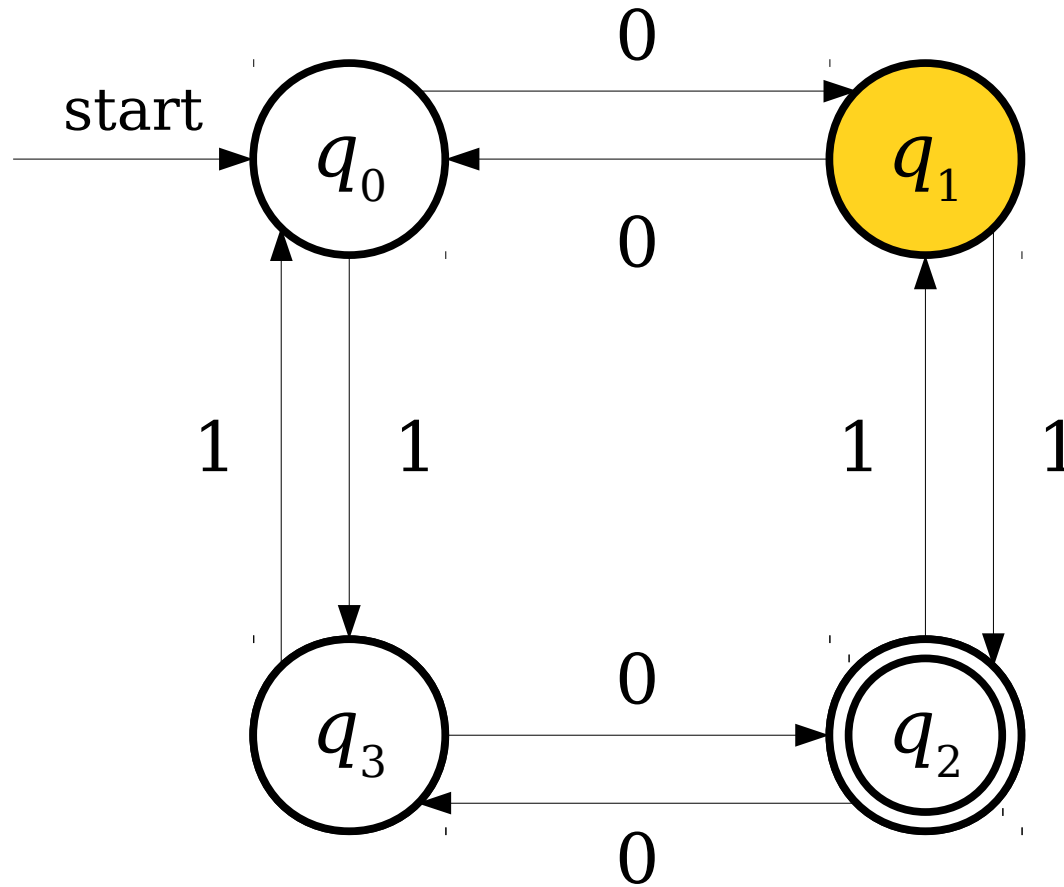

1 0 1 0 0 0



A Simple Finite Automaton

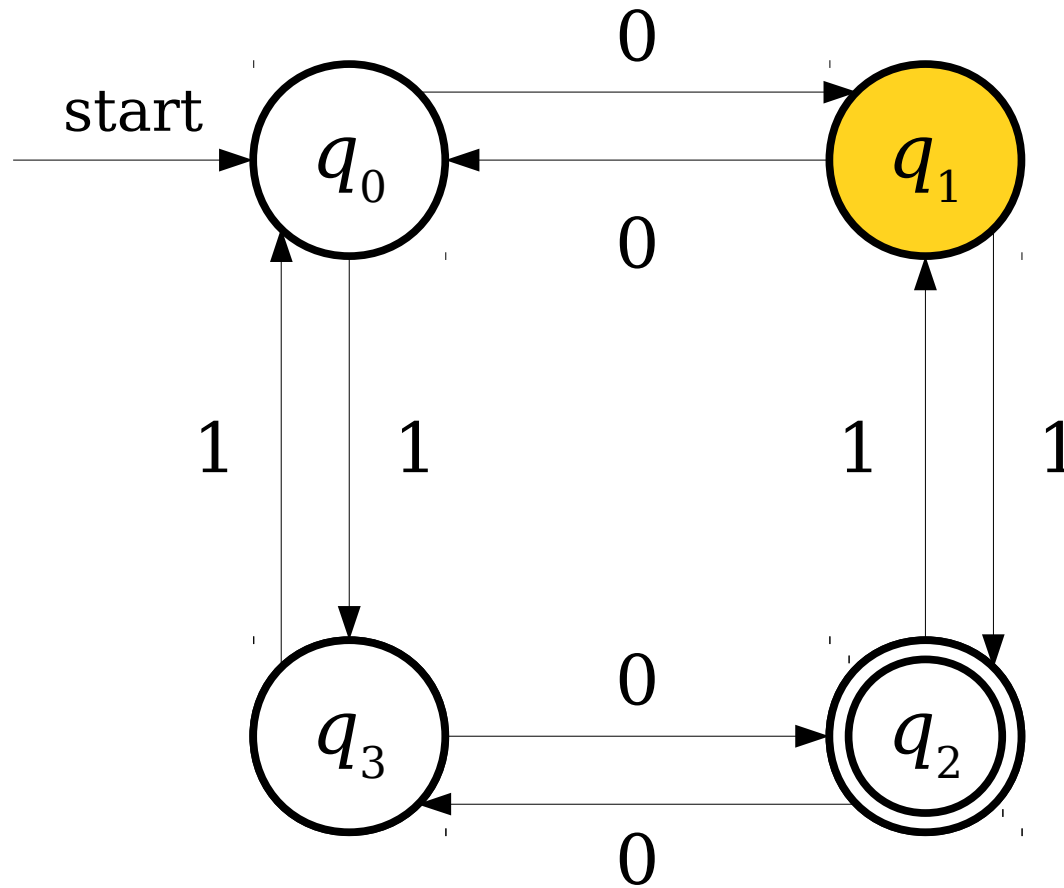

1 0 1 0 0 0



A Simple Finite Automaton

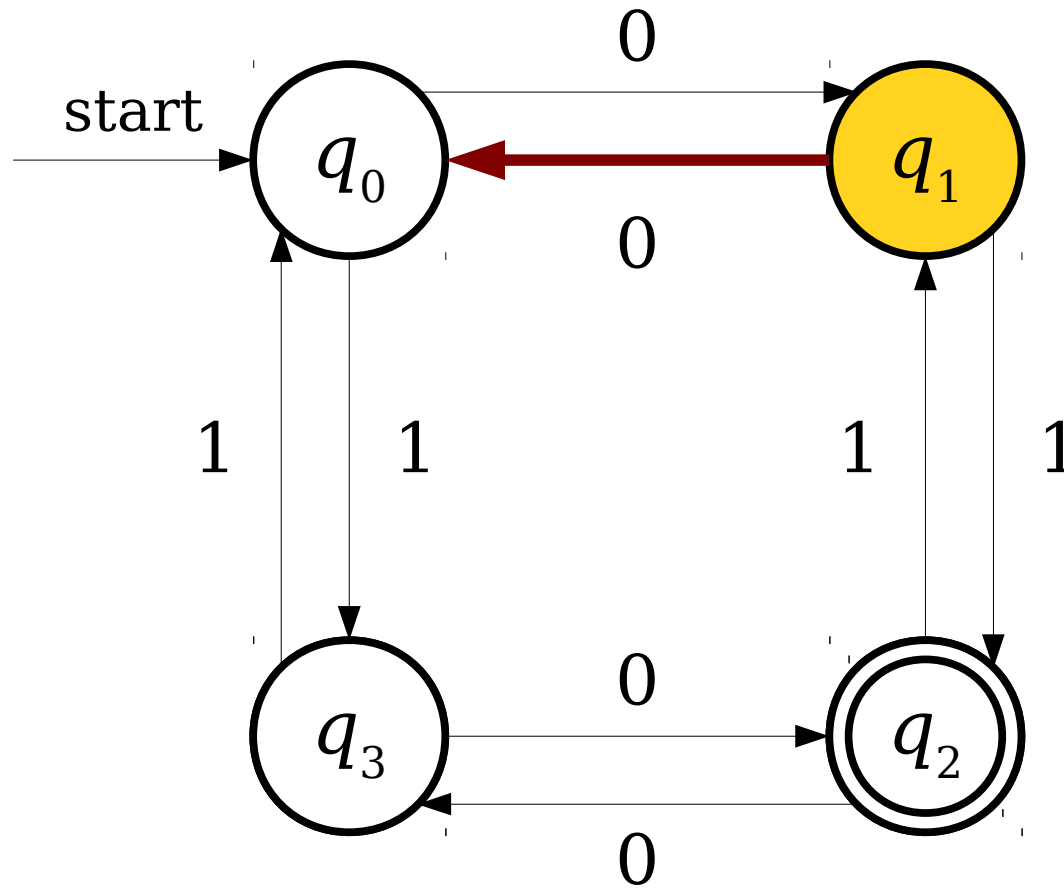

1 0 1 0 0 0

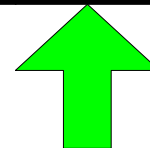

A Simple Finite Automaton

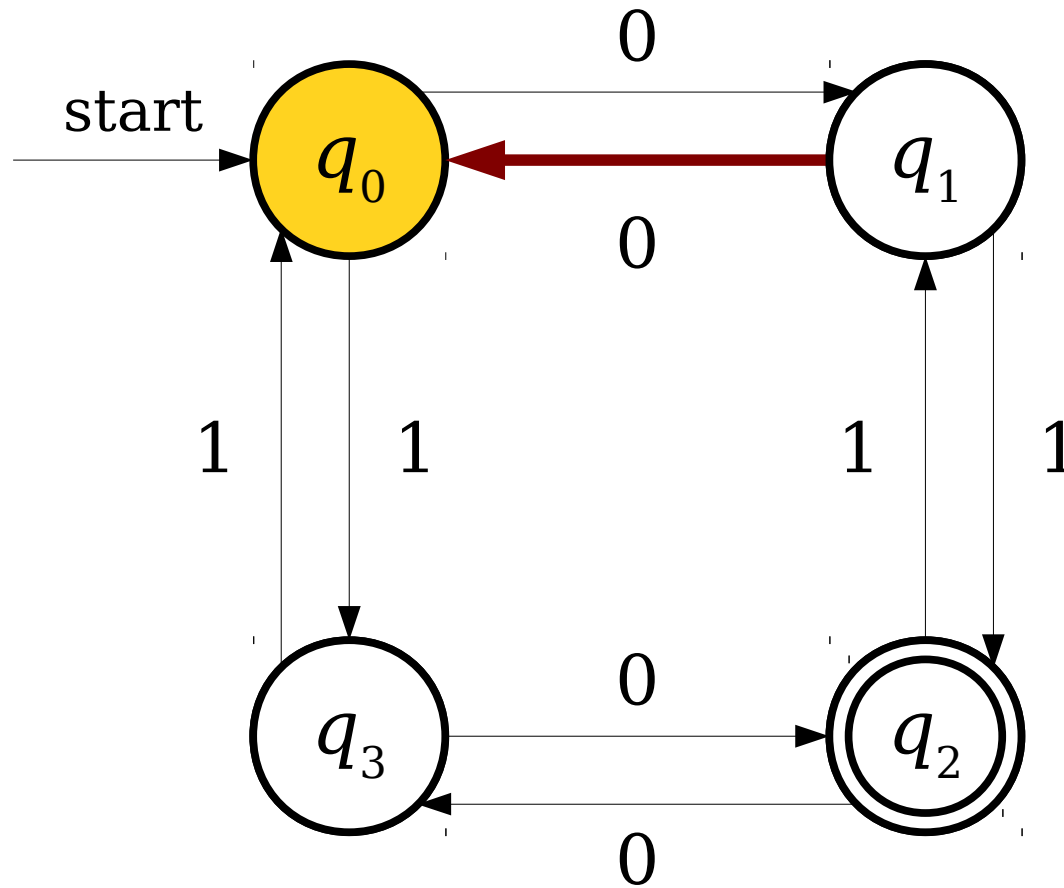

1 0 1 0 0 0

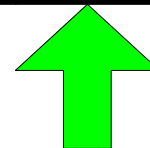

A Simple Finite Automaton

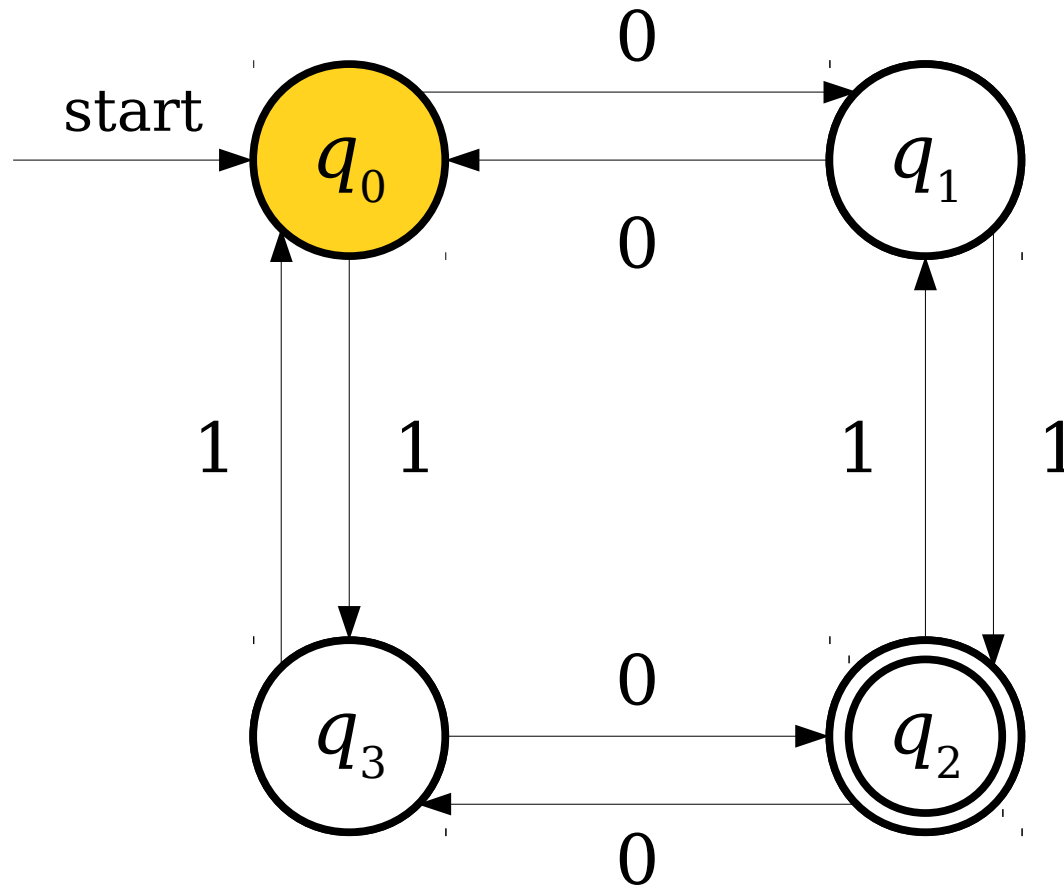

1 0 1 0 0 0



A Simple Finite Automaton

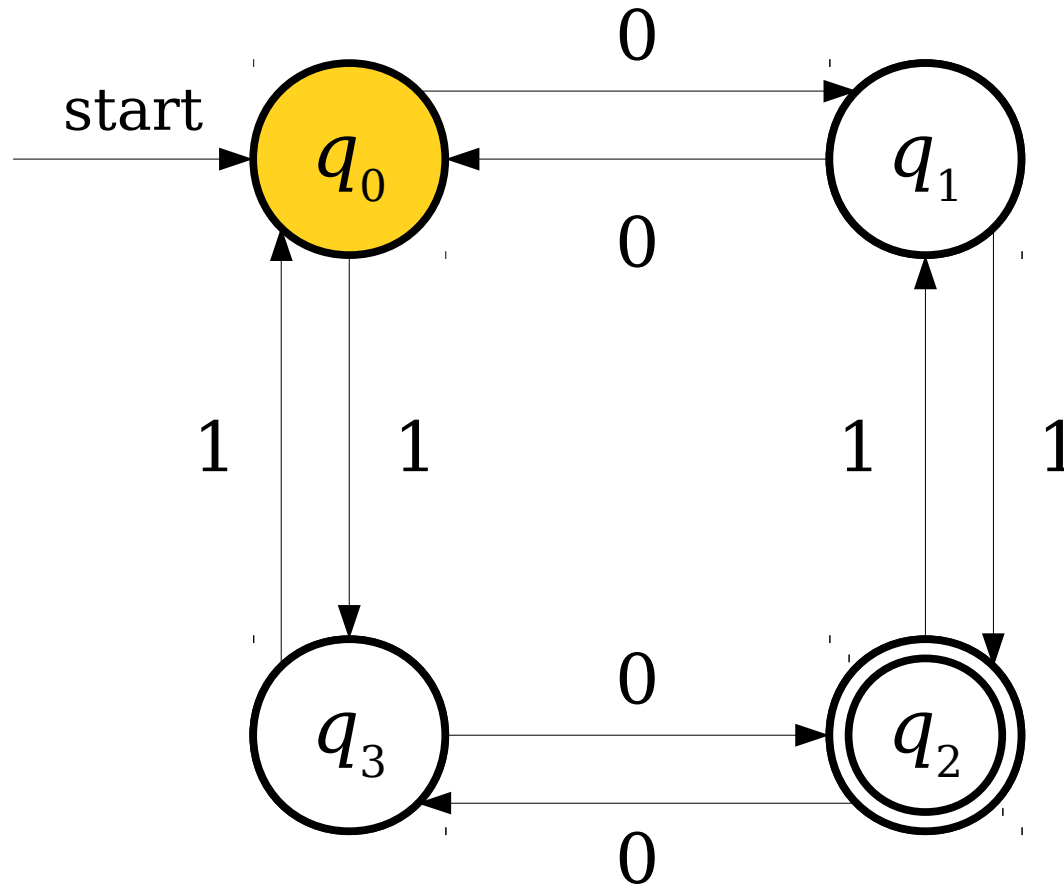

1 0 1 0 0 0

A Simple Finite Automaton

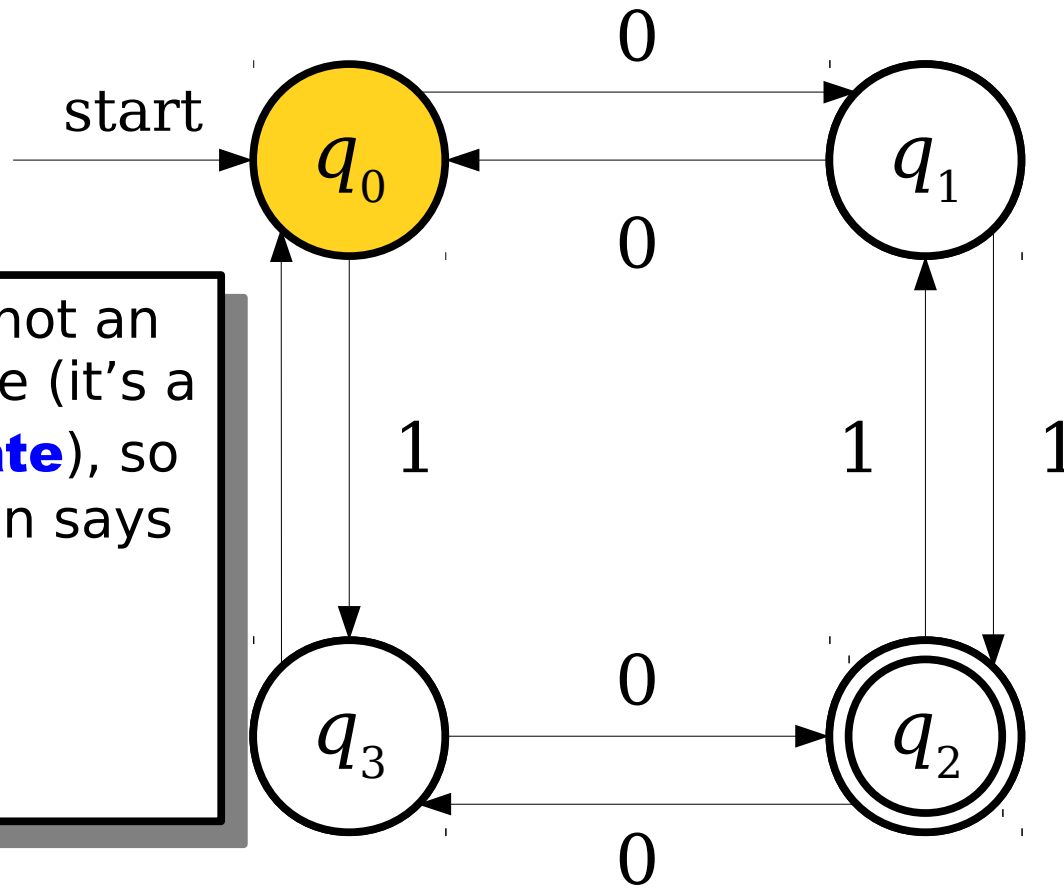

This state is not an accepting state (it's a **rejecting state**), so the automaton says "no."

1 0 1 0 0 0

A Simple Finite Automaton

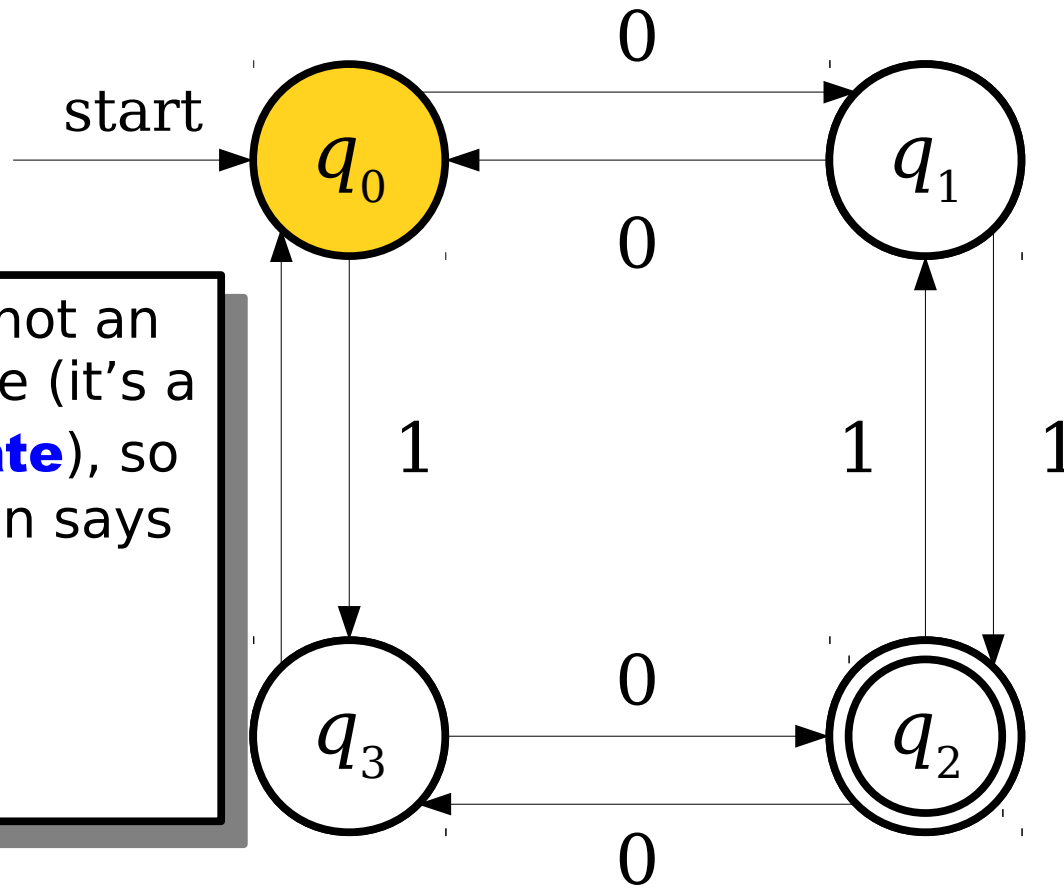

This state is not an accepting state (it's a **rejecting state**), so the automaton says "no."

1 0 1 0 0 0

A Simple Finite Automaton

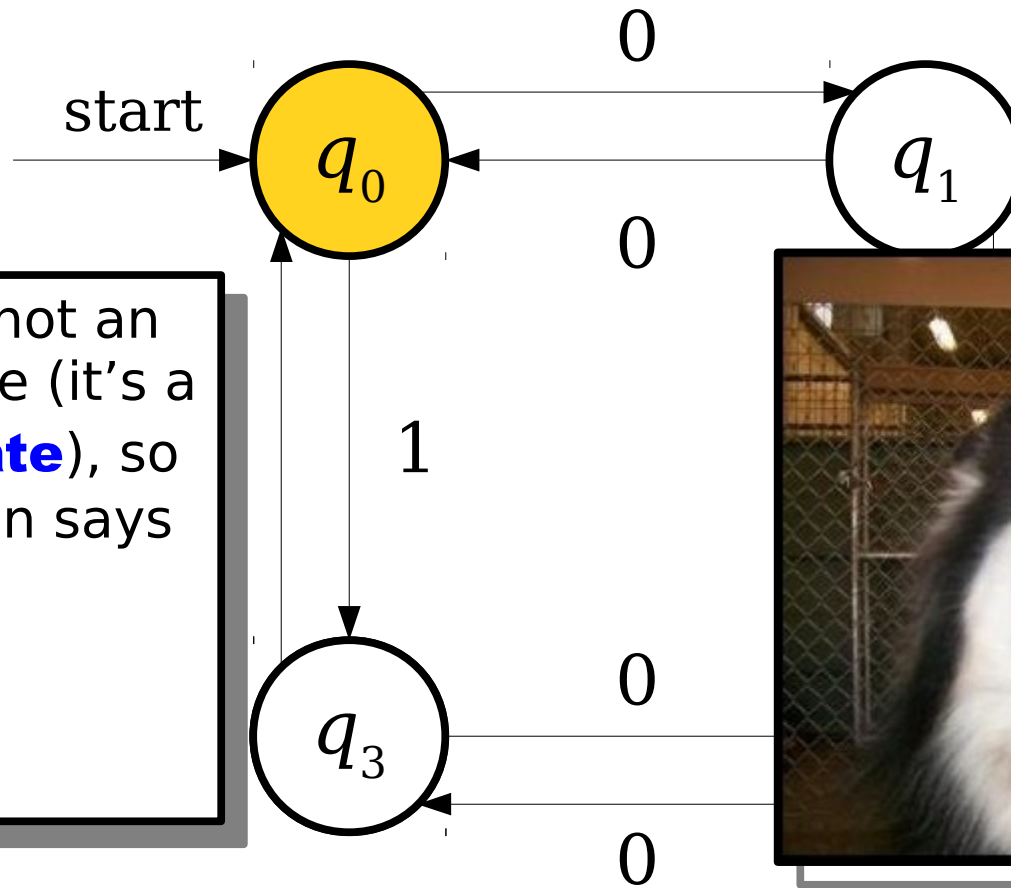

This state is not an accepting state (it's a **rejecting state**), so the automaton says "no."



1 0 1 0 0 0

A Simple Finite Automaton

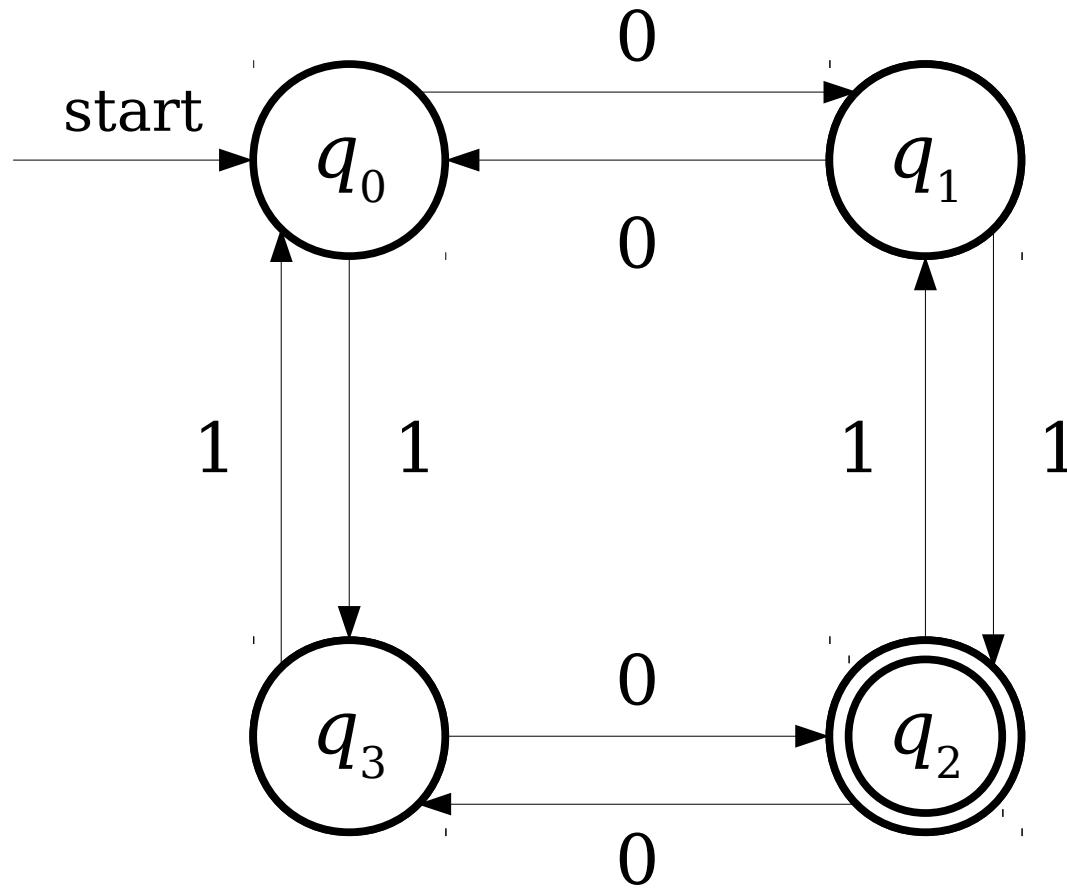

A Simple Finite Automaton

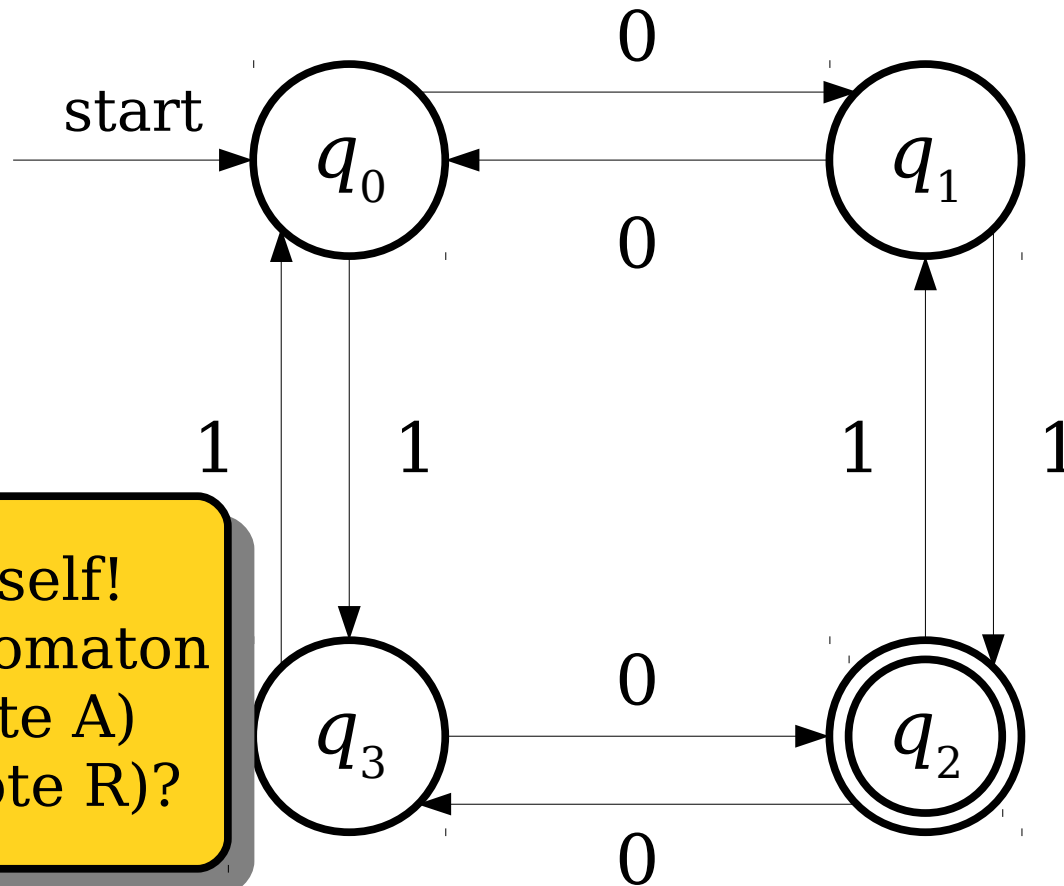

Try it yourself!
Does this automaton
accept (vote A)
or *reject* (vote R)?

1 1 0 1 1 1 0 0

Answer at [PollEv.com/cs103](https://www.pollEv.com/cs103) or
text **CS103** to **22333** once to join, then **A or R**.

The Story So Far

- A ***finite automaton*** is a collection of ***states*** joined by ***transitions***.
- Some state is designated as the ***start state***.
- Some states are designated as ***accepting states***.
- The automaton processes a string by beginning in the start state and following the indicated transitions.
- If the automaton ends in an accepting state, it ***accepts*** the input.
- Otherwise, the automaton ***rejects*** the input.

Just Passing Through

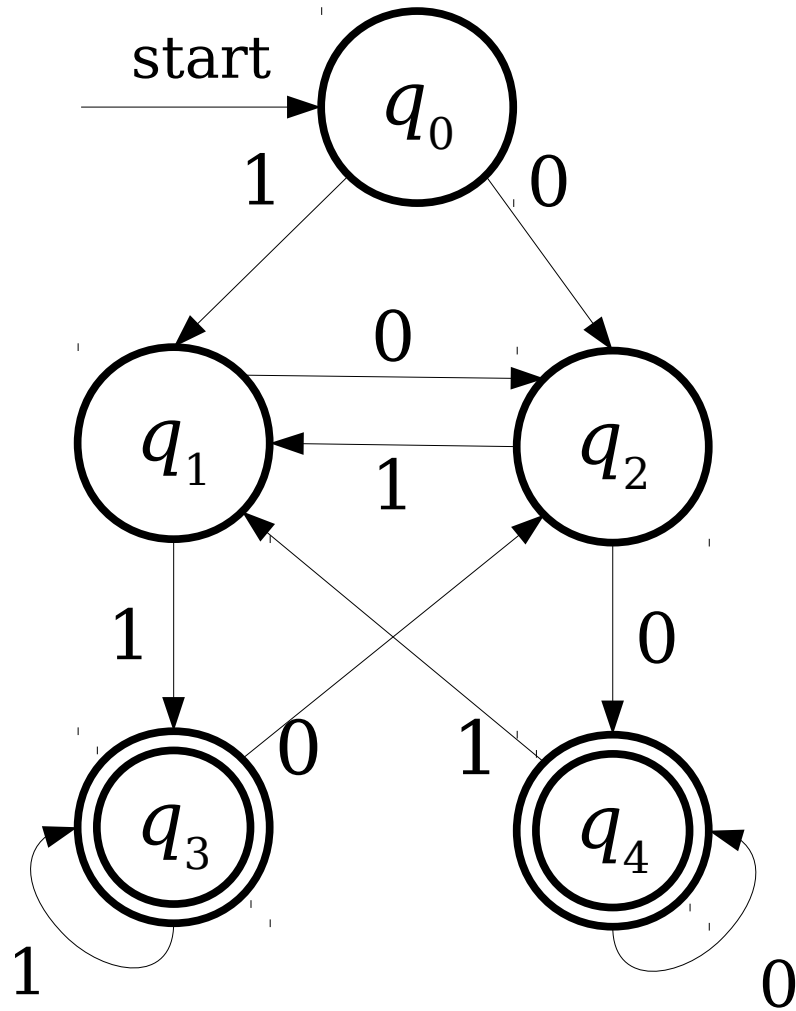

Just Passing Through

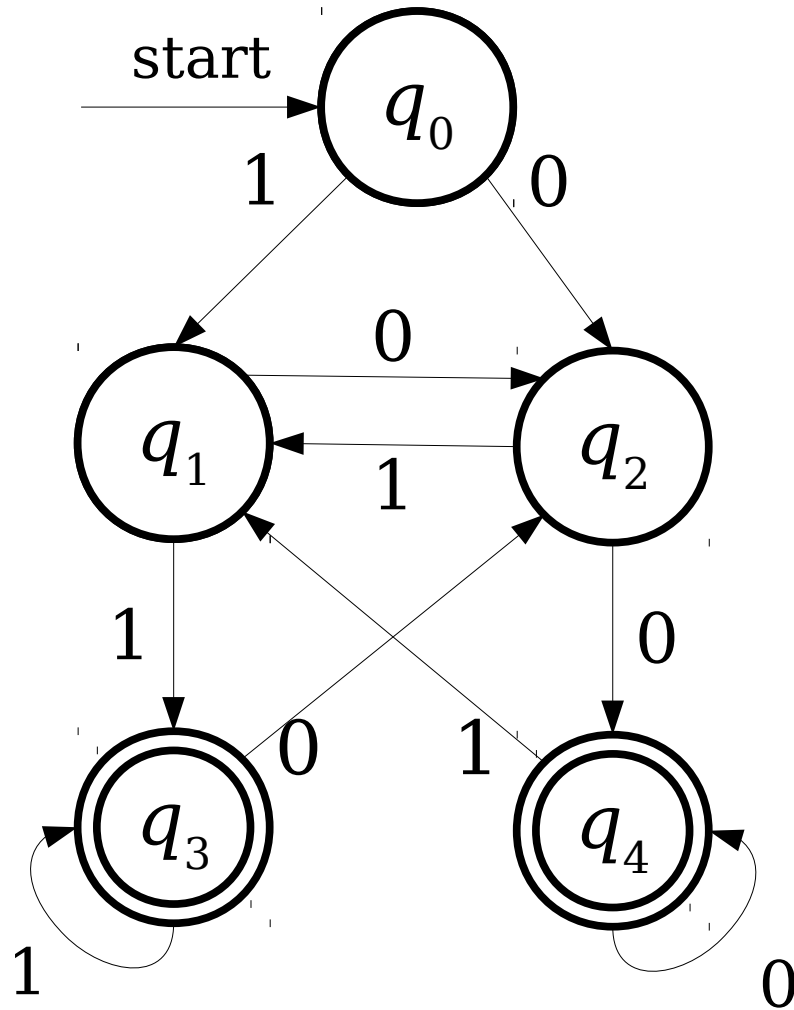

1 1 0 1

Just Passing Through

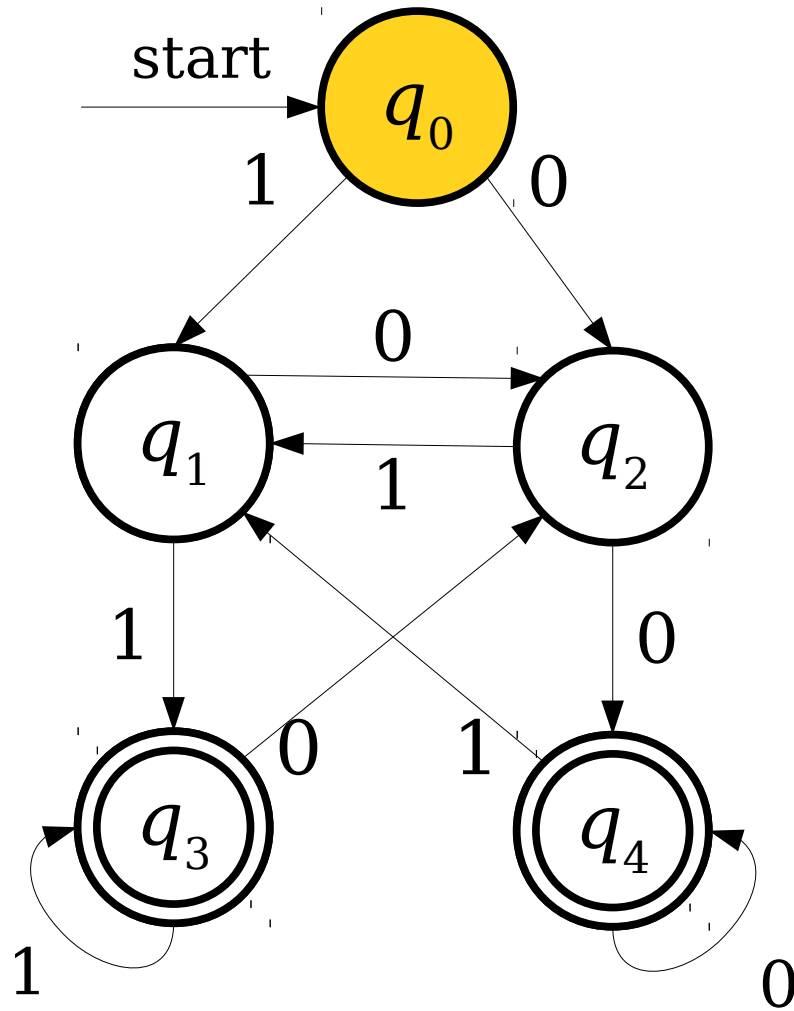

1 1 0 1

Just Passing Through

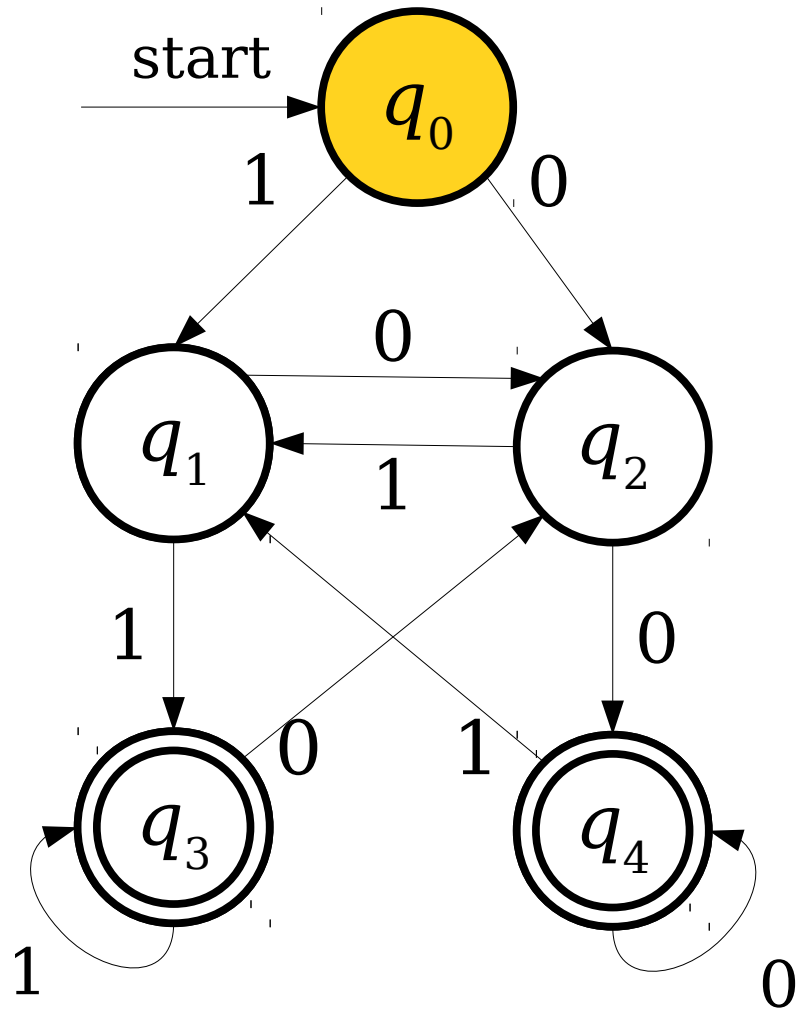

Just Passing Through

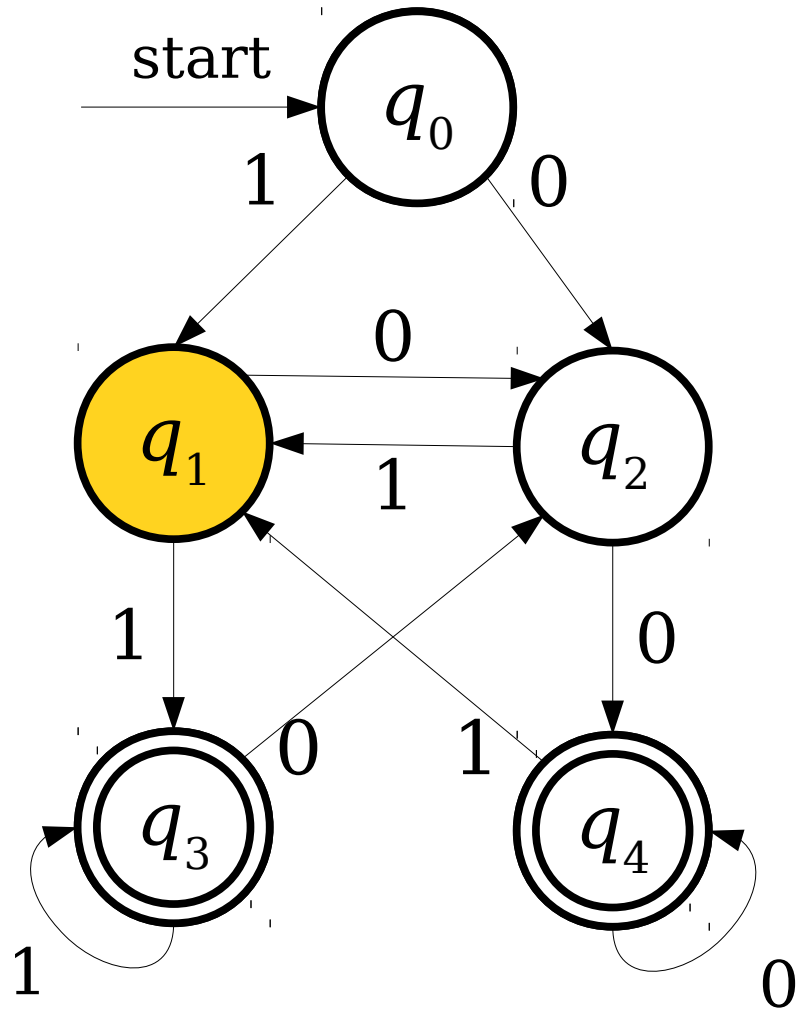

Just Passing Through

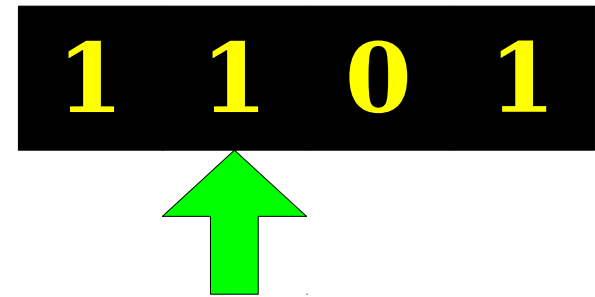
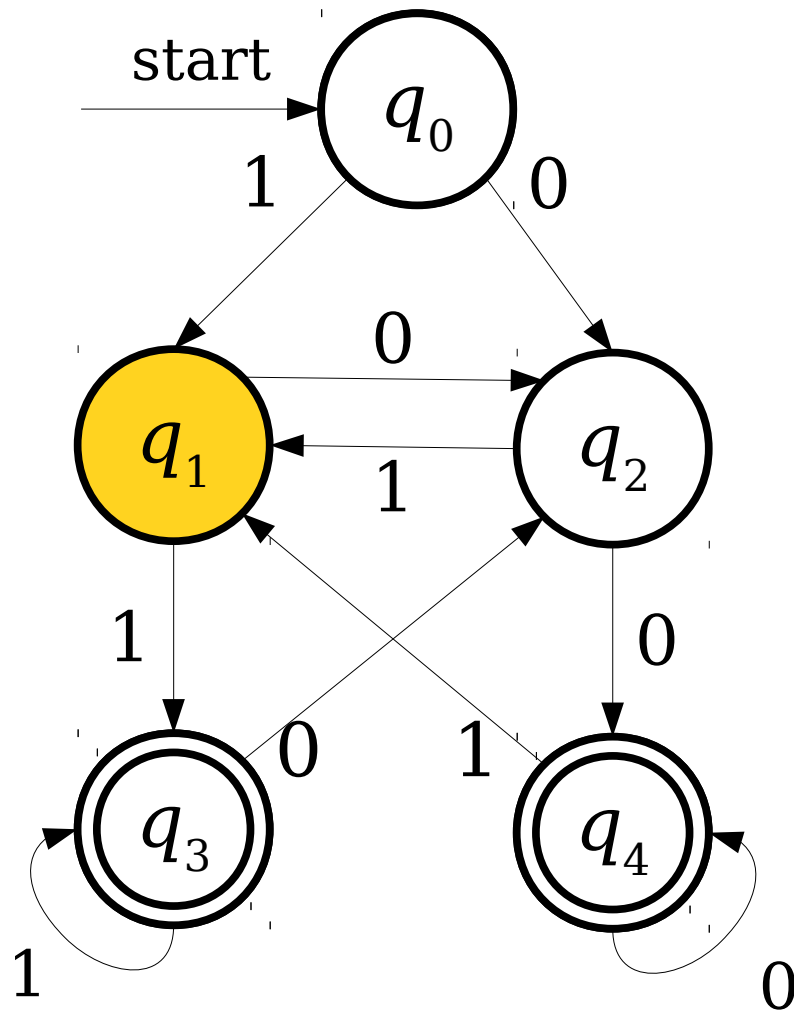

Just Passing Through

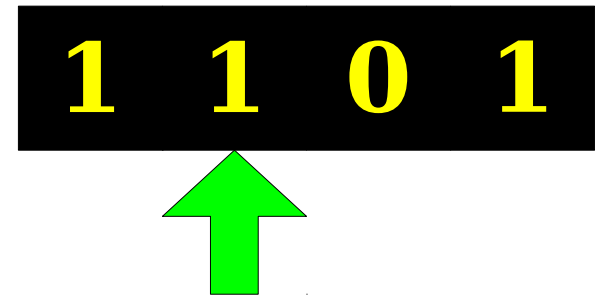
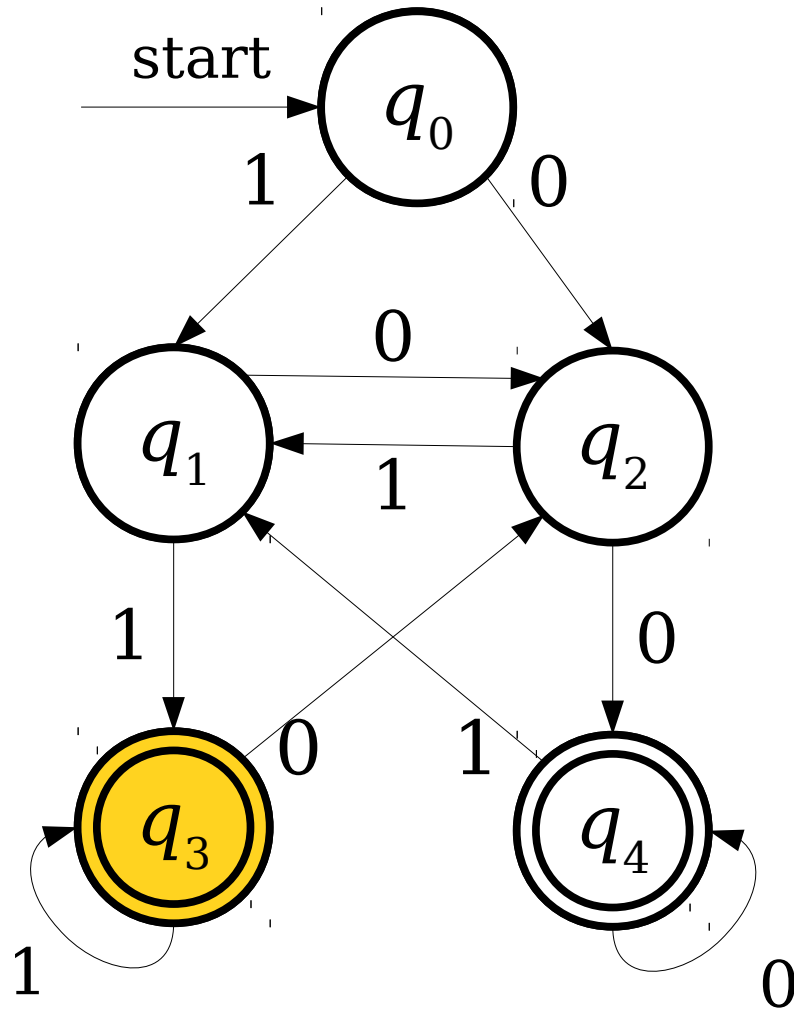

Just Passing Through

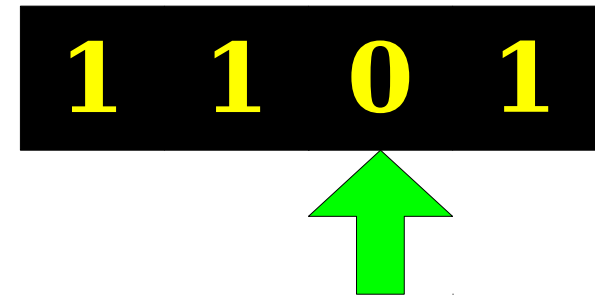
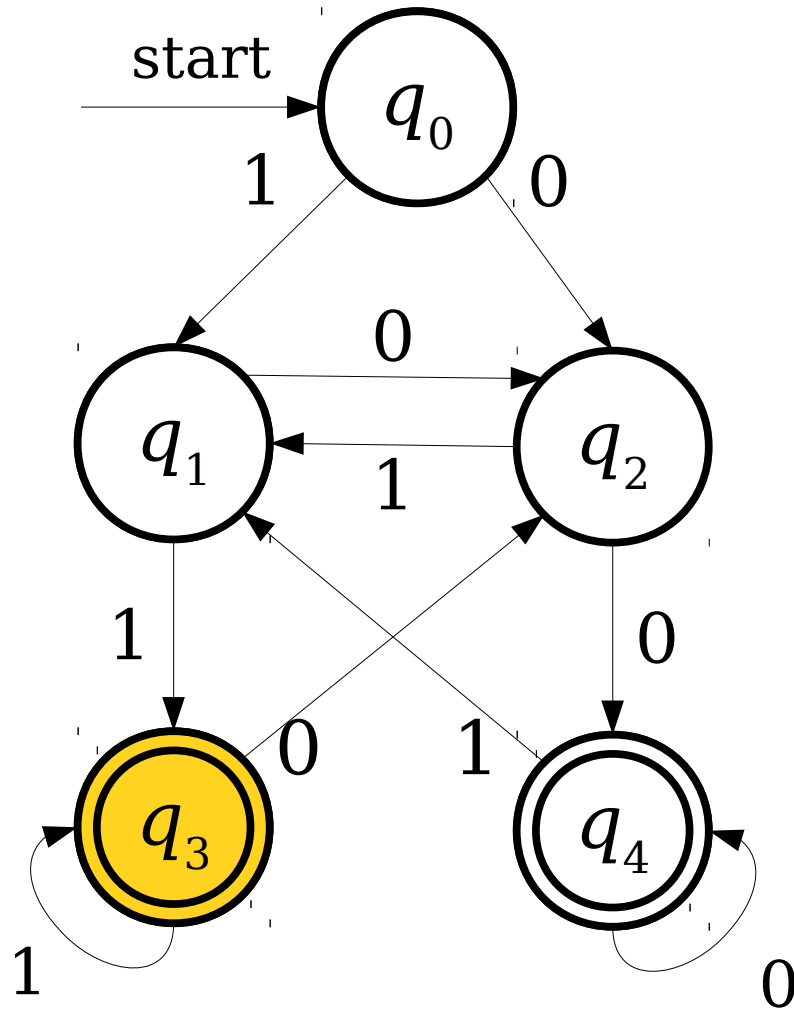

Just Passing Through

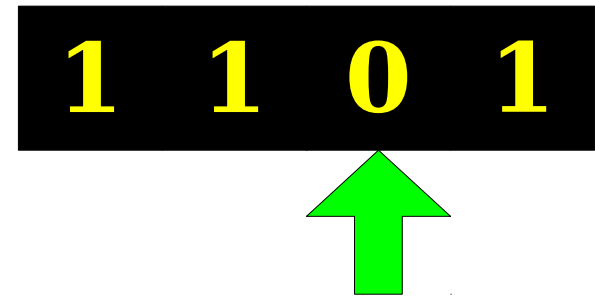
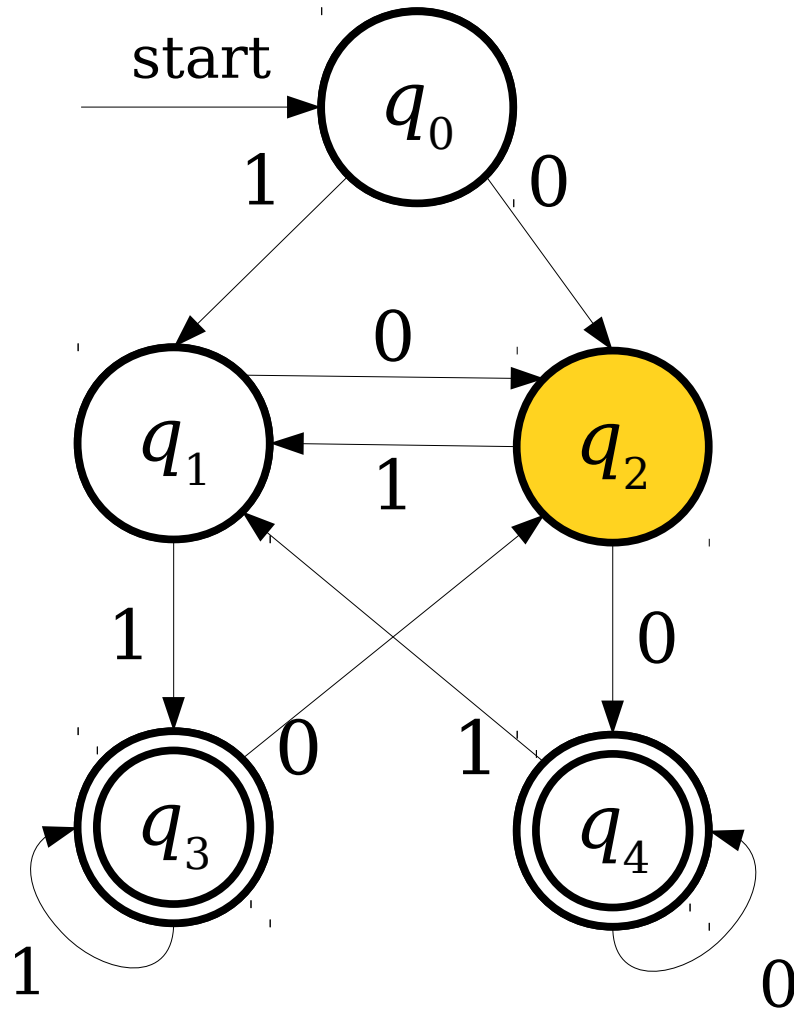

Just Passing Through

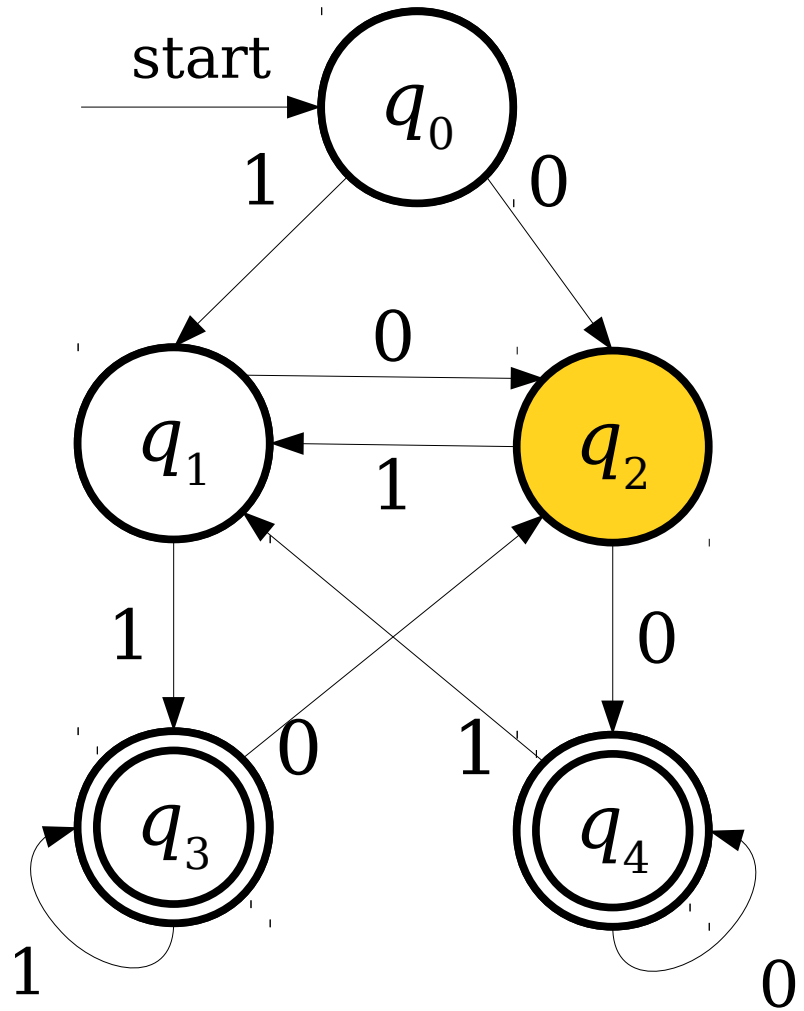

Just Passing Through

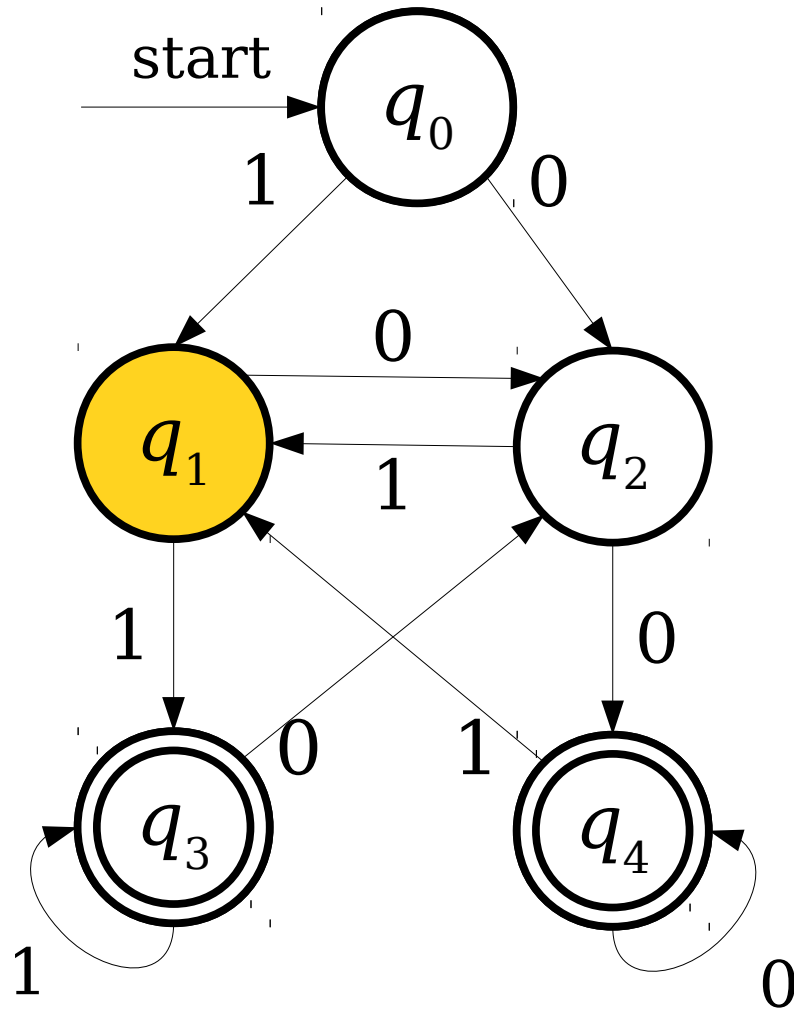

Just Passing Through

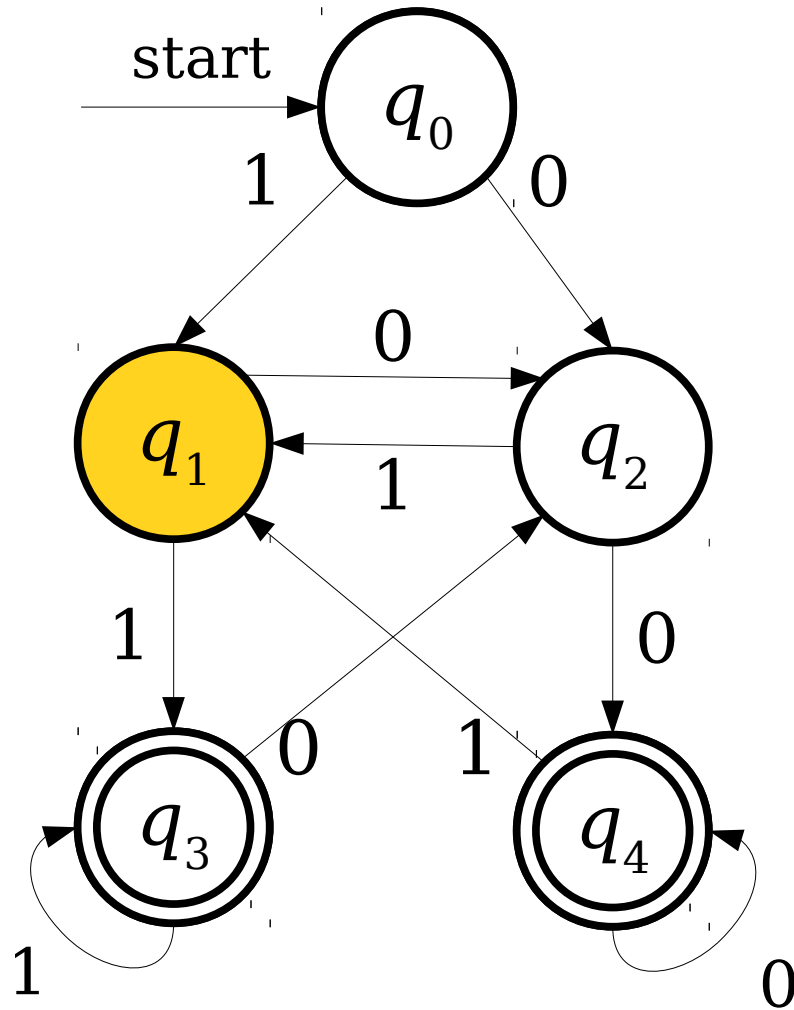

1 1 0 1

Just Passing Through

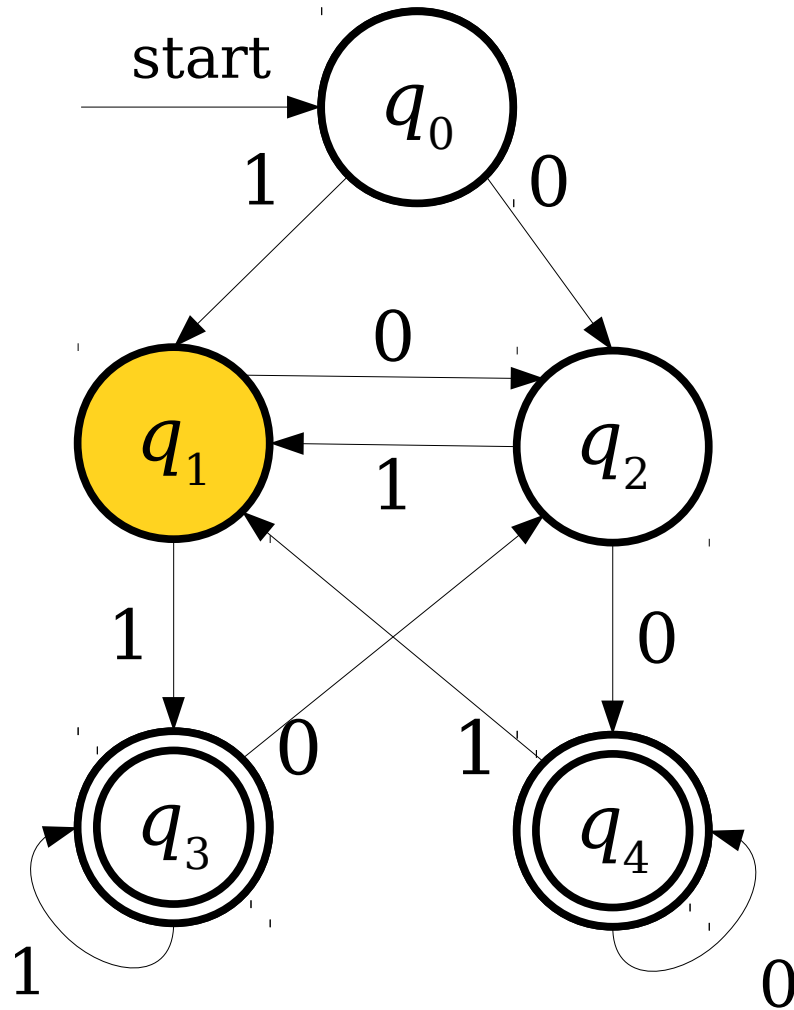

1 1 0 1

Just Passing Through

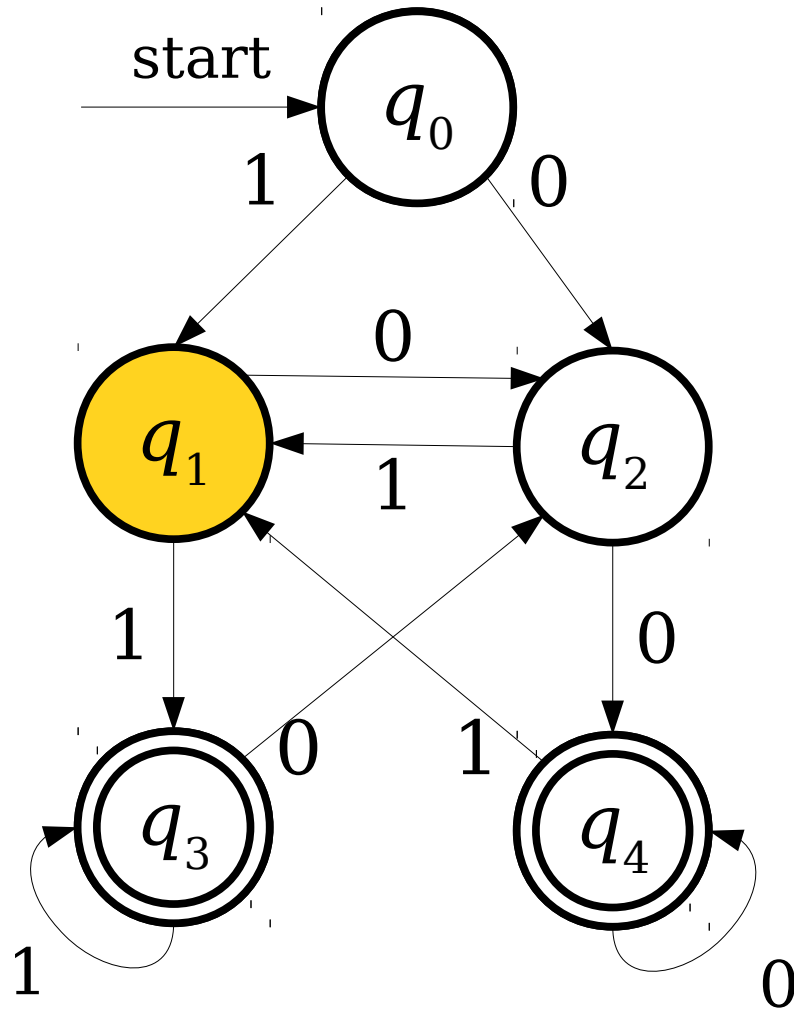

1 1 0 1



A finite automaton does *not* accept as soon as it enters an accepting state.

A finite automaton accepts if it *ends* in an accepting state.

What Does This Accept?

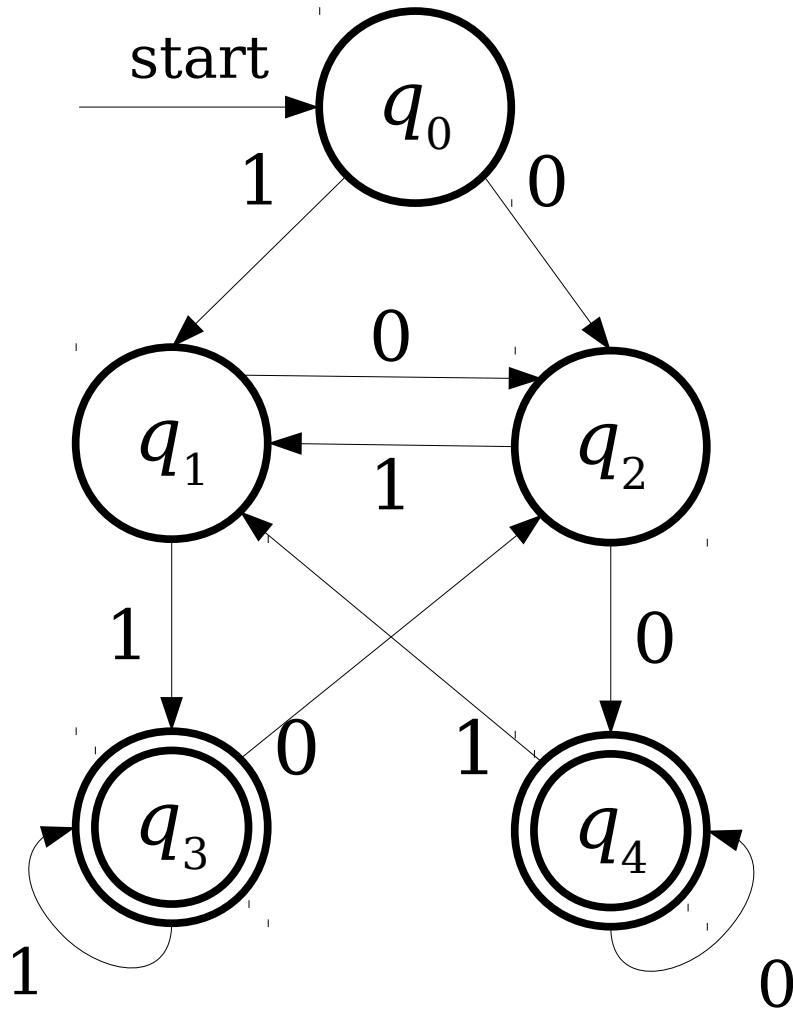

What Does This Accept?

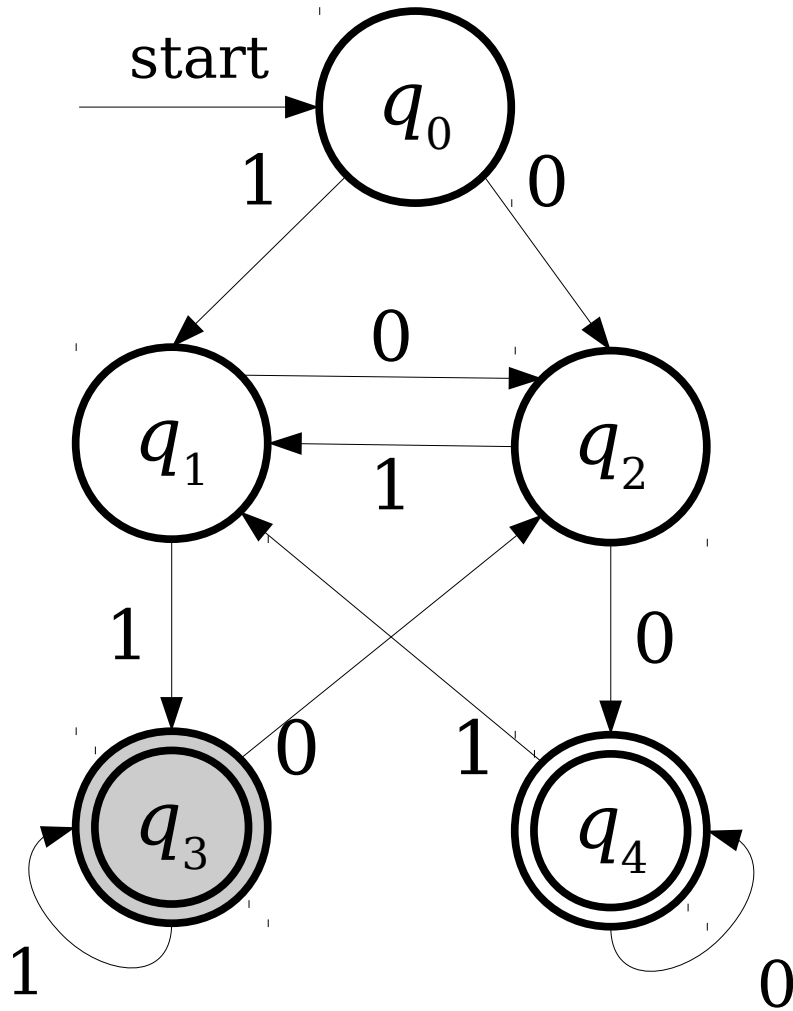

What Does This Accept?

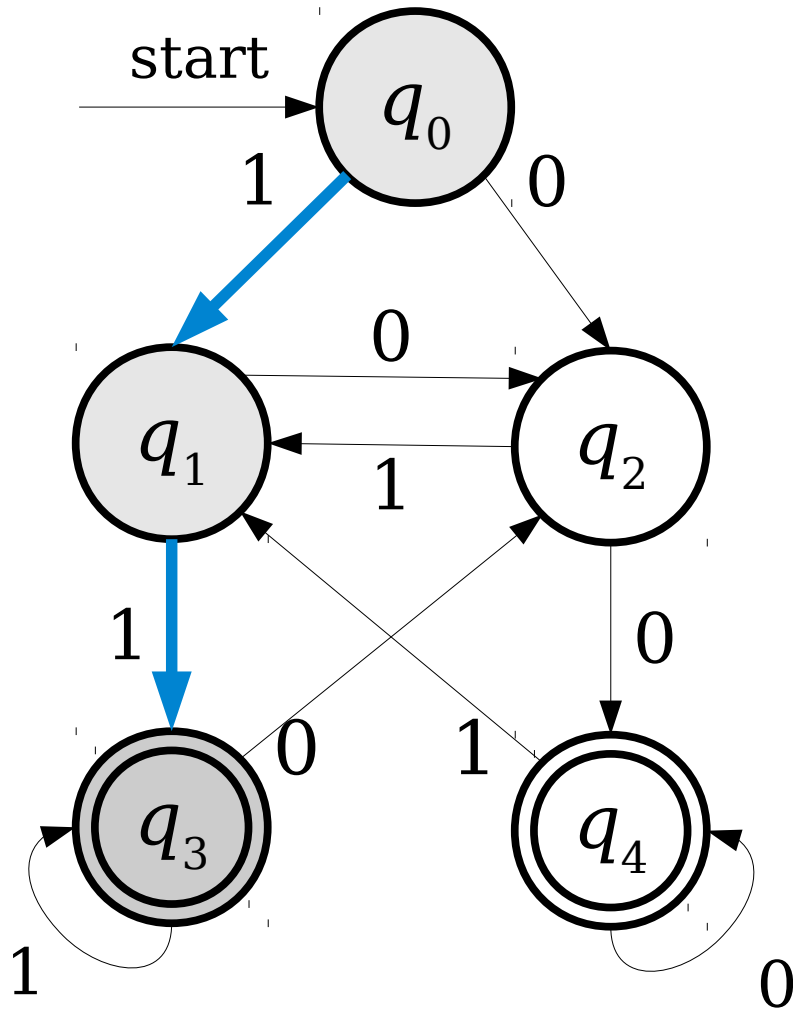

What Does This Accept?

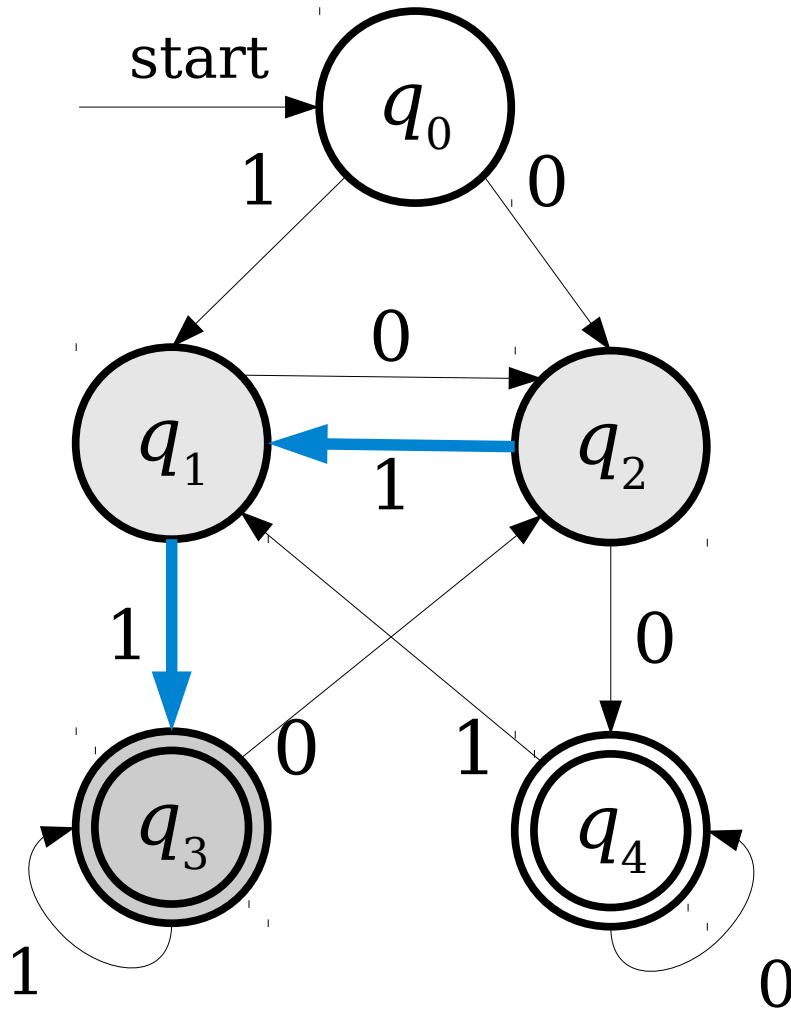

What Does This Accept?

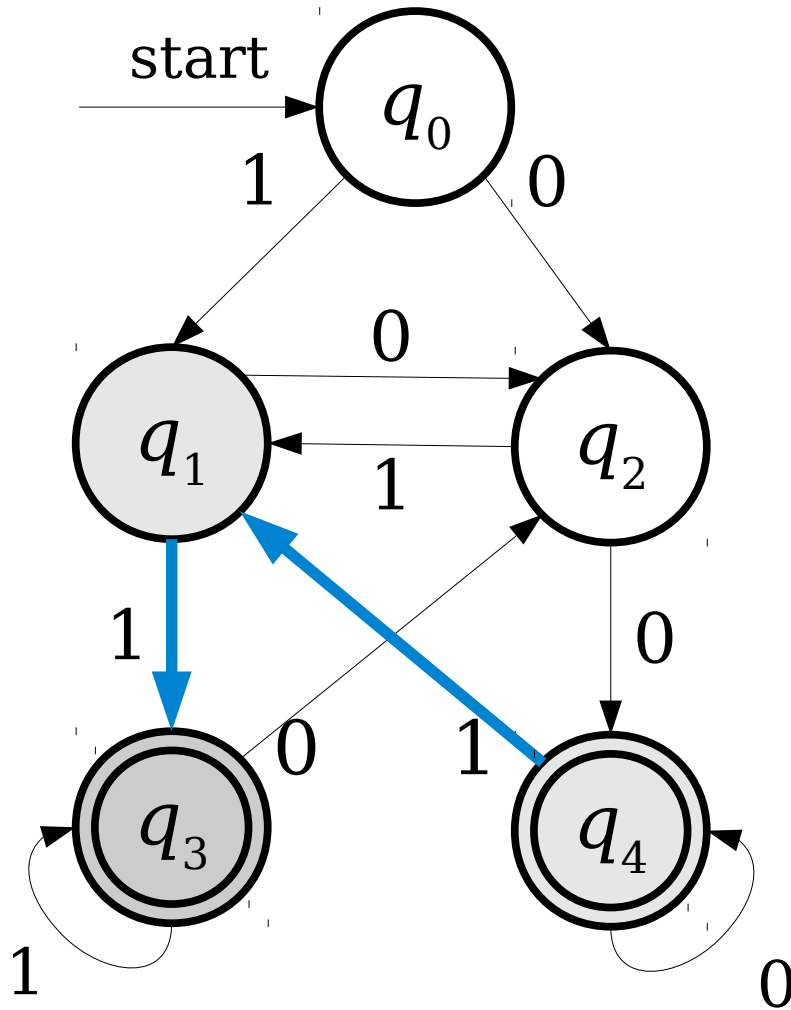

What Does This Accept?

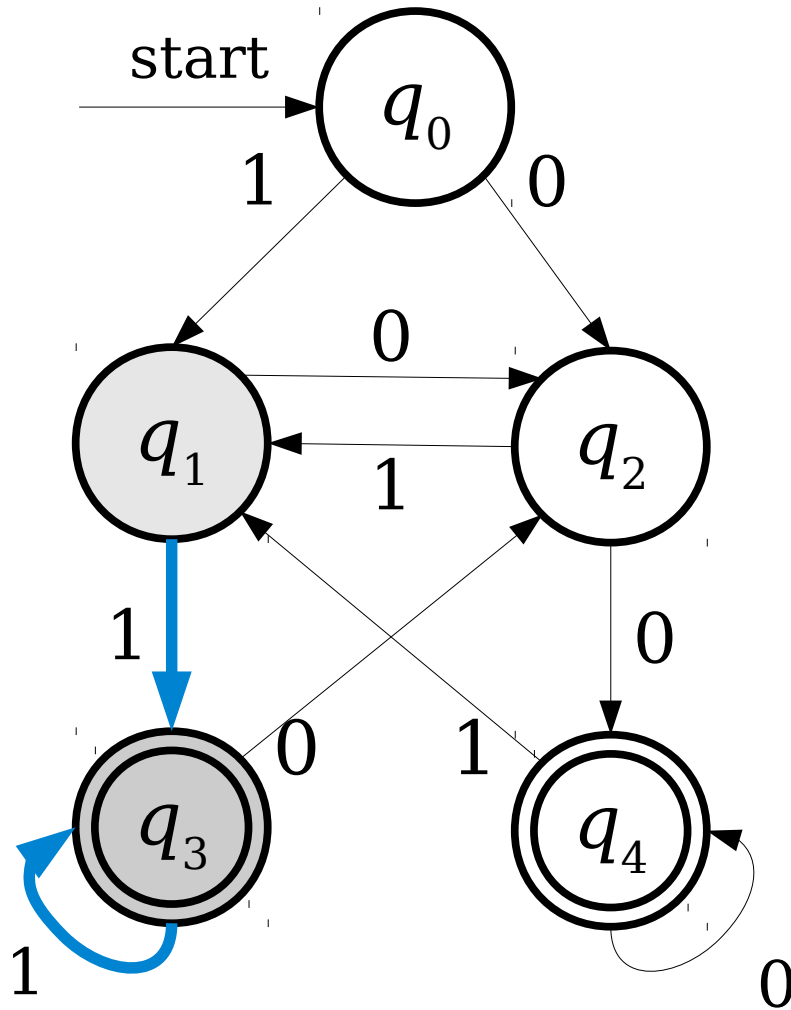

What Does This Accept?

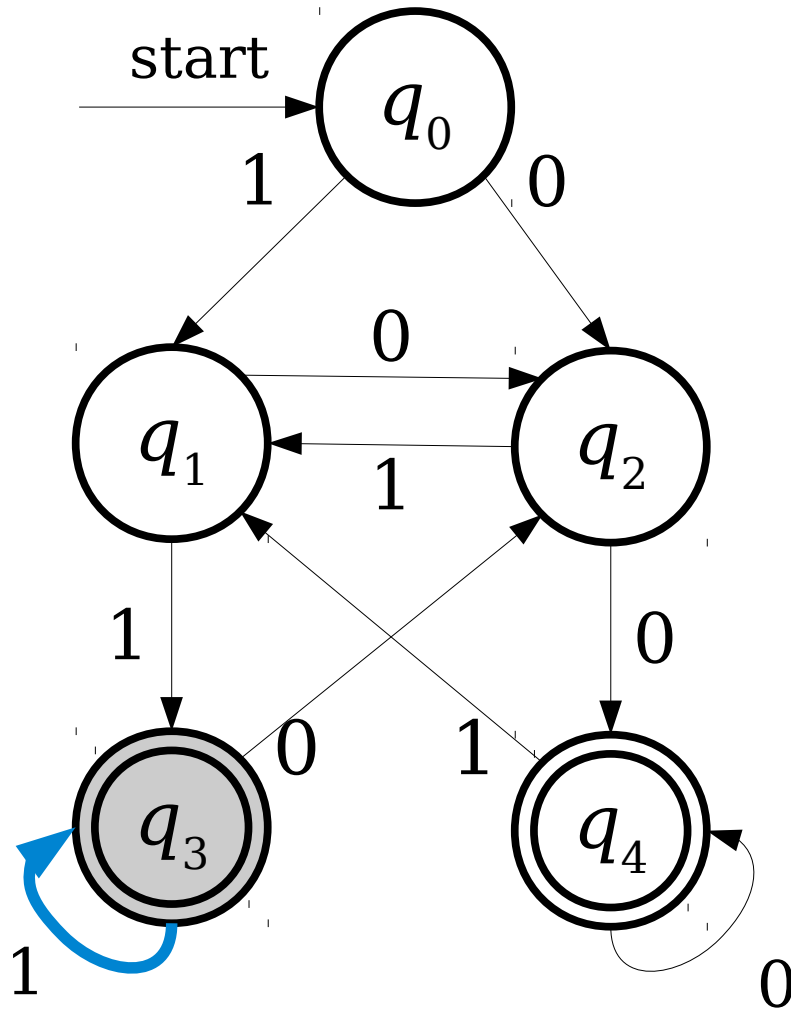

What Does This Accept?

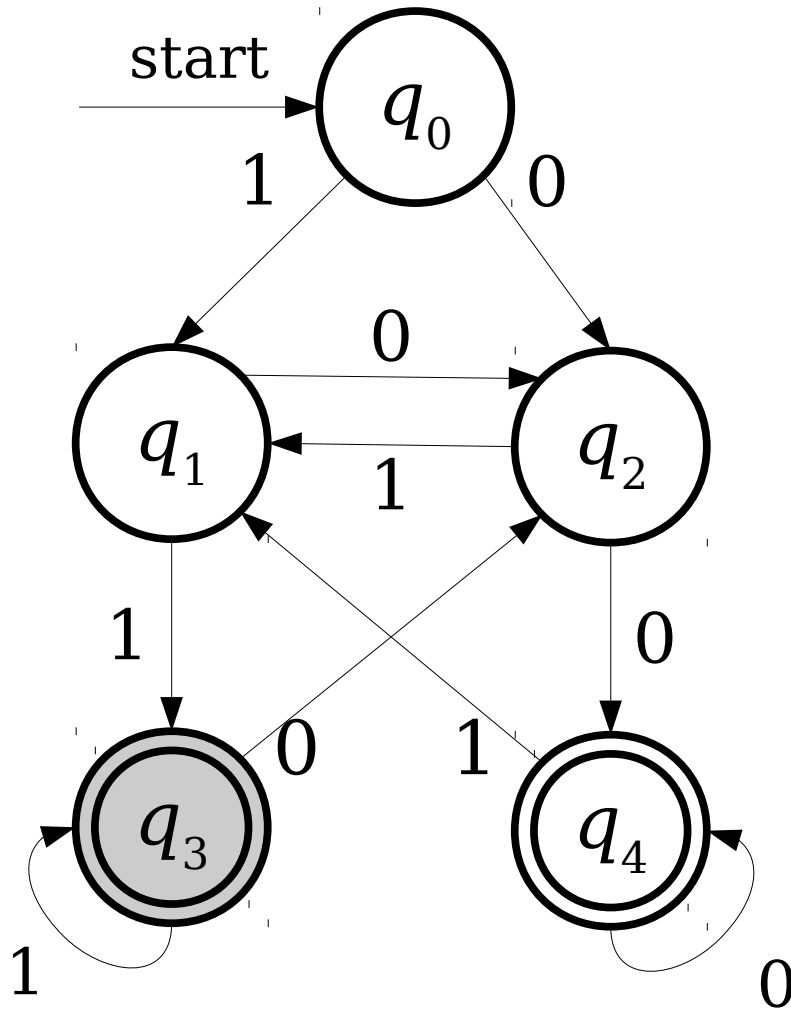

No matter where we start in the automaton, after seeing two 1's, we end up in accepting state q_3 .

What Does This Accept?

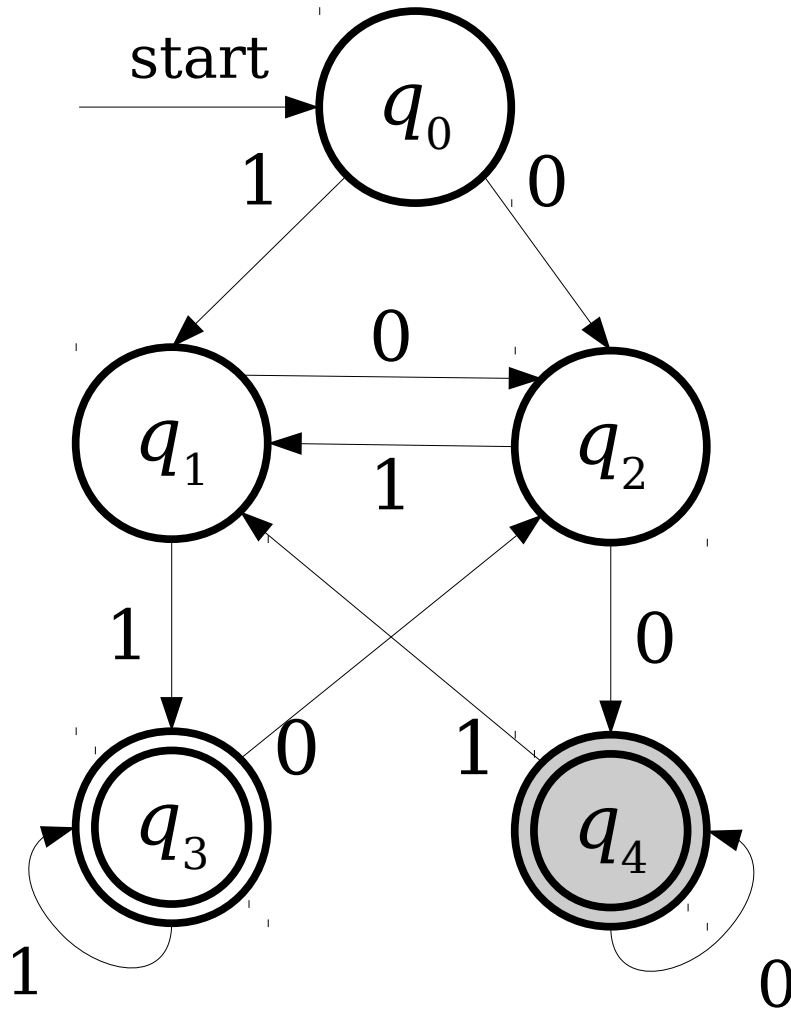

What Does This Accept?

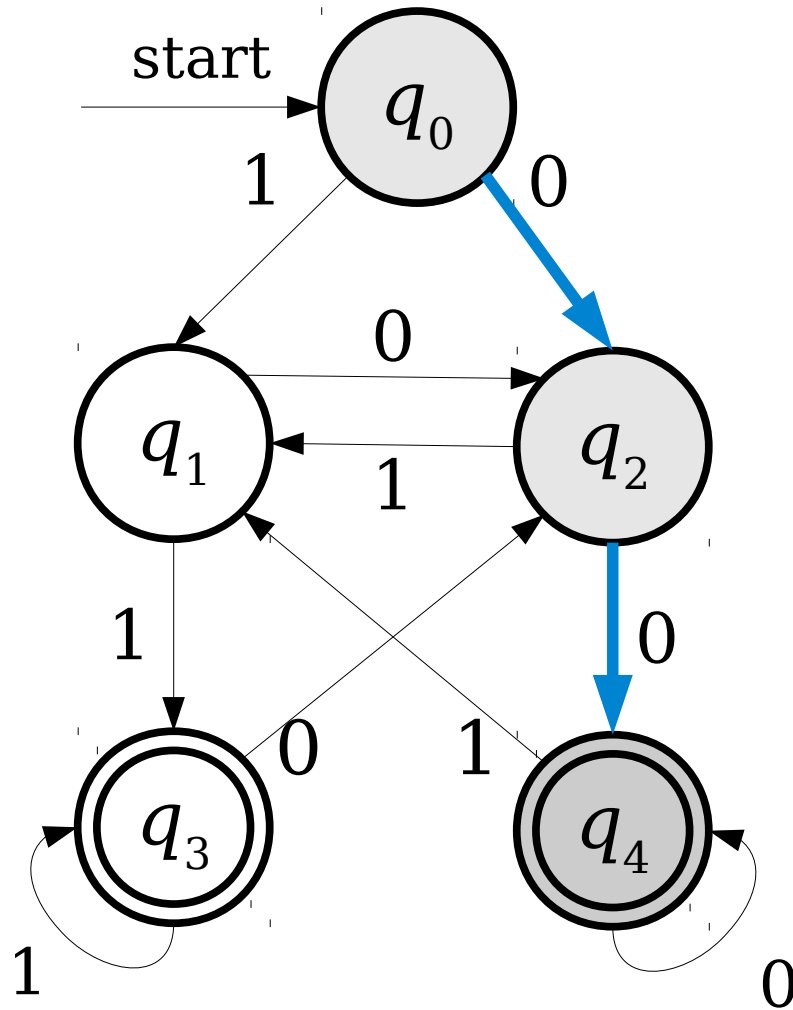

What Does This Accept?

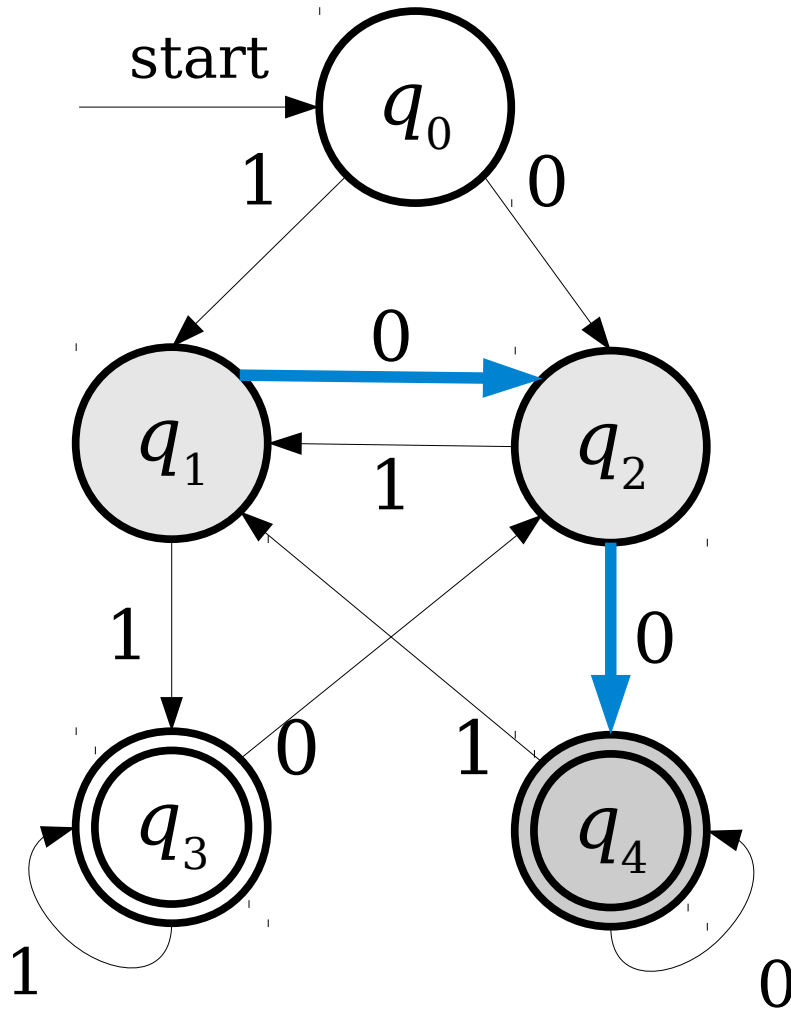

What Does This Accept?

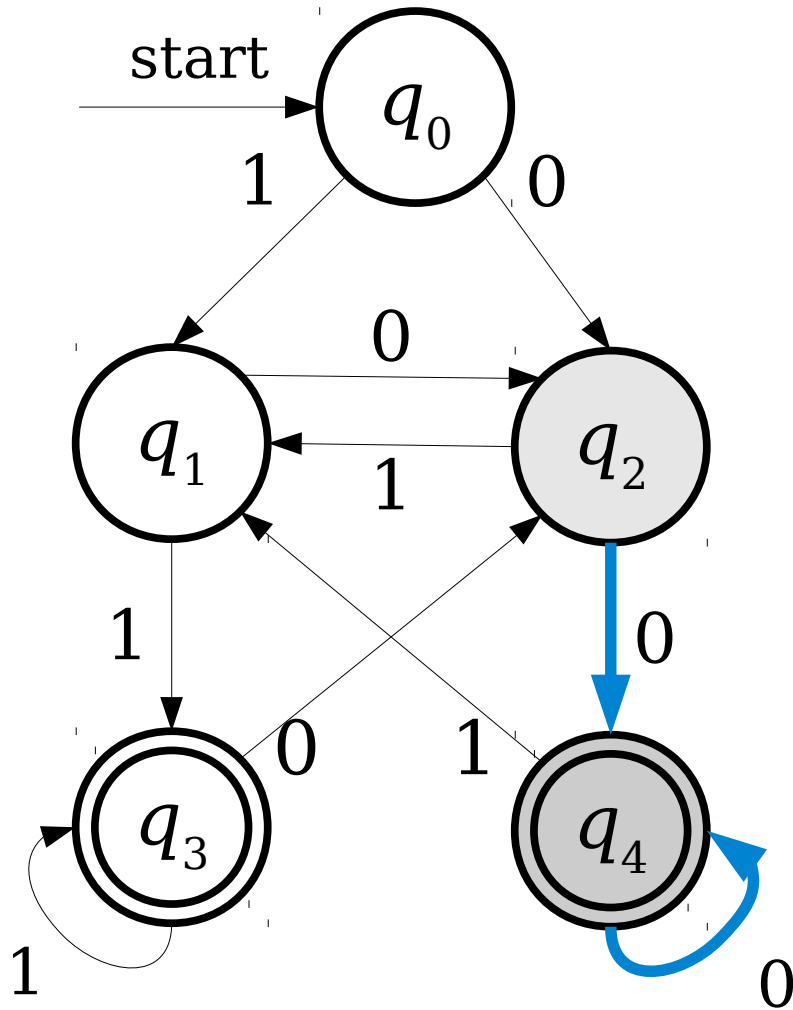

What Does This Accept?

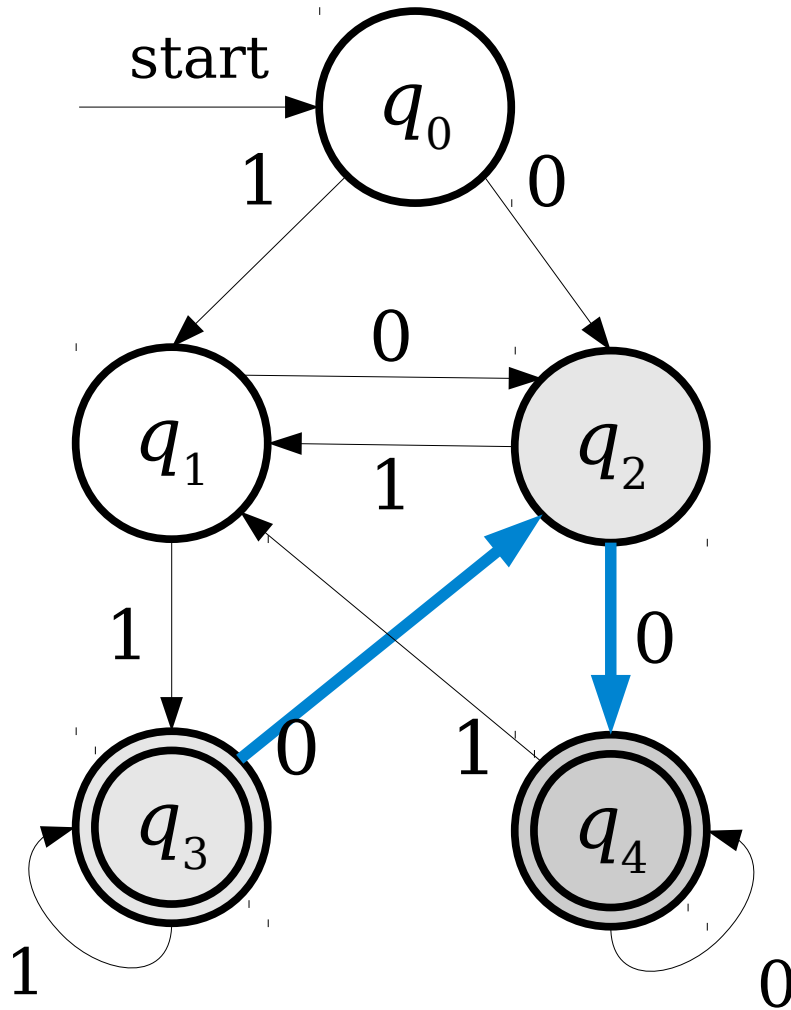

What Does This Accept?

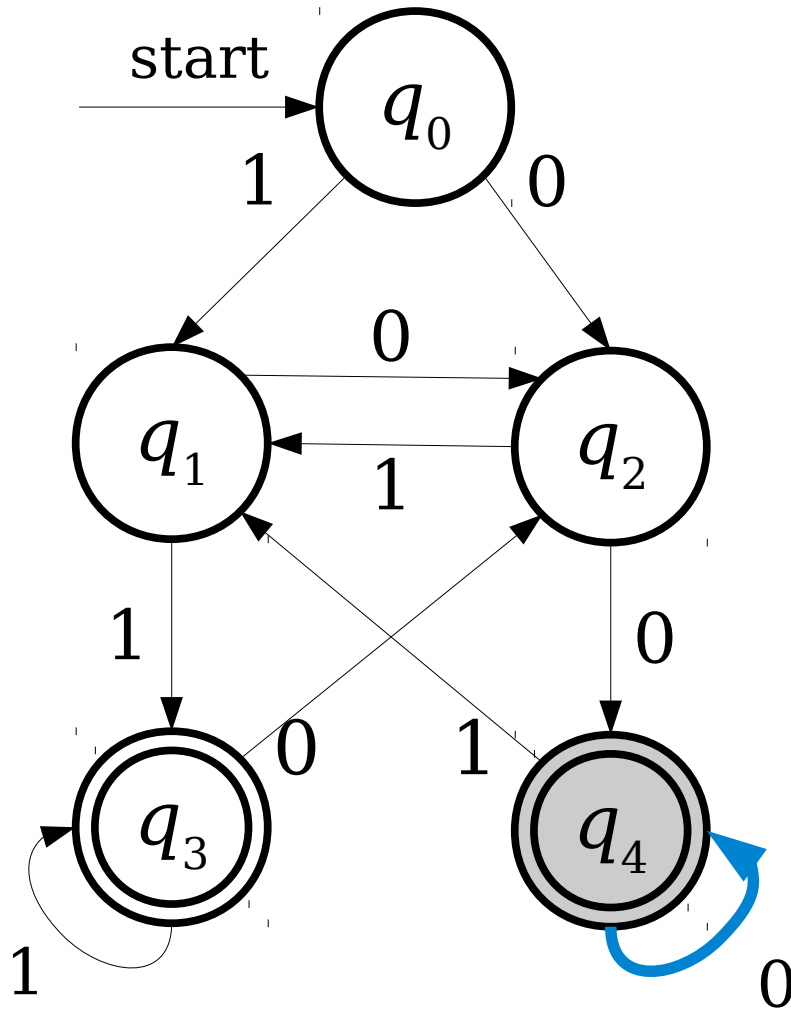

What Does This Accept?

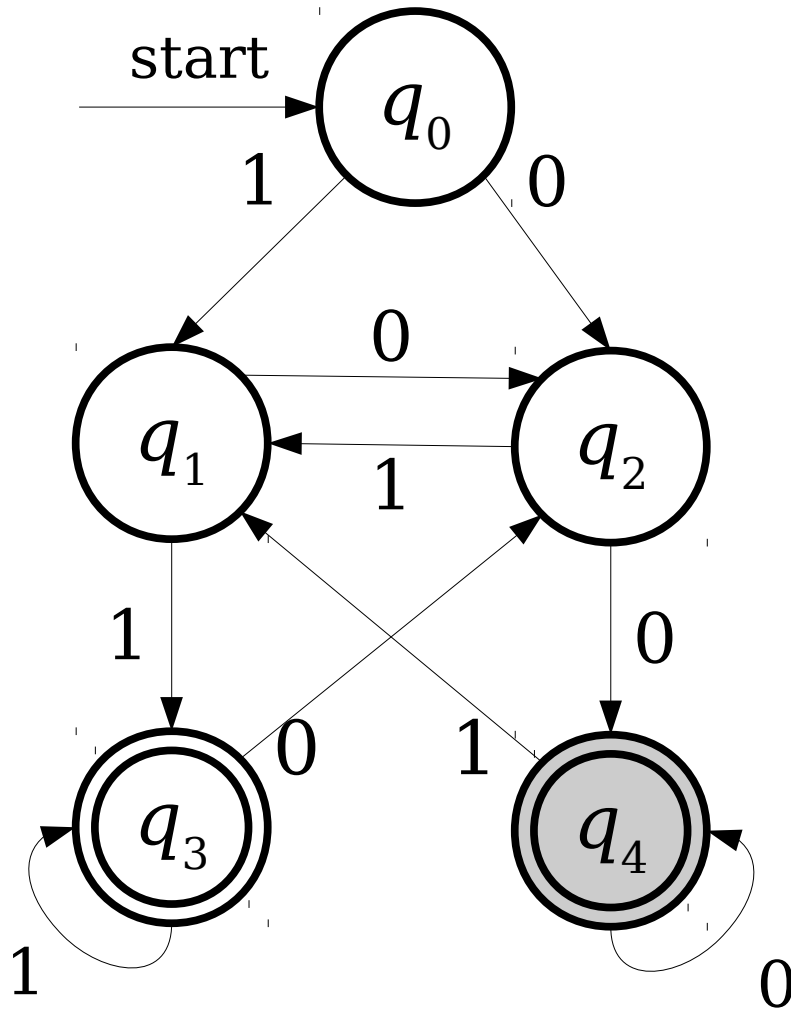

No matter where we start in the automaton, after seeing two 0's, we end up in accepting state q_5 .

What Does This Accept?

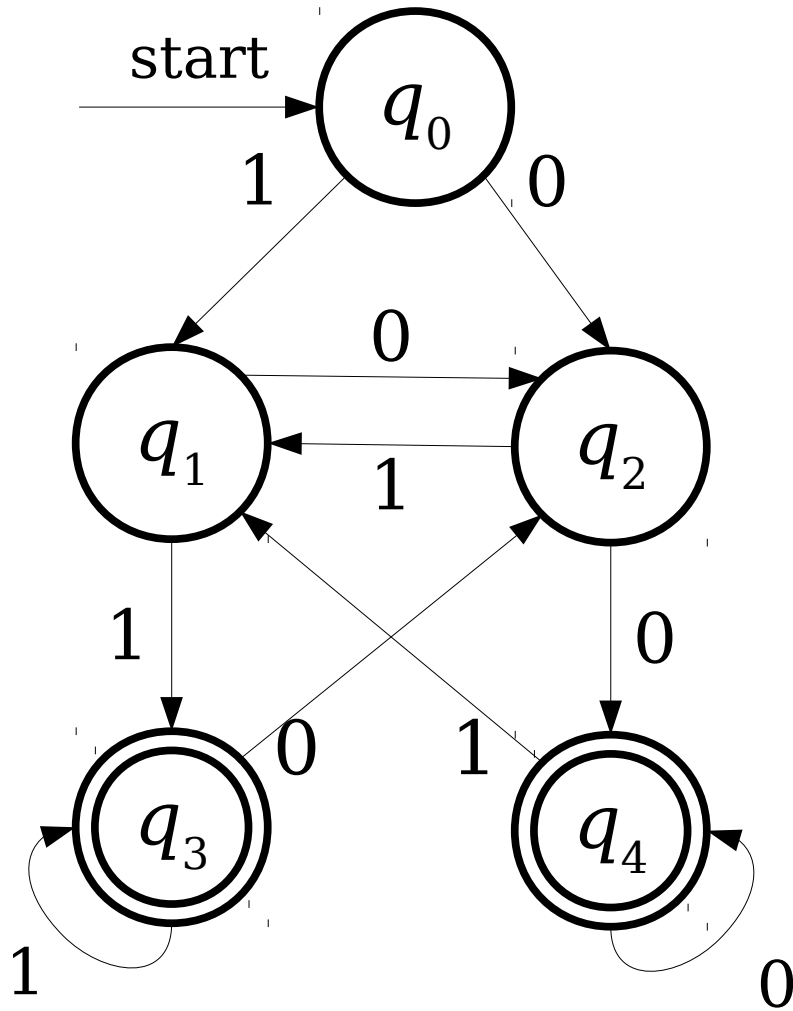

What Does This Accept?

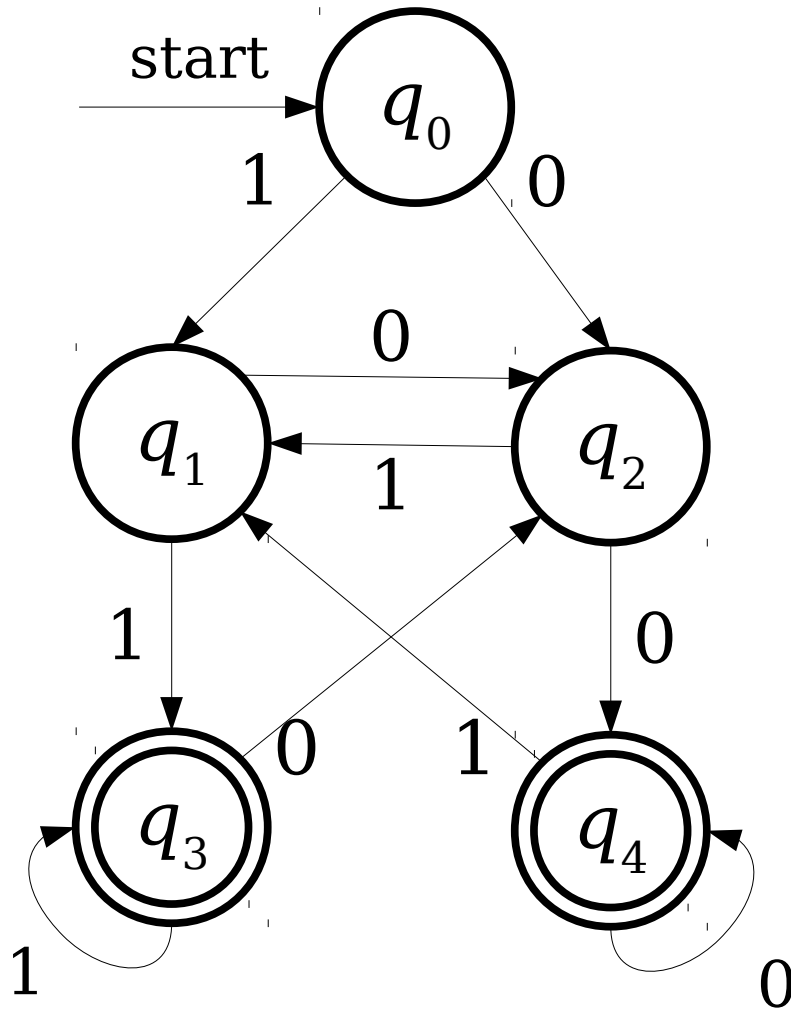

This automaton accepts a string in $\{0, 1\}^*$ iff the string ends in **00** or **11**.

The *language of an automaton* is the set of strings that it accepts.

If D is an automaton that processes characters from the alphabet Σ , then $\mathcal{L}(D)$ is formally defined as

$$\mathcal{L}(D) = \{ w \in \Sigma^* \mid D \text{ accepts } w \}$$

How many of the following statements are true?

- ***A language*** of an automaton can have an infinitely long string (or many of them) in it.
- ***A language*** of an automaton can contain infinitely many strings.
- ***A language*** of an automaton can contain no strings.

Answer at **PolleEv.com/cs103** or
text **CS103** to **22333** once to join, then a **number**.

A Small Problem

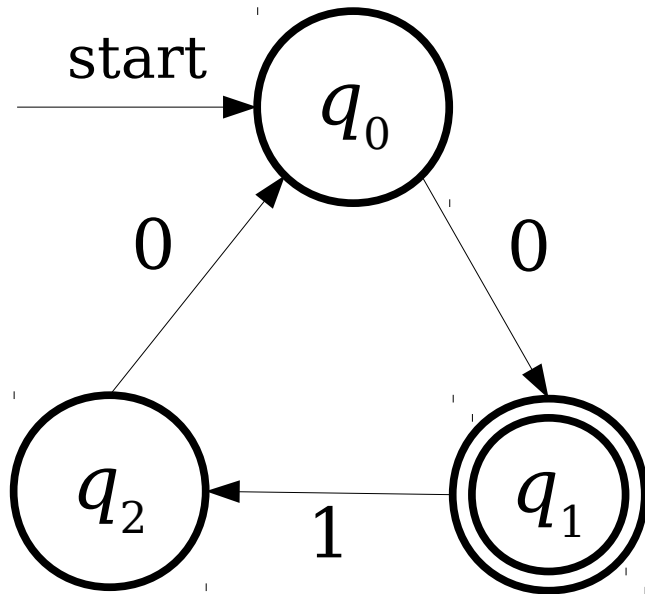

A Small Problem

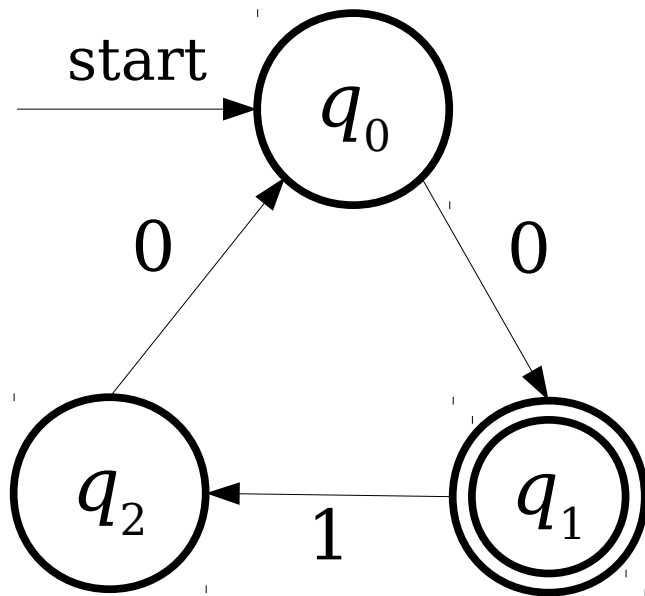

0 1 1 0

A Small Problem

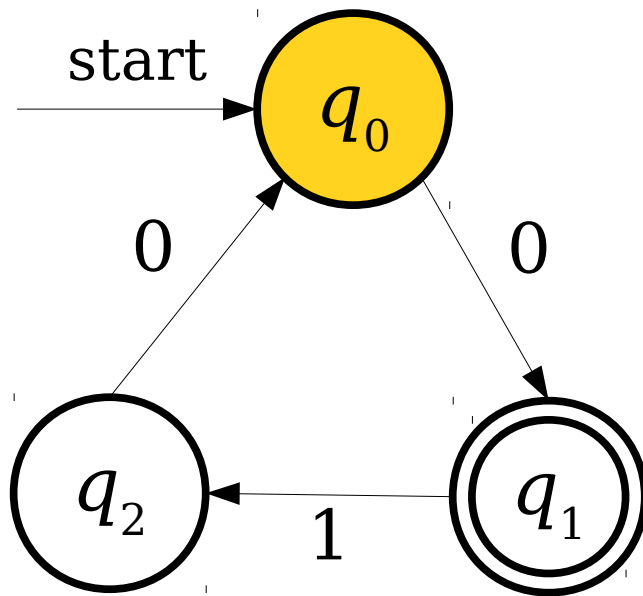

0 1 1 0

A Small Problem

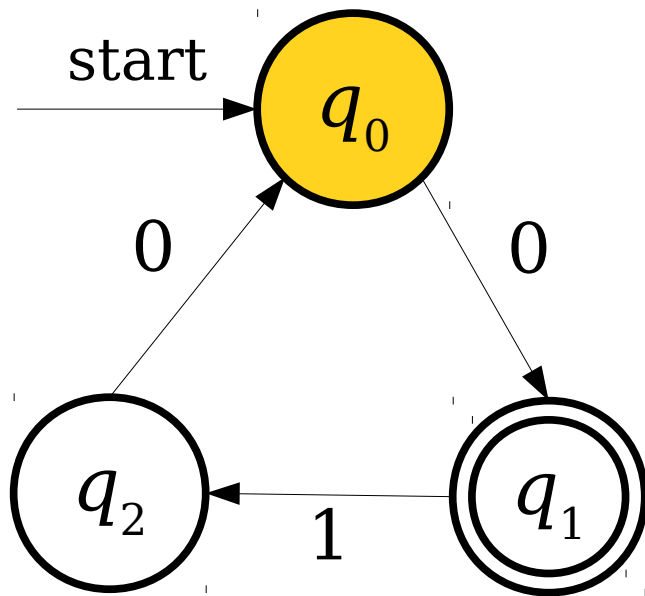

A Small Problem

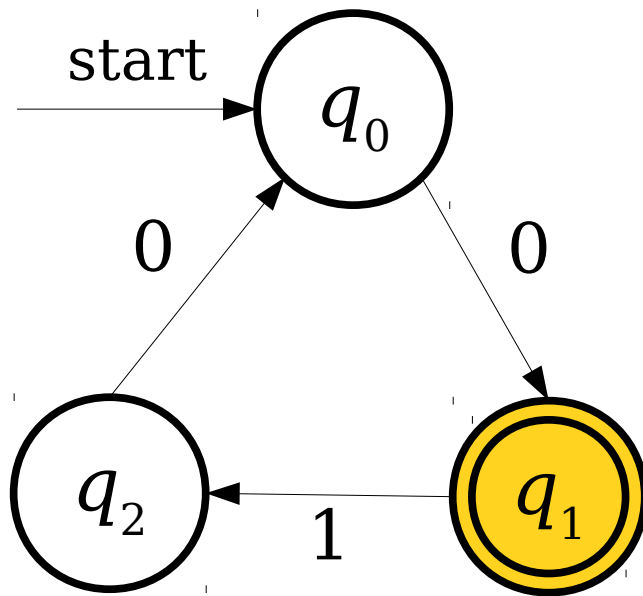

A Small Problem

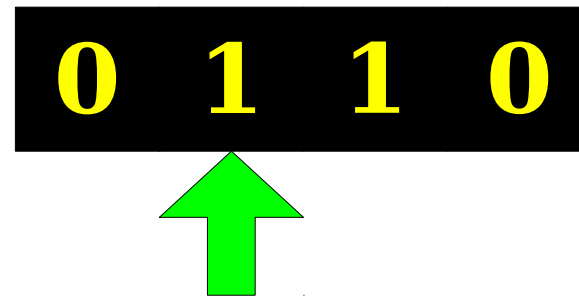
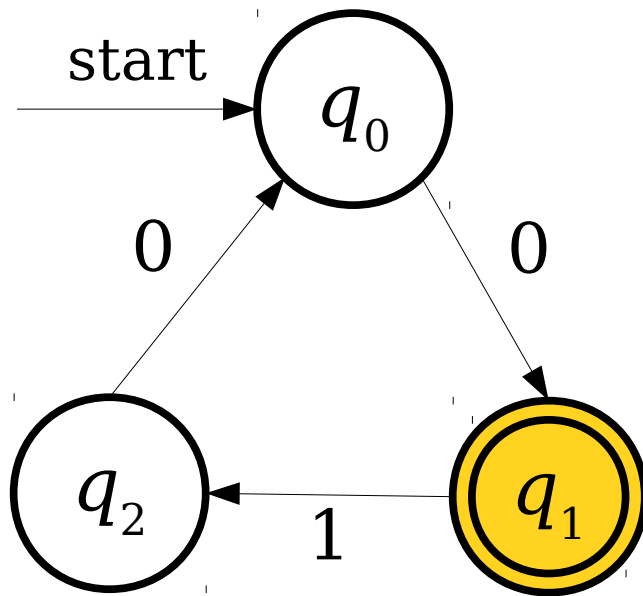

A Small Problem

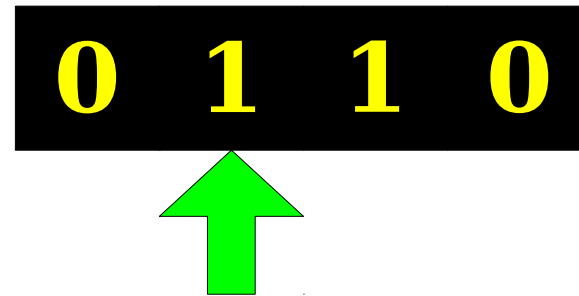
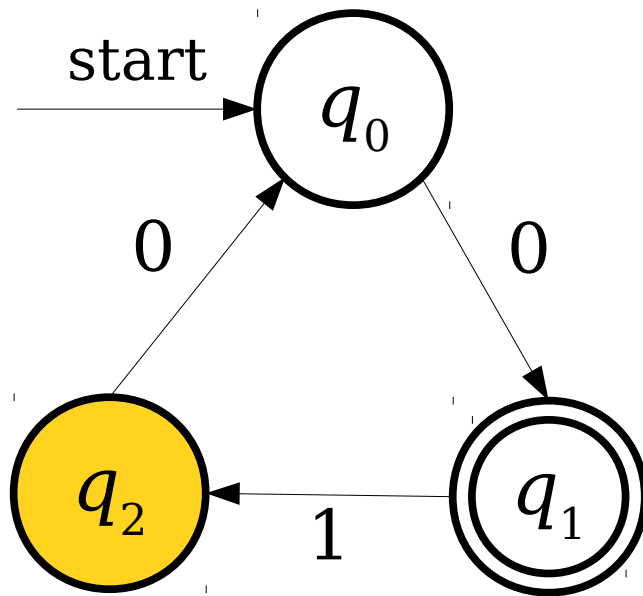

A Small Problem

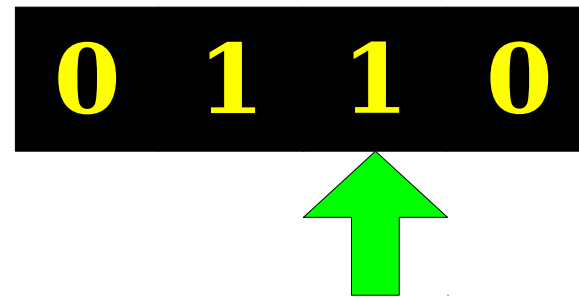
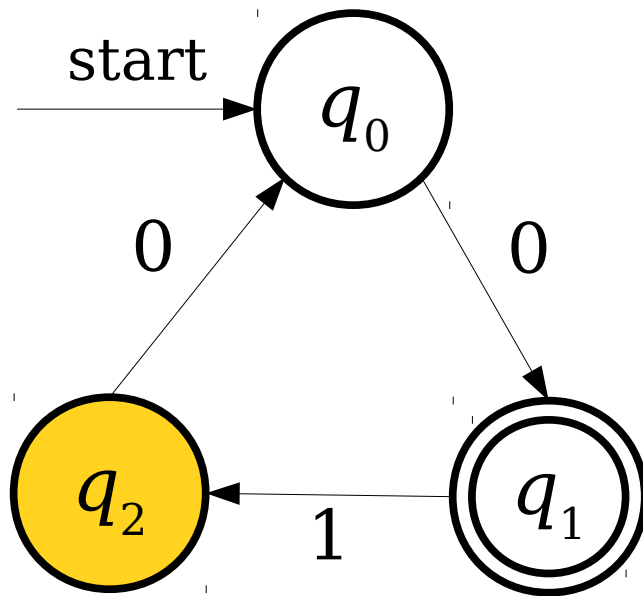

A Small Problem

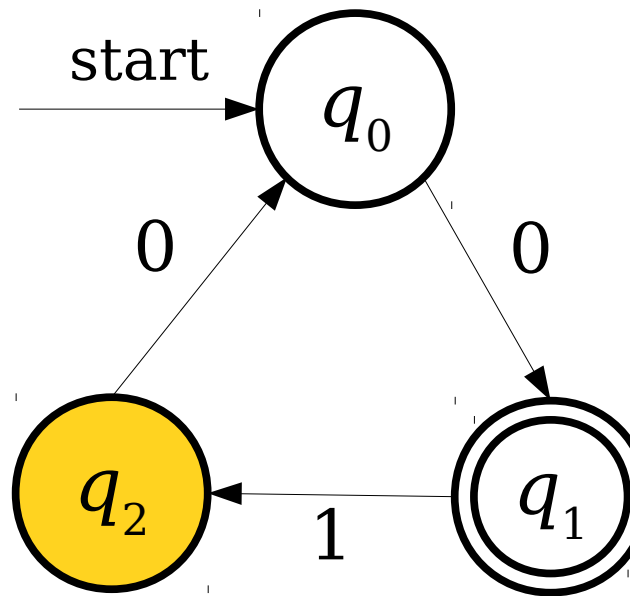

0 1 1 0

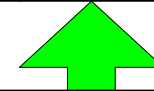

Another Small Problem

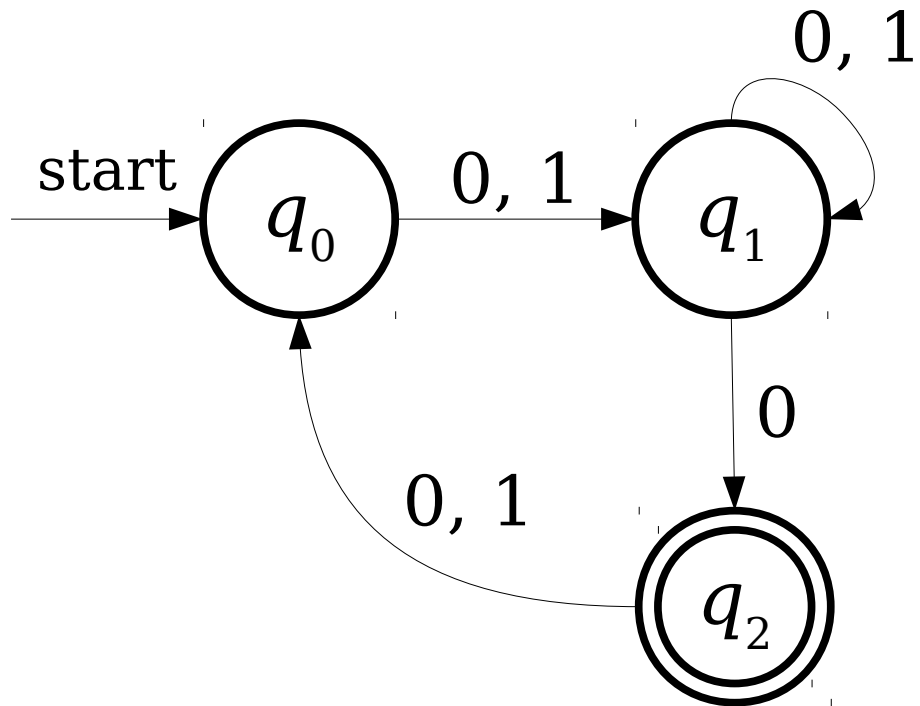

Another Small Problem

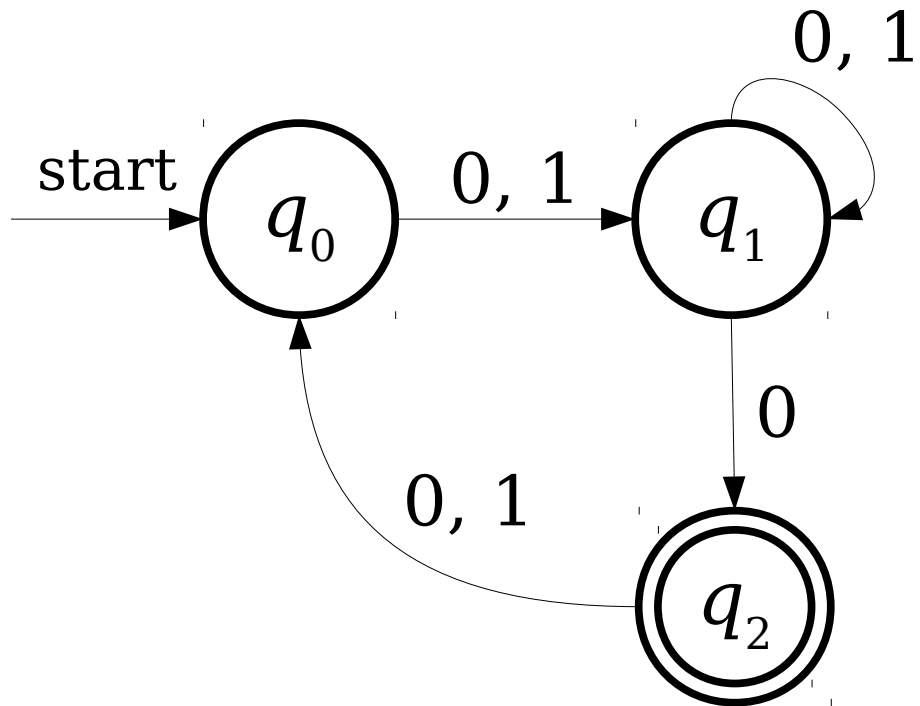

0 0 0

Another Small Problem

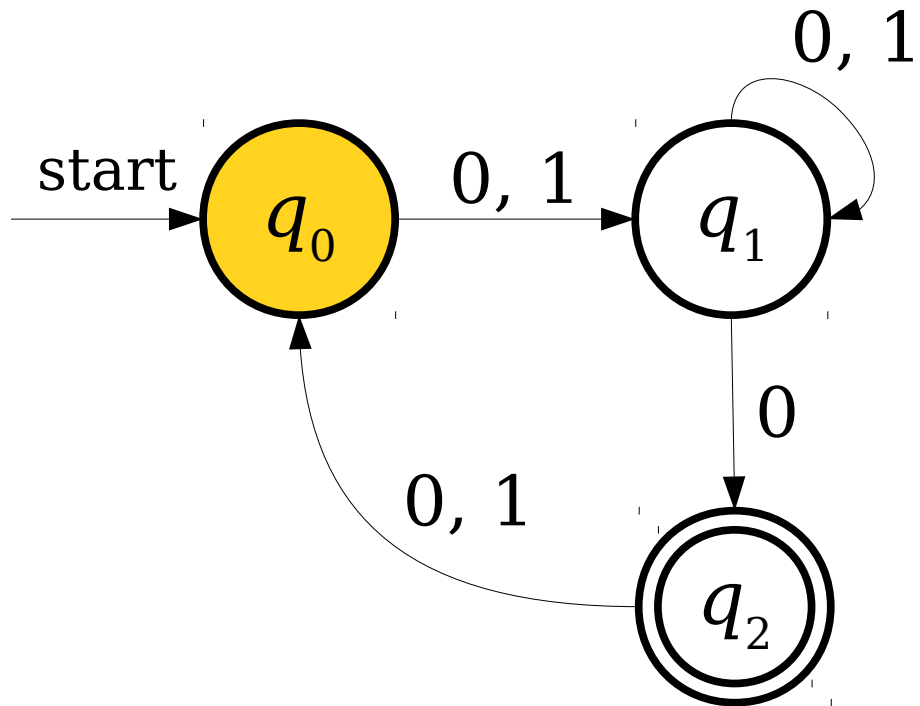

0 0 0

Another Small Problem

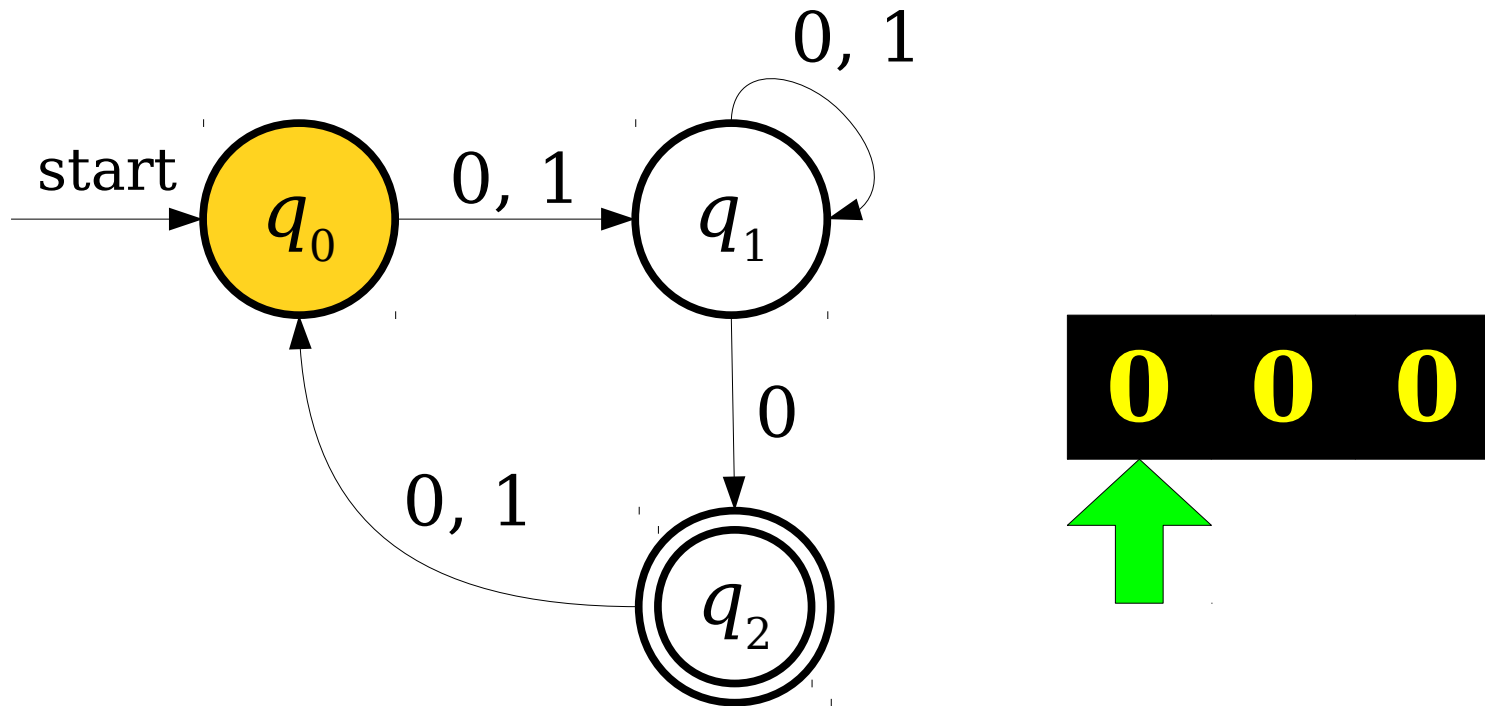

Another Small Problem

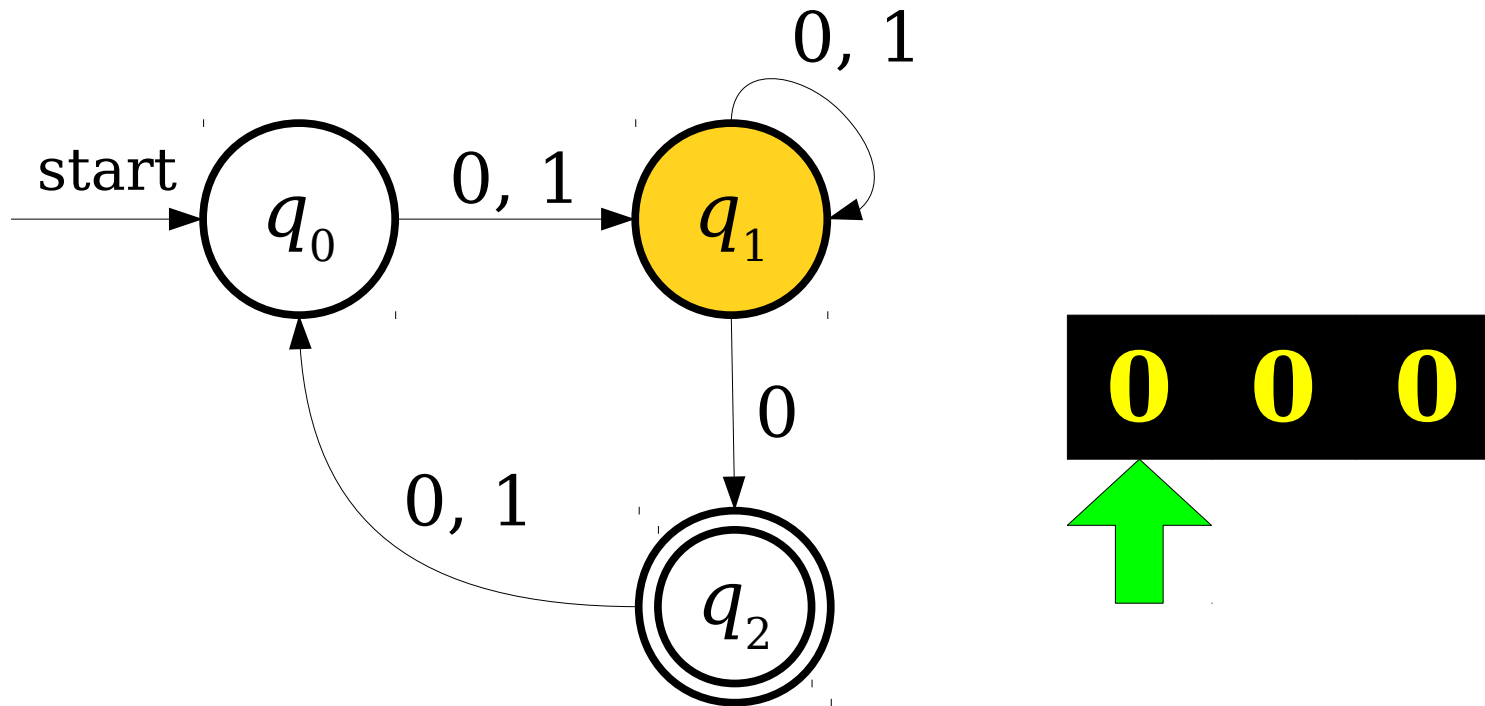

Another Small Problem

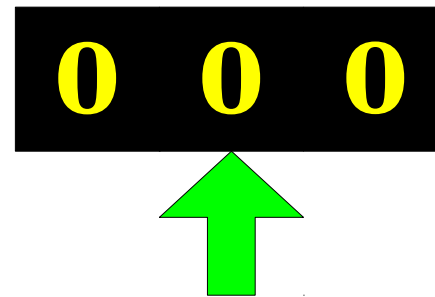
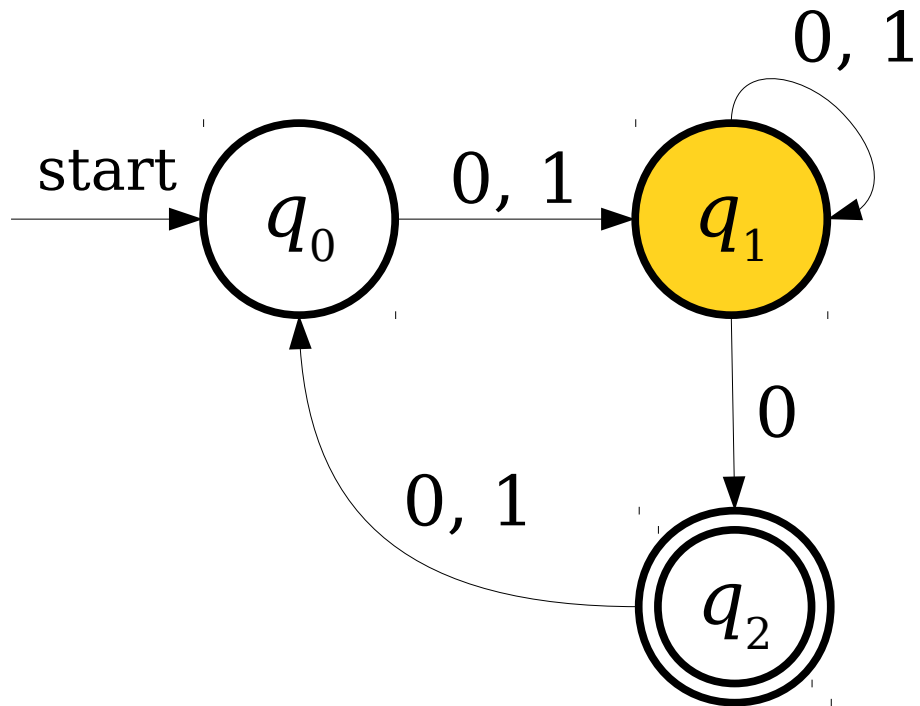

Another Small Problem

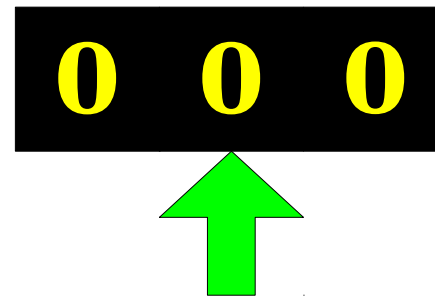
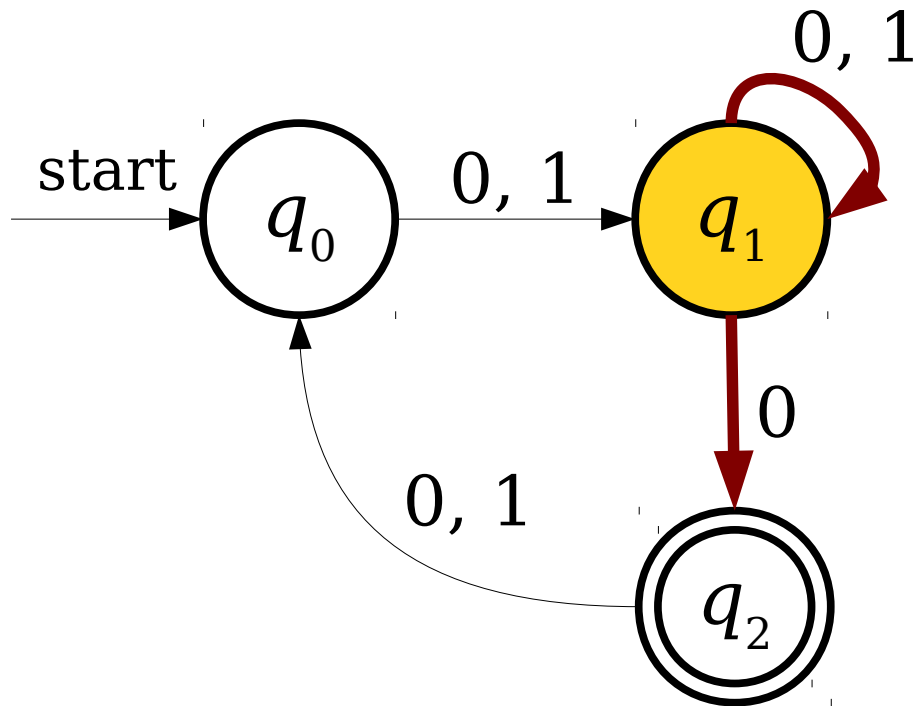

Another Small Problem

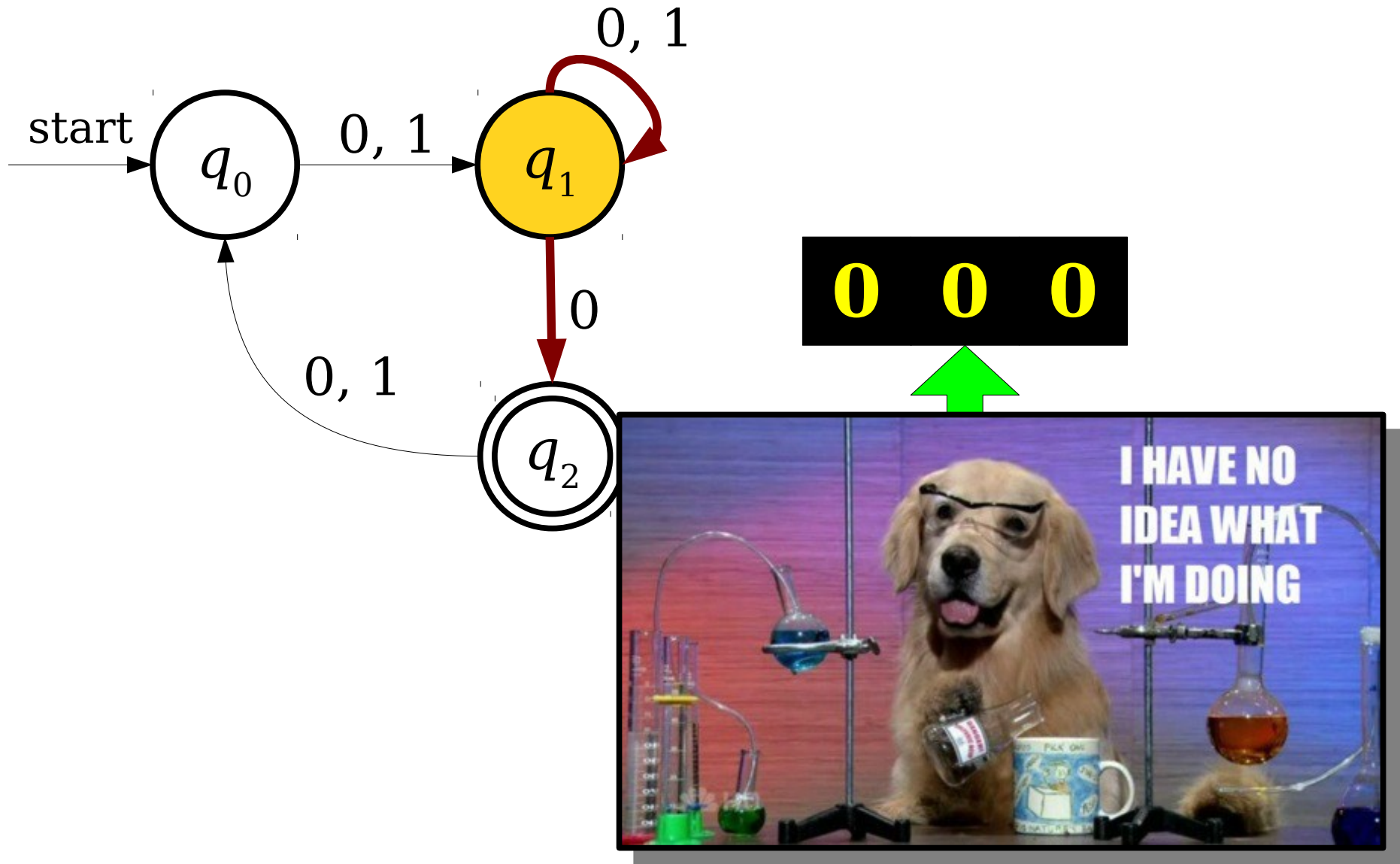

The Need for Formalism

- In order to reason about the limits of what finite automata can and cannot do, we need to formally specify their behavior in *all* cases.
- All of the following need to be defined or disallowed:
 - What happens if there is no transition out of a state on some input?
 - What happens if there are *multiple* transitions out of a state on some input?

DFAs

- A ***DFA*** is a
 - ***D***eterministic
 - ***F***inite
 - ***A***utomaton
- DFAs are the simplest type of automaton that we will see in this course.

DFAs

- A DFA is defined relative to some alphabet Σ .
- For each state in the DFA, there must be *exactly one* transition defined for each symbol in Σ .
 - This is the “deterministic” part of DFA.
- There is a unique start state.
- There are zero or more accepting states.

How many of these are valid DFAs over $\{0, 1\}$?

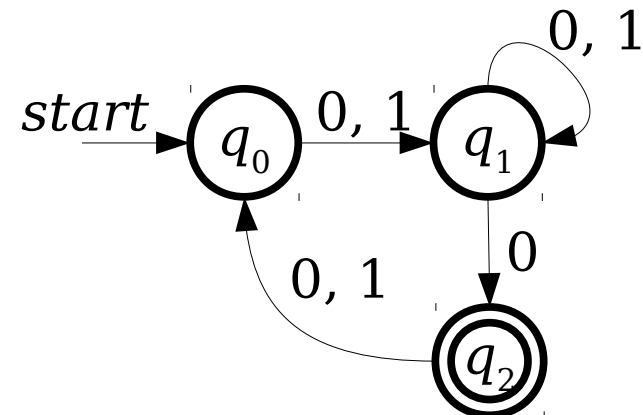
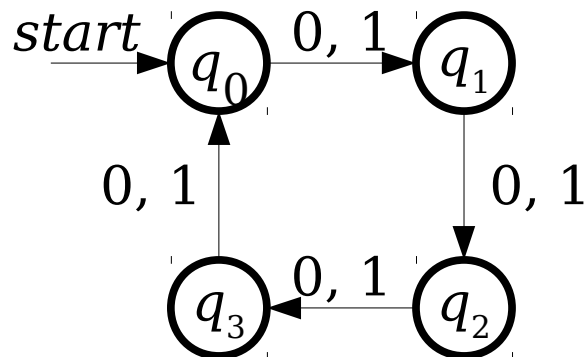
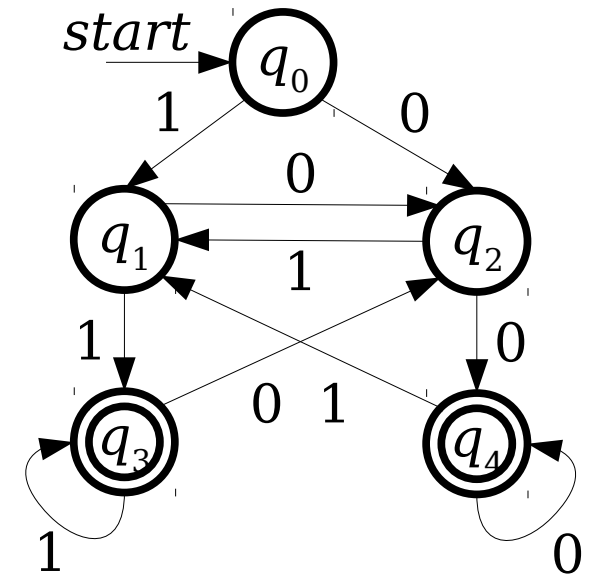
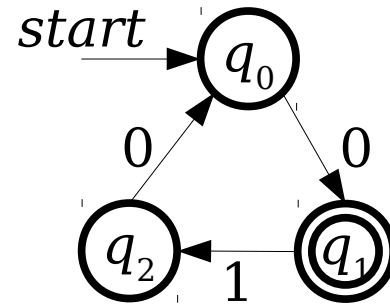
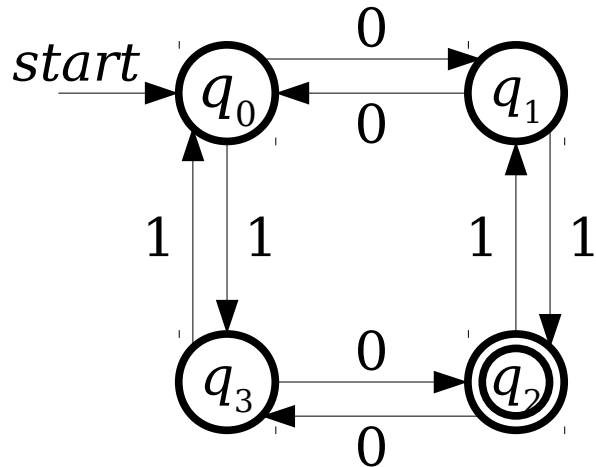

Answer at PollEv.com/cs103 or
text **CS103** to **22333** once to join, then a **number**.

Is this a DFA?

Designing DFAs

- At each point in its execution, the DFA can only remember what state it is in.
- ***DFA Design Tip:*** Build each state to correspond to some piece of information you need to remember.
 - Each state acts as a “memento” of what you're supposed to do next.
 - Only finitely many different states means only finitely many different things the machine can remember.

Recognizing Languages with DFAs

$L = \{ w \in \{\mathbf{a}, \mathbf{b}\}^* \mid \text{the number of } \mathbf{b}\text{'s in } w \text{ is congruent to two modulo three} \}$

Recognizing Languages with DFAs

$L = \{ w \in \{\mathbf{a}, \mathbf{b}\}^* \mid \text{the number of } \mathbf{b}\text{'s in } w \text{ is congruent to two modulo three} \}$

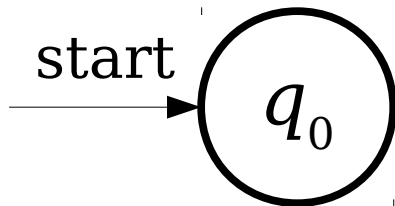

Recognizing Languages with DFAs

$L = \{ w \in \{\mathbf{a}, \mathbf{b}\}^* \mid \text{the number of } \mathbf{b}\text{'s in } w \text{ is congruent to two modulo three} \}$

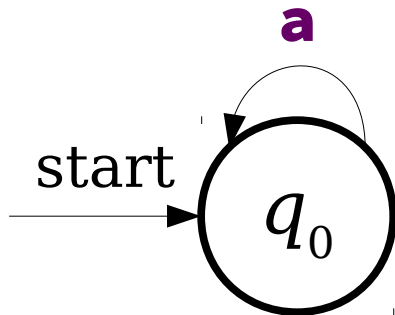

Recognizing Languages with DFAs

$L = \{ w \in \{\mathbf{a}, \mathbf{b}\}^* \mid \text{the number of } \mathbf{b}\text{'s in } w \text{ is congruent to two modulo three} \}$

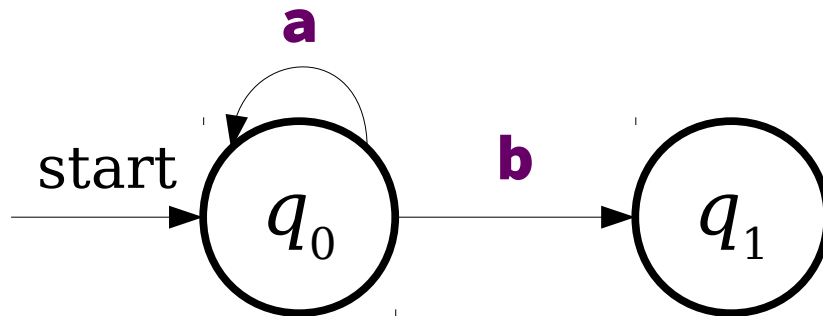

Recognizing Languages with DFAs

$L = \{ w \in \{\mathbf{a}, \mathbf{b}\}^* \mid \text{the number of } \mathbf{b}\text{'s in } w \text{ is congruent to two modulo three} \}$

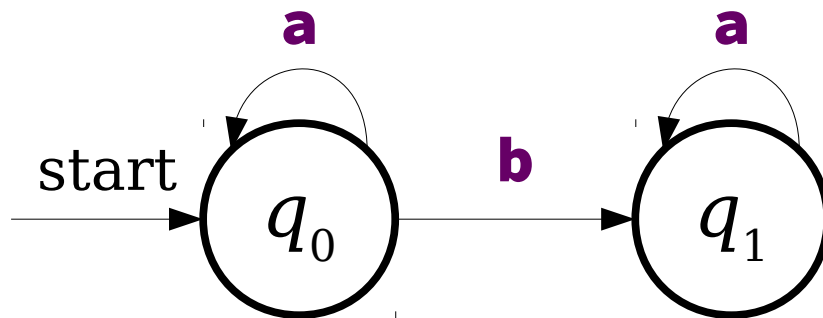

Recognizing Languages with DFAs

$L = \{ w \in \{\mathbf{a}, \mathbf{b}\}^* \mid \text{the number of } \mathbf{b}\text{'s in } w \text{ is congruent to two modulo three} \}$

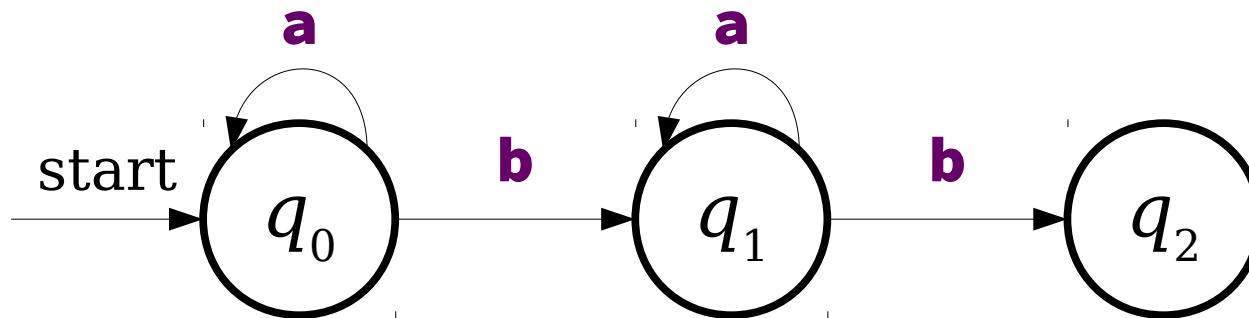

Recognizing Languages with DFAs

$L = \{ w \in \{\mathbf{a}, \mathbf{b}\}^* \mid \text{the number of } \mathbf{b}\text{'s in } w \text{ is congruent to two modulo three} \}$

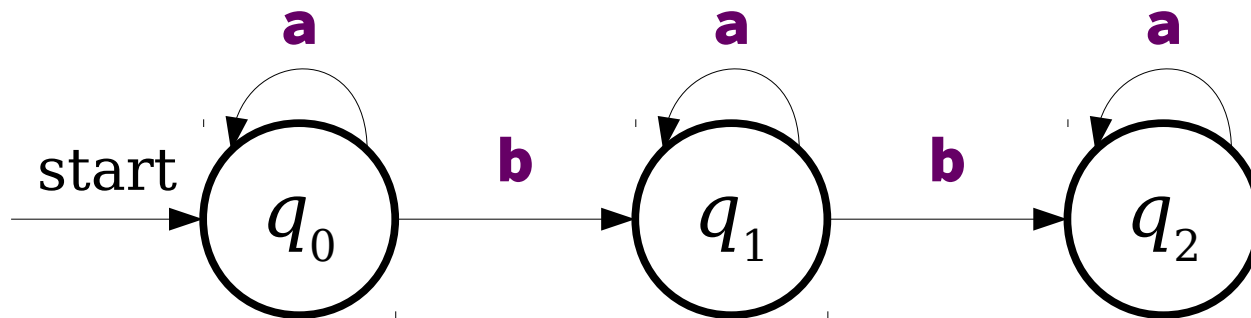

Recognizing Languages with DFAs

$L = \{ w \in \{\mathbf{a}, \mathbf{b}\}^* \mid \text{the number of } \mathbf{b}\text{'s in } w \text{ is congruent to two modulo three} \}$

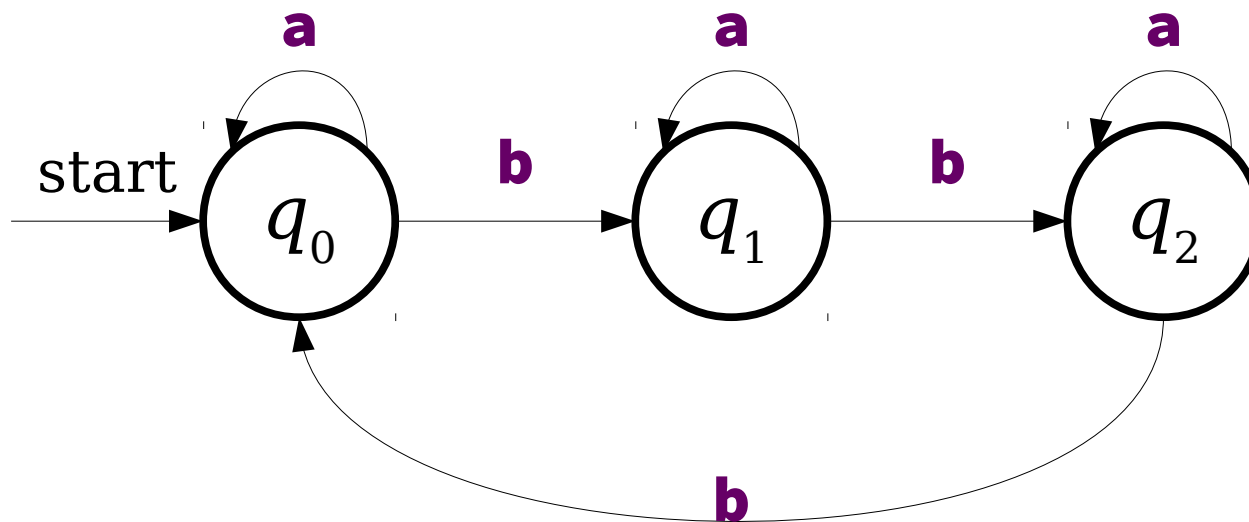

Recognizing Languages with DFAs

$L = \{ w \in \{\mathbf{a}, \mathbf{b}\}^* \mid \text{the number of } \mathbf{b}\text{'s in } w \text{ is congruent to two modulo three} \}$

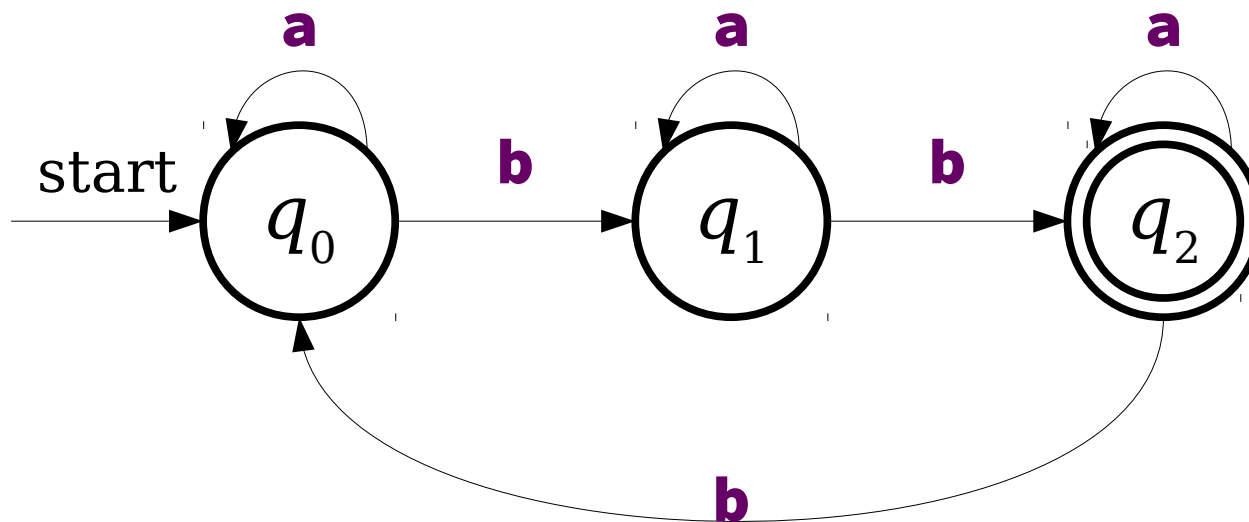

Recognizing Languages with DFAs

$L = \{ w \in \{\mathbf{a}, \mathbf{b}\}^* \mid \text{the number of } \mathbf{b}\text{'s in } w \text{ is congruent to two modulo three} \}$

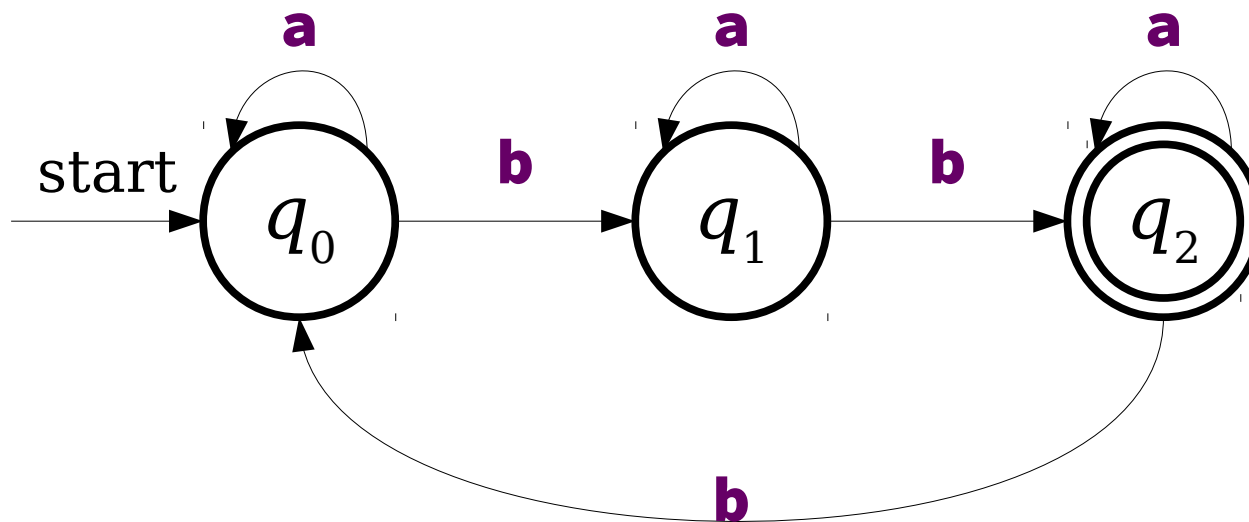

Each state remembers the remainder of the number of **b**s seen so far modulo three.

Recognizing Languages with DFAs

$L = \{ w \in \{a, b\}^* \mid w \text{ contains } aa \text{ as a substring} \}$

Recognizing Languages with DFAs

$L = \{ w \in \{a, b\}^* \mid w \text{ contains } aa \text{ as a substring} \}$

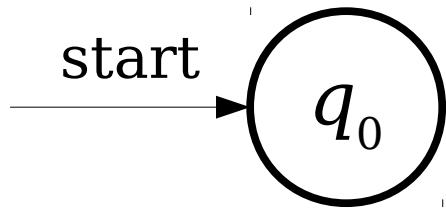

Recognizing Languages with DFAs

$L = \{ w \in \{a, b\}^* \mid w \text{ contains } aa \text{ as a substring} \}$

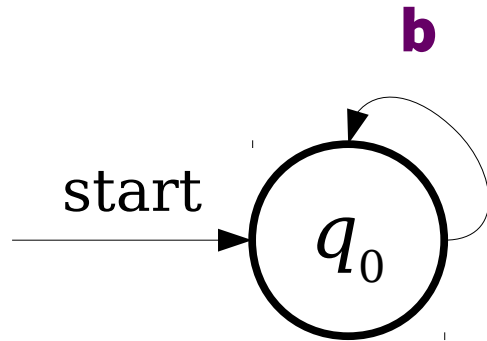

Recognizing Languages with DFAs

$L = \{ w \in \{a, b\}^* \mid w \text{ contains } aa \text{ as a substring} \}$

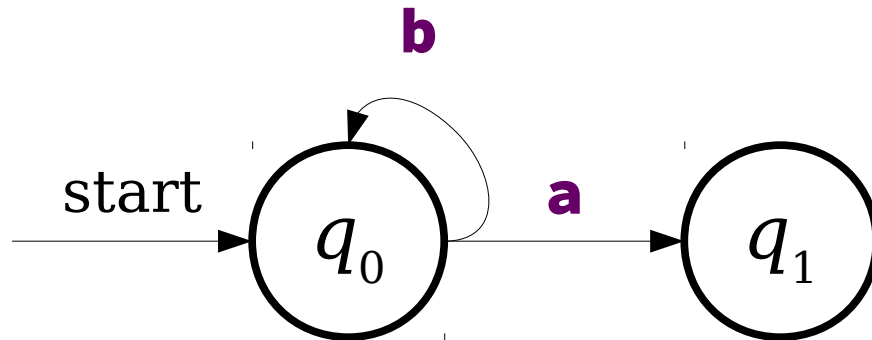

Recognizing Languages with DFAs

$L = \{ w \in \{a, b\}^* \mid w \text{ contains } aa \text{ as a substring} \}$

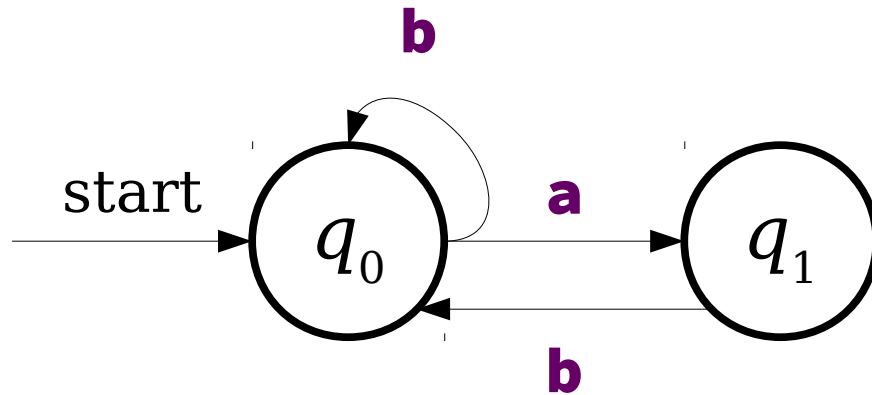

Recognizing Languages with DFAs

$L = \{ w \in \{a, b\}^* \mid w \text{ contains } aa \text{ as a substring} \}$

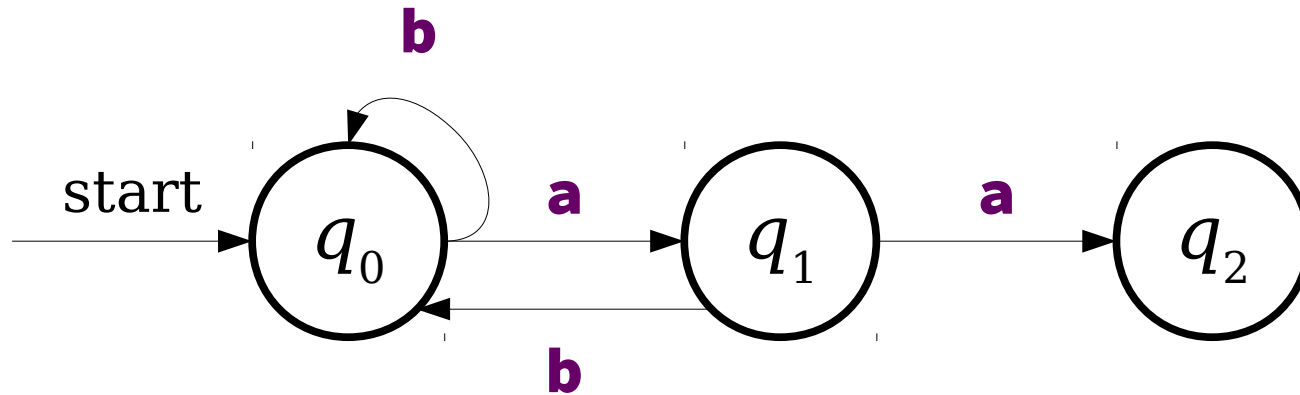

Recognizing Languages with DFAs

$L = \{ w \in \{a, b\}^* \mid w \text{ contains } aa \text{ as a substring} \}$

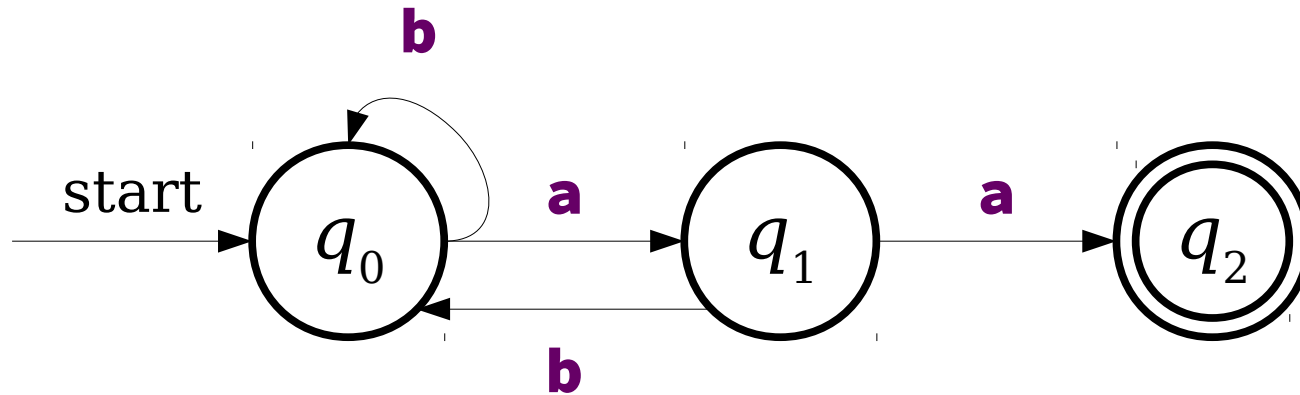

Recognizing Languages with DFAs

$L = \{ w \in \{a, b\}^* \mid w \text{ contains } aa \text{ as a substring} \}$

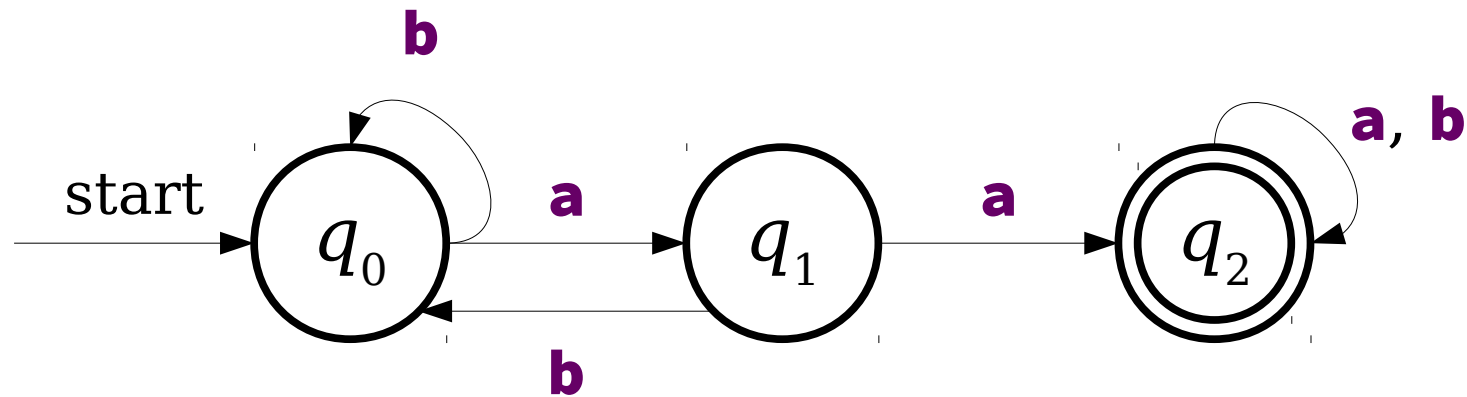

Recognizing Languages with DFAs

$L = \{ w \in \{a, b\}^* \mid w \text{ contains } aa \text{ as a substring} \}$

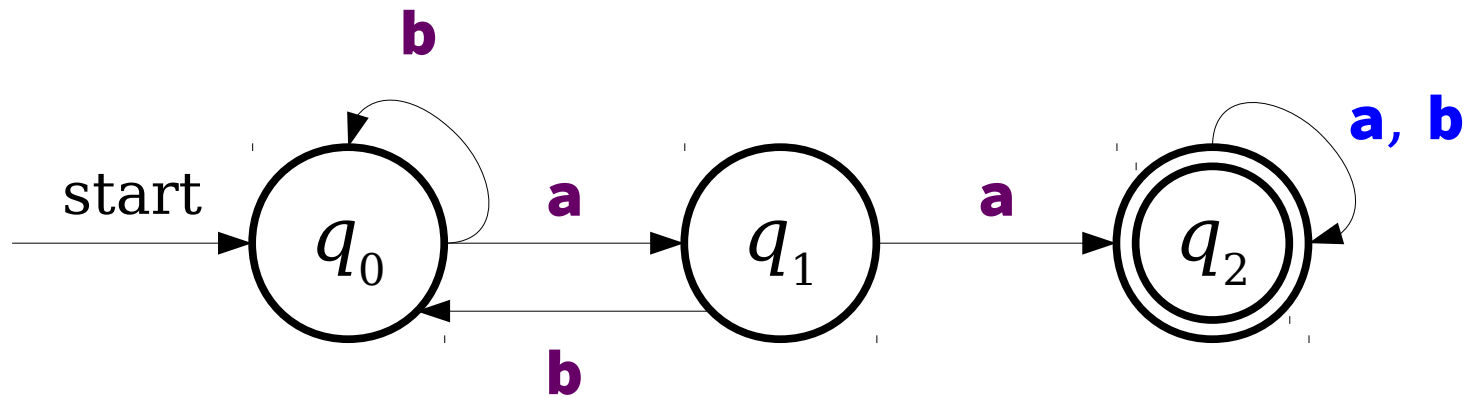

Recognizing Languages with DFAs

$L = \{ w \in \{a, b\}^* \mid w \text{ contains } aa \text{ as a substring} \}$

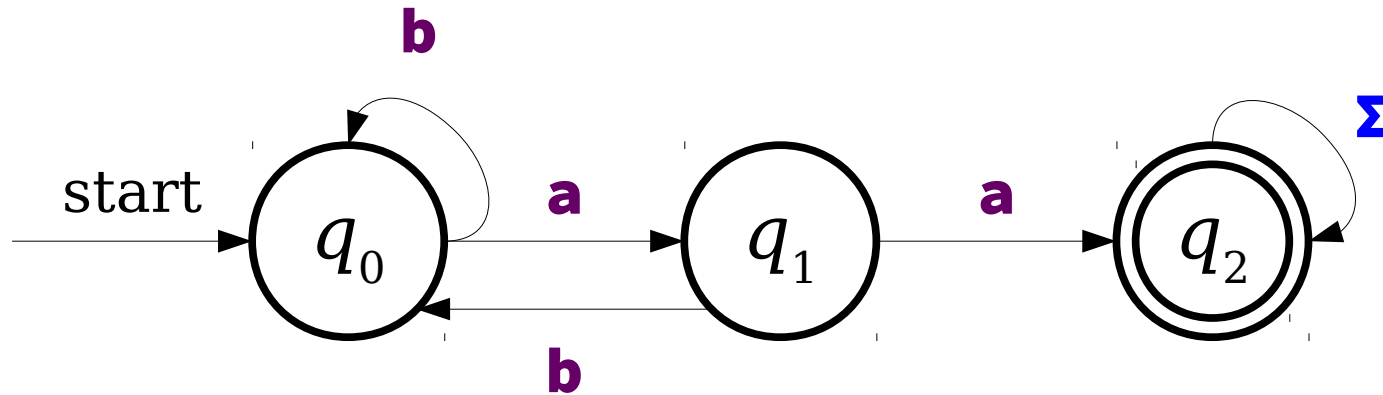

Recognizing Languages with DFAs

$L = \{ w \in \{a, b\}^* \mid w \text{ contains } aa \text{ as a substring} \}$

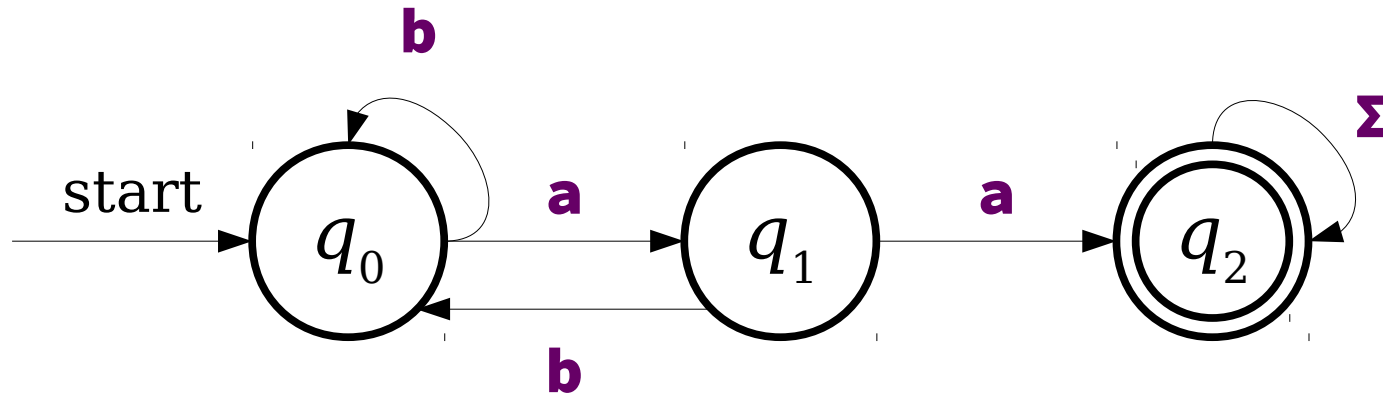

More Elaborate DFAs

$L = \{ w \in \{a, *, /\}^* \mid w \text{ represents a C-style comment} \}$

Let's have the **a** symbol be a placeholder for "some character that isn't a star or slash."

Try designing a DFA for comments! Here's some test cases to help you check your work:

Accepted:

/*a*/
//**
/*/**
/*aaa*aaa*/
/*a/a*/

Rejected:

/**
//a/**a*/**
aaa//aa**
/*/
/a/**
//aaaa

More Elaborate DFAs

$L = \{ w \in \{ \mathbf{a}, \mathbf{*}, \mathbf{/} \}^* \mid w \text{ represents a C-style comment} \}$

